

Changing Stylus Systems Made Easy.

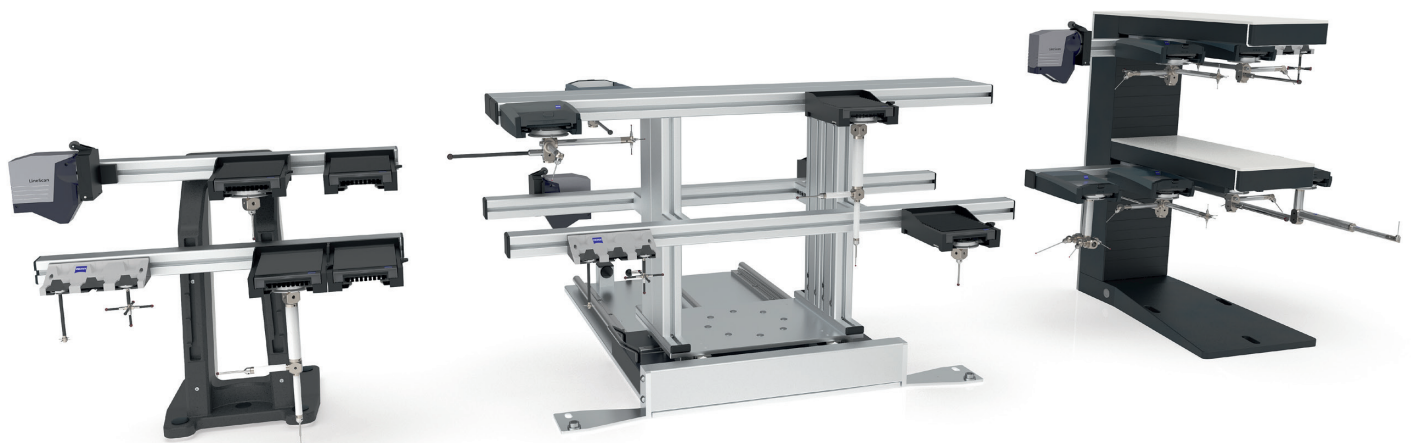

ZEISS Multi-Sensor-Racks

ZEISS

zeiss.com/metrology

Seeing beyond

Automatic Changing of Stylus Systems

Increase both capacity and productivity

Complex measurements often require the use of several stylus systems. However, manually changing and calibrating the storage locations is an inefficient process.

The Multi-Sensor-Rack (MSR) is a modular storage concept from ZEISS that enables automatic component changes for interruption-free measurements. This saves time and boosts efficiency, particularly for complex measurements featuring multiple stylus changes in a single workflow.

As an innovation leader with over 100 years of experience in the field, ZEISS provides a trio of customizable multi-rack solutions for greater productivity in every application.

Accessories for all MSR models

- Probe Socket VAST/MT, VAST XTR, for RDS mounting plate, ST3/ST
- Stylus deposit magazine XXT, 3-fold



A Reliable Storage Solution

ZEISS Multi-Sensor-Rack 2.0

The Multi-Sensor-Rack automation concept is based on integration: Not only is the MSR integrated into the measuring volume of the CMM itself, the probe racks are even integrated into the software. This setup is therefore able to remember where each stylus system is placed, further increasing the efficiency of measurements.

Featuring small interference contours and wide-ranging configuration options, ZEISS Multi-Sensor-Rack MSR 2.0 maximizes the output that can be achieved with a given stylus or sensor mount.



Optimizing Storage Opportunities

Since the new ZEISS MSR 2.0 can be expanded with two storage bars, it provides more space for probe sockets than its predecessor. The sensor rack also offers an efficient means of upgrading existing CMMs and reducing their downtime. Anyone currently operating its predecessor model ZEISS MSR mini can take advantage of easy and cost-effective retrofit options to enjoy the advantages.

Advantages and Characteristics

- Entry-level model with 20 storage options
- Alternative to self-assembly solutions
- More storage options than ZEISS MSR mini for the same price
- Modular system is highly versatile, ensuring the right solution for every requirement
- Optimized connection and customized design
- Adjustable for easy handling of additional components
- Can be extended with a third storage level (special adapter is required)

Column

Version	MSR 2.0 600	MSR 2.0 800
Z measuring range	> 600 mm	> 800 mm
Storage bars	Up to 2	Up to 2
Working range H1	480 mm	680 mm
Working range H2 ¹⁾	335 / 290 / 245 / 200 mm	535 / 500 / 455 / 400 / 355 / 315 / 270 / 225 mm
Weight	7.7 kg	11.2 kg
Machine	ZEISS CONTURA / ZEISS SPECTRUM / ZEISS PRISMO	ZEISS CONTURA / ZEISS PRISMO
Material number	626100-9300-600	626100-9300-800

1) Work area H2 can be variably positioned.

Note: Storage bars and holders are not included in the scope of delivery.

Storage bar

	Width	For measuring volume	Max. amount of sockets	Material number
B590	590 mm	≥ 500 mm	4	626100-9300-001
B790	790 mm	≥ 700 mm	6	626100-9300-002
B990	990 mm	≥ 900 mm	8	626100-9300-003
B1090	1090 mm	≥ 1000 mm	9	626100-9300-004
B1290	1290 mm	≥ 1200 mm	10	626100-9300-005

Note: Number of sockets relative to MT-VAST socket; possible sockets: VAST/MT, VAST XTR, for RDS mounting plate, ST3/ST, XXT.

Note: Storage bars and sockets are not included in scope of delivery of MSR 2.0; these must be ordered separately depending on measuring volume.

Use the full potential of your CMM:
probes.zeiss.com



Twice the Storage

ZEISS Multi-Sensor-Rack Duplex

If you need to measure a complex part requiring a large number of stylus systems, ZEISS Multi-Sensor-Rack Duplex is the ideal choice. Featuring up to 58 storage options, it offers twice the capacity of the standard version.

The ZEISS MSR Duplex is manually pushed out of the measuring volume and rotated 180 degrees. It is then fixed in the measuring volume.

This innovative approach saves time and boosts efficiency during the measurement process. Operators can even install an additional third level for even more storage options.

More Capacity on Your CMM

Two back-to-back rotatable probe racks provide twice as much room as a standard rack for your stylus systems. This enables you to measure many more different parts in less time. More stylus systems are calibrated and ready for use.

The Right Solution for Multisensor Measuring Machines

Probe sockets for VAST, RDS, and XXT can be arranged as needed on both sides of the probe rack. ZEISS MSR Duplex also provides sufficient room for probes.

Advantages and Characteristics

- With 58 storage options, ZEISS MSR Duplex doubles the number of storage options
- Enables you to measure many different parts in less time
- Modular system is highly versatile, ensuring the right solution for every requirement
- Easy handling
- Can be extended with a third storage level
- Manual 180° rotation



Multi-Sensor-Rack (MSR) Duplex

	Material number	Width	Height	Turning diameter	Levels	Magazine spaces MT VAST	Additional level
MSR Duplex X=700	626100-9304-000	810 mm	480 mm	935 mm	2	24	-
MSR duplex X=900	626100-9314-000	1010 mm	580 mm	1110 mm	2	32	X700 +6 magazine spaces MT VAST
MSR Duplex X=1200	626100-9324-000	1260 mm	880 mm	1346 mm	2	40	X900 +8 magazine spaces MT VAST



Use the full potential of your CMM:
probes.zeiss.com



More Measuring Volume

ZEISS ProMax E

Uniquely located outside of the CMM measuring volume, ZEISS ProMax E simply moves forward automatically when needed. After switching to the required stylus or sensor, it then exits the measuring volume to guarantee collision-free operation. It also ensures safe handling of stylus systems through proper pick-up out of the probe sockets.

As the measuring volume does not have to accommodate the probe rack, it enables maximum flexibility for the parts and for the travel path of the measuring head.

Easy Retrofit

ZEISS Pro Max E ensures high flexibility and safe handling of stylus systems due to its inherent design characteristics. It enables highly flexible use of the space as it is located outside the CMM measuring volume. This allows the user to take advantage of the full CMM measuring volume, therefore making greater use of the available capacity and improving efficiency.

Advantages and Characteristics

- Extension for small footprint and therefore more available measuring range
- Up to 27 MT/VAST or XTR stylus systems available
- More safety: improved repeatability via electric drive
- Can be combined with every ZEISS probe socket
- Modular system is highly versatile, ensuring the right solution for every requirement
- Can be extended with a third storage level
- Requires probe sockets and ProMax E package (not included) plus firmware version ≥ 40

ZEISS ProMax E

Machine	Size (X/Y/Z)	Material number	Storage capacity	Extension modules
Retrofit:	ProMax E PRISMO 7/Y/5	626100-9905-011	6	1
ZEISS PRISMO /	ProMax E PRISMO 7/Y/7	626100-9906-011	6	2
ACCURA 1 C99N	ProMax E PRISMO 9/Y/7	626100-9907-011	8	2
Retrofit:	ProMax E CONTURA 7/Y/6	626100-9802-011	6	1
ZEISS CONTURA	ProMax E CONTURA 9/Y/6	626100-9803-011	8	1
G2 C99L/L2	ProMax E CONTURA 9/Y/8	626100-9805-011	8	2
New system:	ProMax E CONTURA 10/Y/6	626100-9804-011	9	1
ZEISS CONTURA 6206 C99m				
Extension: module and storage bar	Module 300 mm	626100-8810-000		
	Storage bar ProMax E X=700 mm	626100-8812-000		
	Storage bar ProMax E X=900 mm	626100-8813-000		
	Storage bar ProMax E X=1000 mm	626100-8814-000		

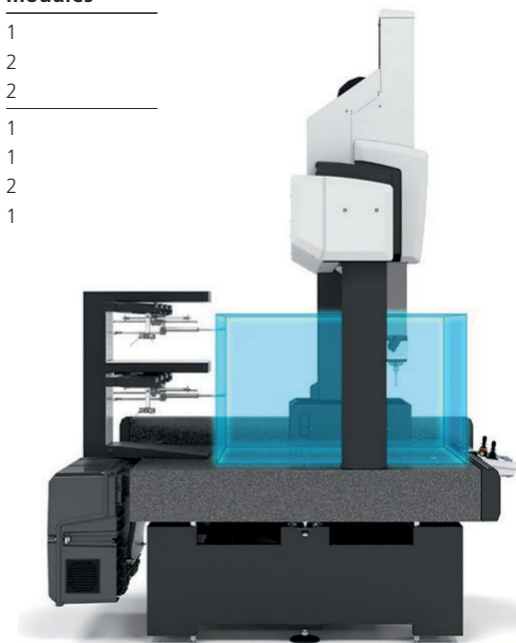

Use the full potential of your CMM:
probes.zeiss.com



Additional Solutions in the ZEISS portfolio

MSR for Optical CMM

ZEISS Multi-Sensor-Rack serves as an efficient and flexible probe rack for ZEISS O-INSPECT. Featuring sufficient capacity for up to 3 ZEISS VAST XXT probe plates, it is fixed in the CMM measuring volume by means of a magnetic holder. Supporting automated probe changing and full usage of the ZEISS O-INSPECT measuring volume, it includes an MCA signal converter and cabling. The minimum required clearance from the wall is only 500 mm.

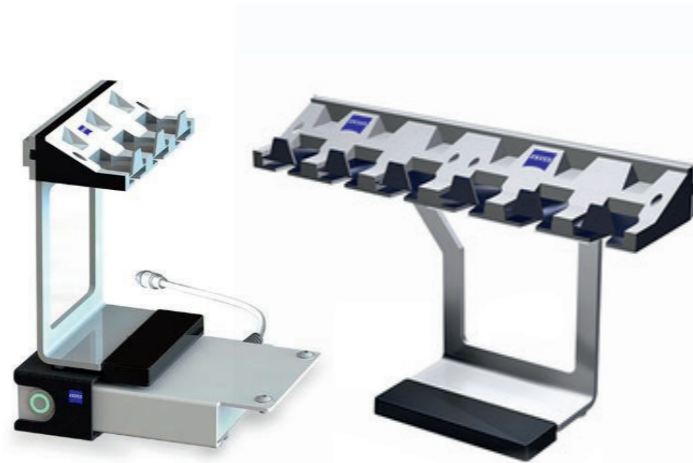

Additional Levels

Operators looking for enhanced functionality can optionally upgrade their ZEISS MSR 2.0 and ZEISS MSR Duplex models with an additional level. This upgrade ensures extra storage space for probe sockets. By upgrading their setup with an additional level, operators can further optimize their workflow and deliver a fresh boost to their productivity.



Stylus Systems

ZEISS styli are available in a number of different versions, with operators free to choose from a large portfolio of standard styli for M2, M3, M3XXT, and M5 threads. The different stylus tips are made of different materials and ZEISS provides a variety of shaft designs for these styli. Non-threaded styli and special styli for form, contour and surface measurements complete the ZEISS range.

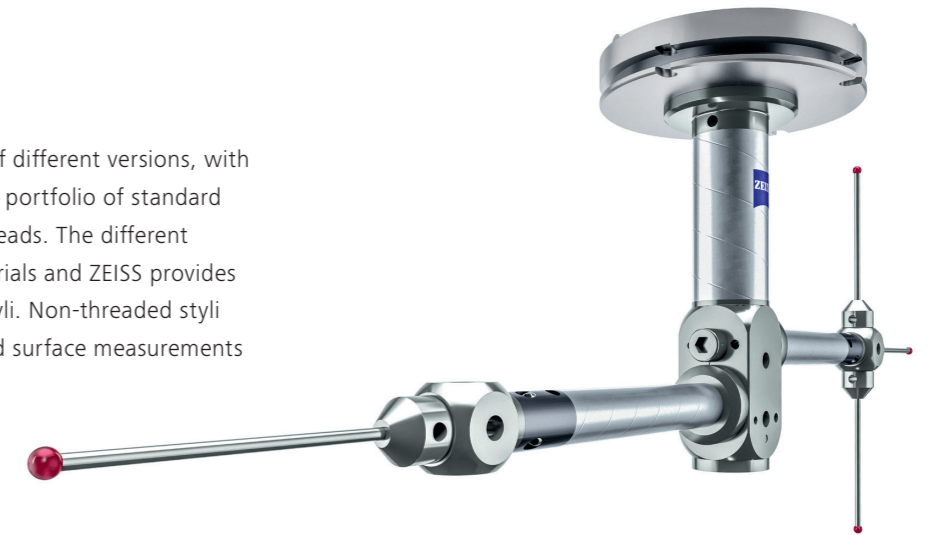

Probe Sockets

Probe sockets are quick and easy to install, providing storage for various probe systems. When more probe systems are needed for measurements, more probe sockets are required for automatic changing. Probe sockets can be arranged next to and above one another (offset on Y-axis), with the maximum number determined by the size of the machine and the probe systems. To prevent collisions, please check the available rack space before adding a new magazine. Only probe sockets that are inspected and approved by ZEISS are permitted.



Further information:
probes.zeiss.com



Further information:
probes.zeiss.com



Carl Zeiss IQS Deutschland GmbH

Carl-Zeiss-Straße 22
73447 Oberkochen

Vertrieb

Telefon: +49 7364 20 6337
E-Mail: sales.metrology.de@zeiss.com

Service

Telefon: +49 7364 20 6337
E-Mail: info.metrology.de@zeiss.com

www.zeiss.de/imt

Carl Zeiss Industrial Quality Solutions, LLC

6250 Sycamore Lane North
Maple Grove, MN 55369, USA

Phone: +1 800 327-9735
Fax: +1 763 533-0219
Email: info.metrology.us@zeiss.com

www.zeiss.com/metrology