

Boris Becker

Dan Dennett

George Smith

Pete Sampras

Boris Becker

Pete Sampras

(write winner's name above)

God

M i n d

D e s i g n

O r d e r

C h a o s

N o t h i n g

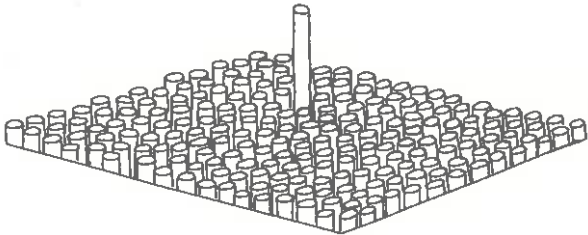

FIGURE 3.1

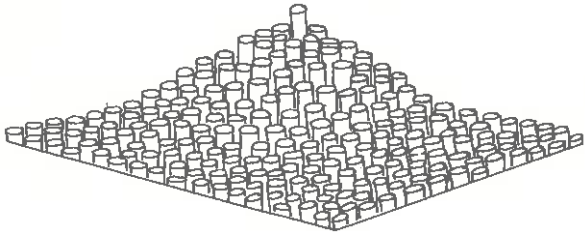

FIGURE 3.2

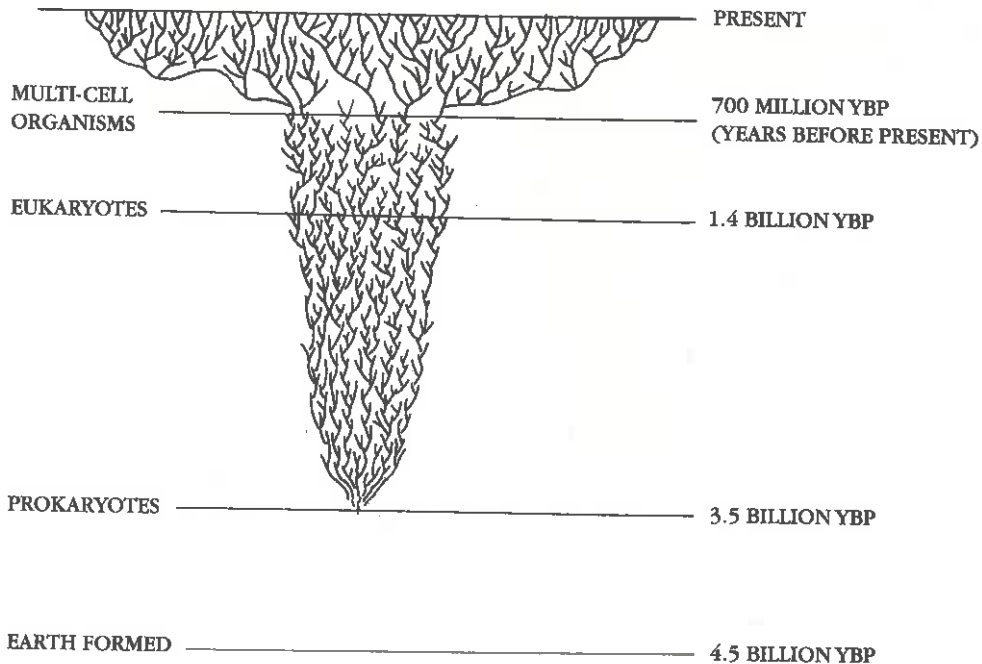

FIGURE 4.1

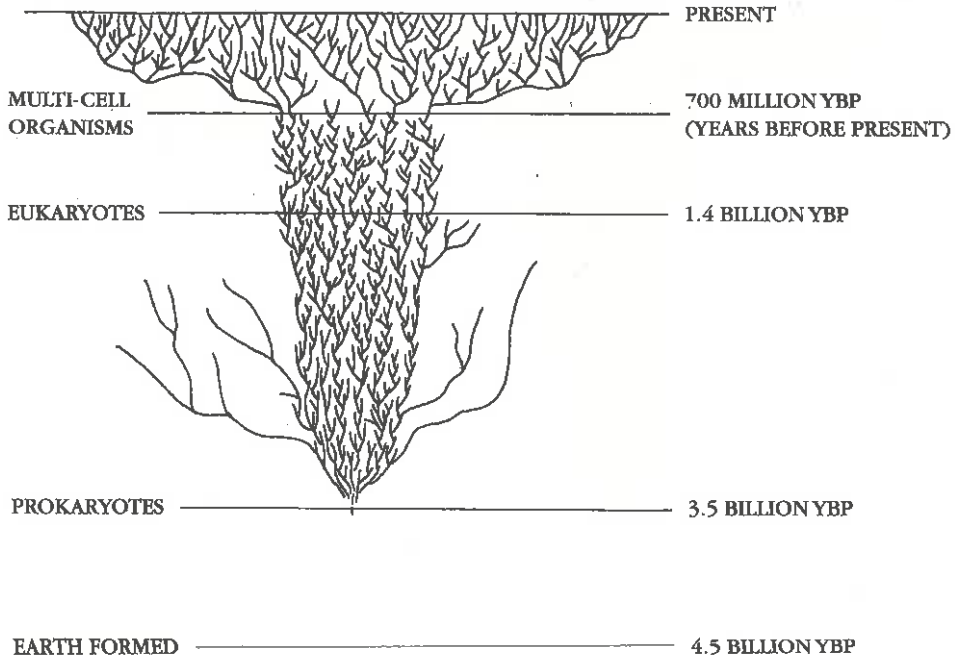

FIGURE 4.2

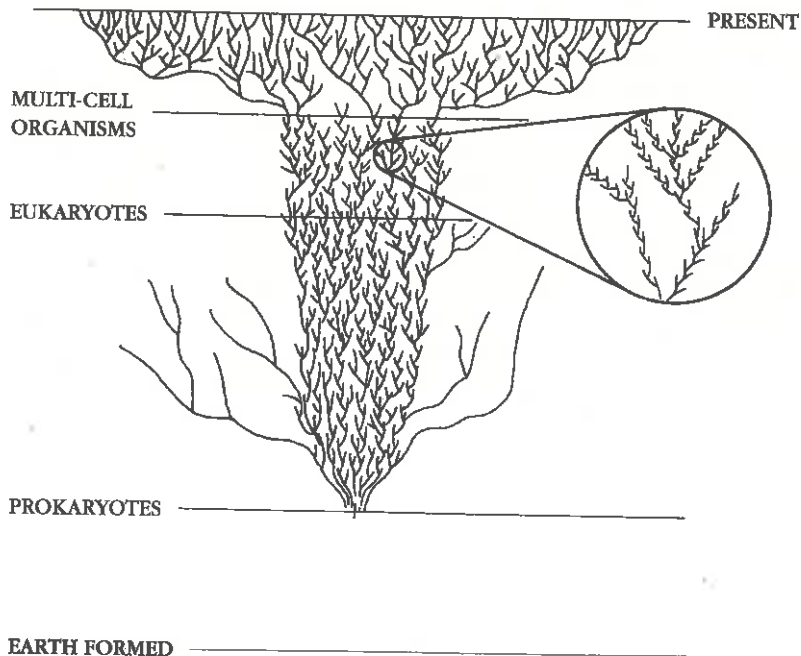

FIGURE 4.3

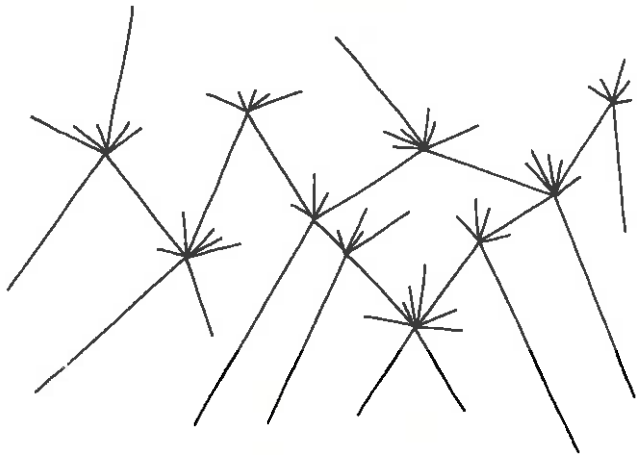

FIGURE 4.4

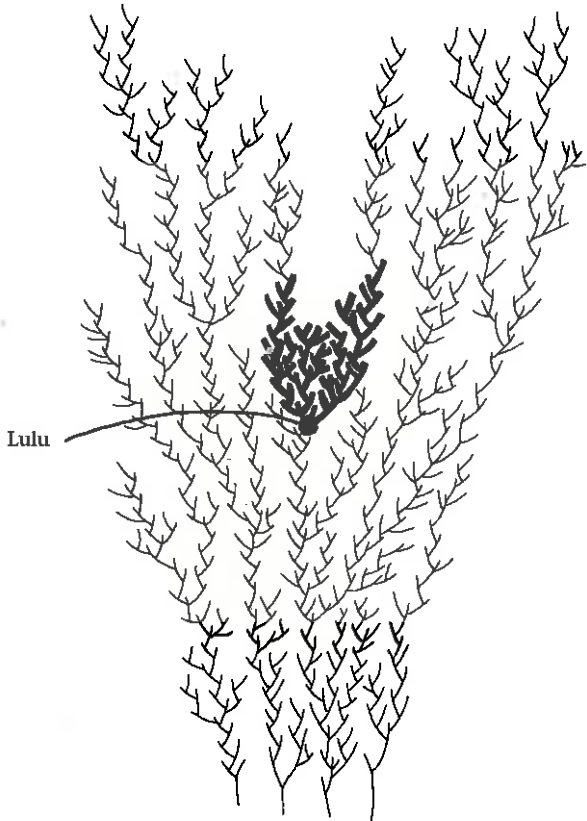

FIGURE 4.5

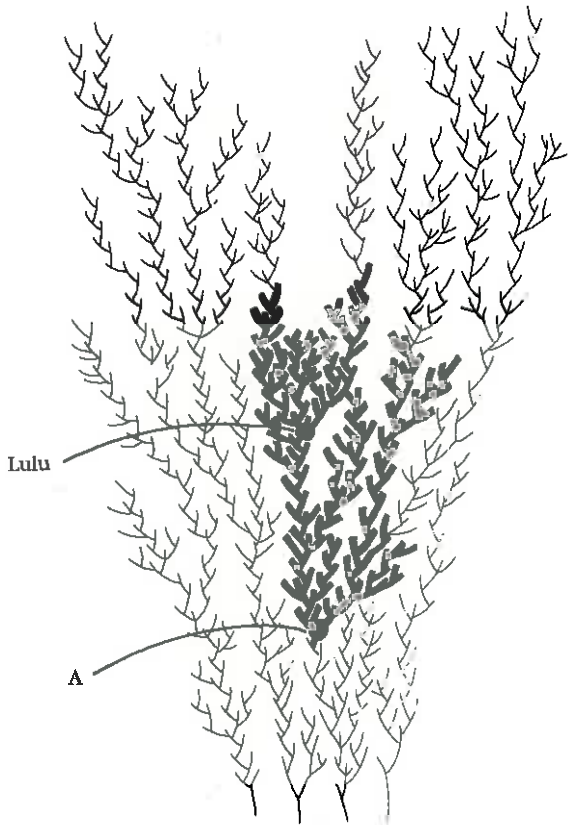

FIGURE 4.6

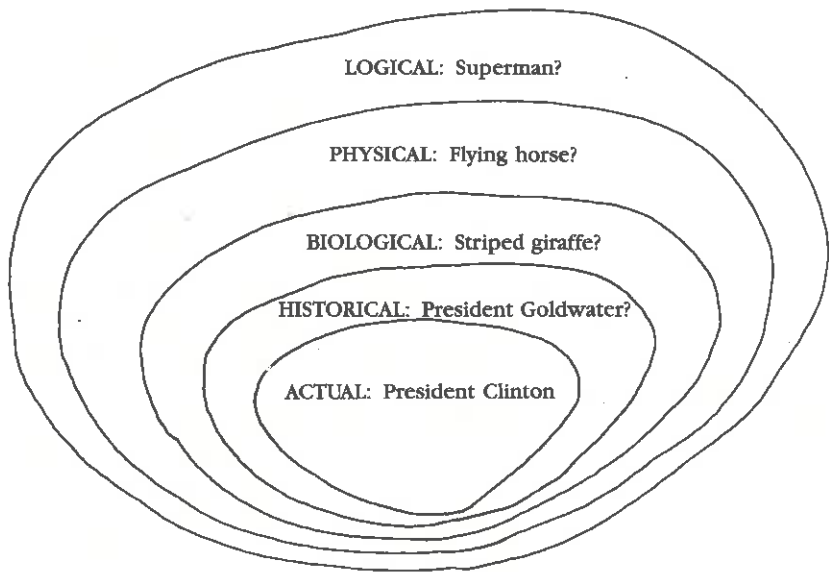

FIGURE 5.1

Freunde, Römer, Mitbürger, gebt mir Gehör!
Ich komme, Cäsars Leiche zu bestatten, nicht, ihn zu
loben.

FIGURE 6.1

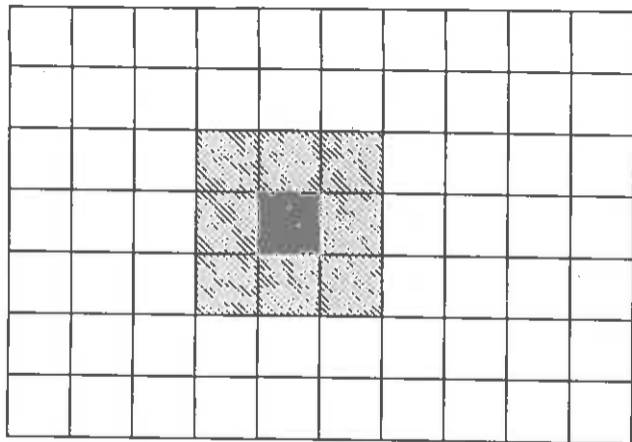

FIGURE 7.2

			A	B	C				
			D	E	F				
			G	H	I				

FIGURE 7.3

			A	B	C				
			D	E	F				
			G	H	I				

FIGURE 7.4

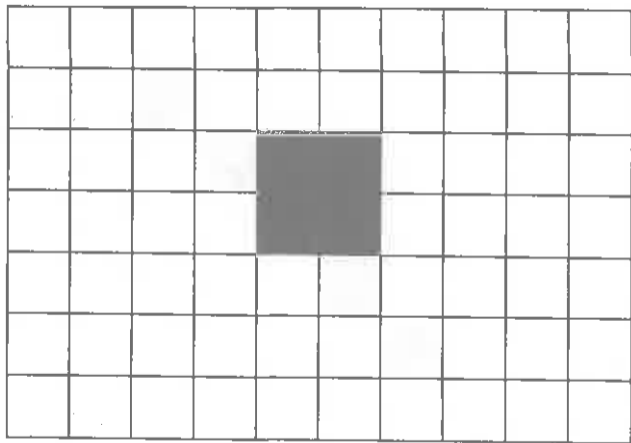

FIGURE 7.5

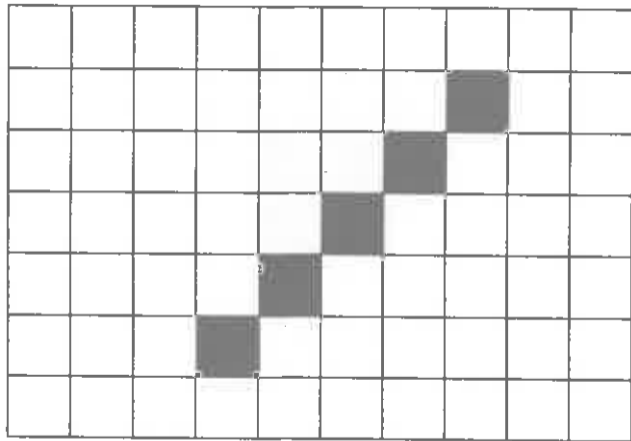
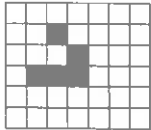
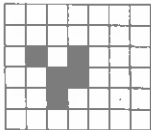

FIGURE 7.6



time 0



time 1

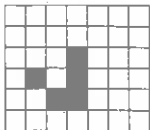

time 2

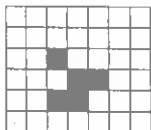

time 3

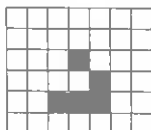

time 4

FIGURE 7.7

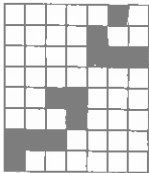

time 0

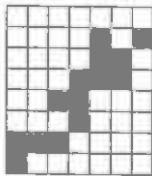

time 1

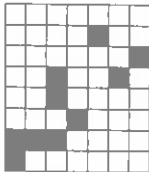

time 2

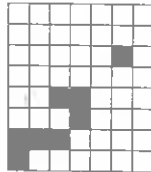

time 3

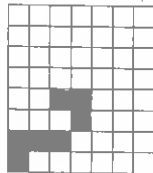

time 4

FIGURE 7.8

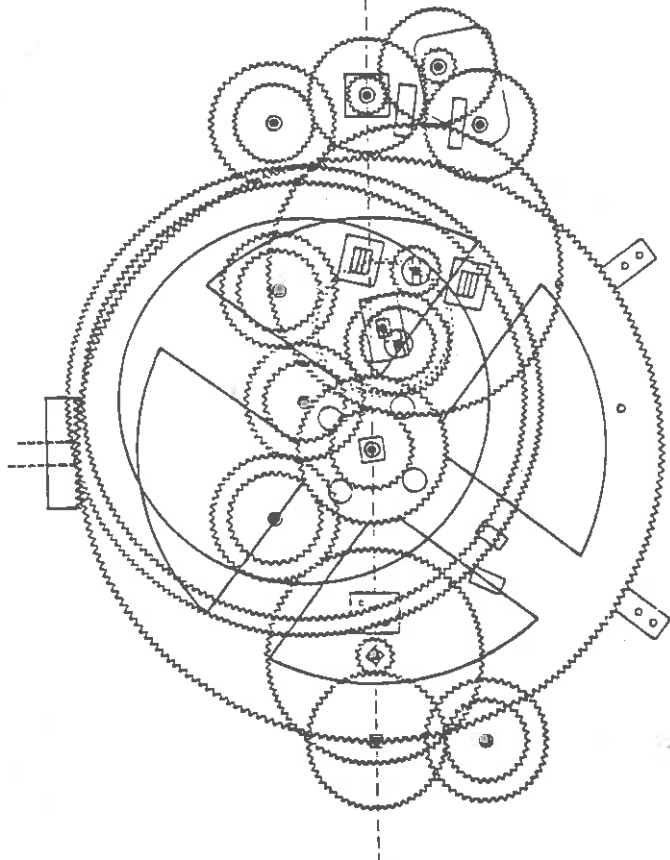
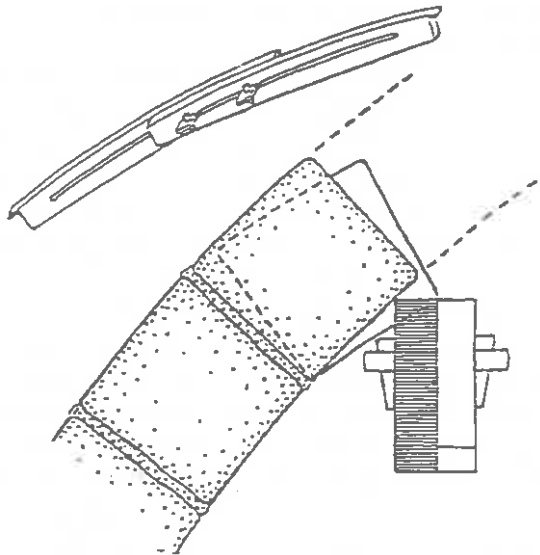

FIGURE 9.1.

Figure diagramming the wheel-work of the Antikythera mechanism by Derek de-Solla Price (Yale University).



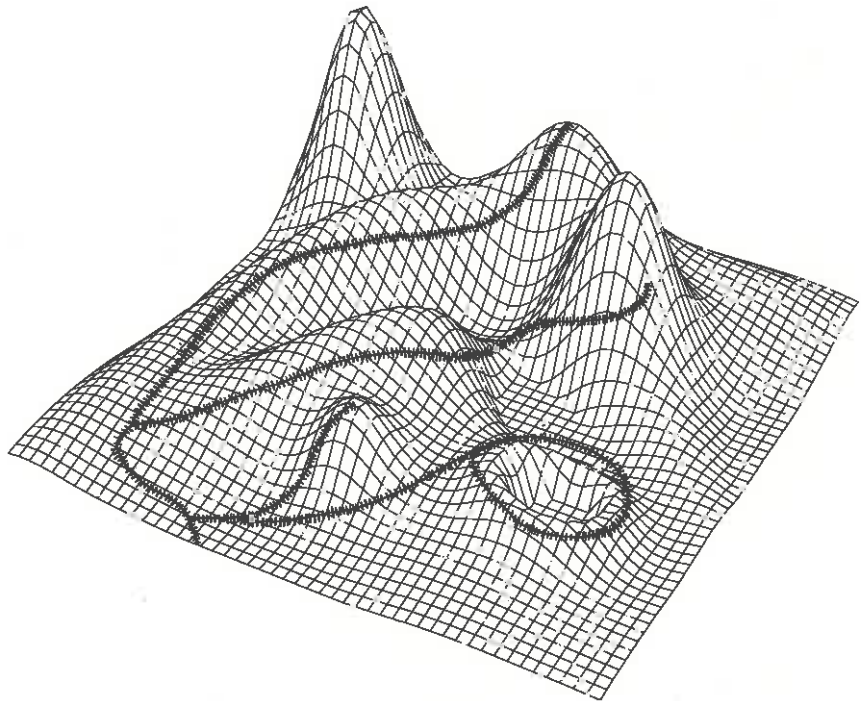

FIGURE 9.4

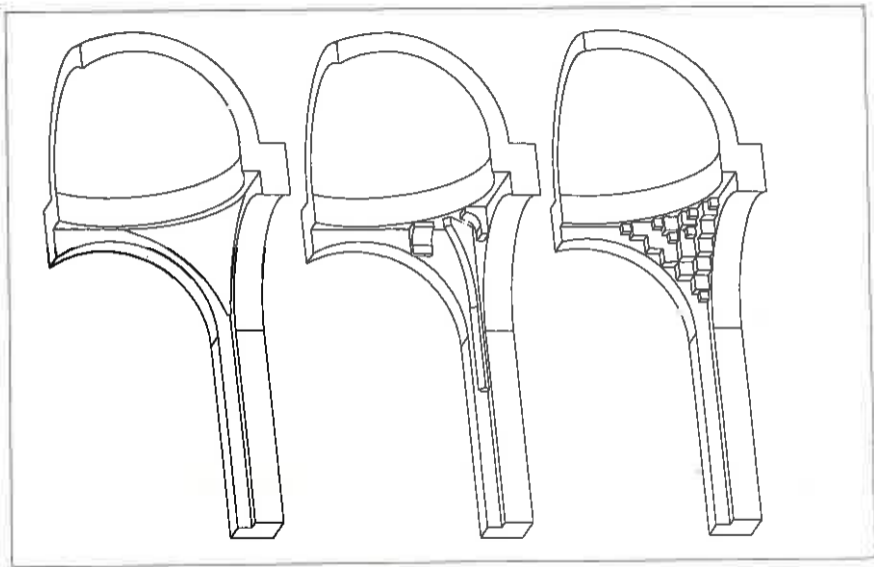

FIGURE 10.3

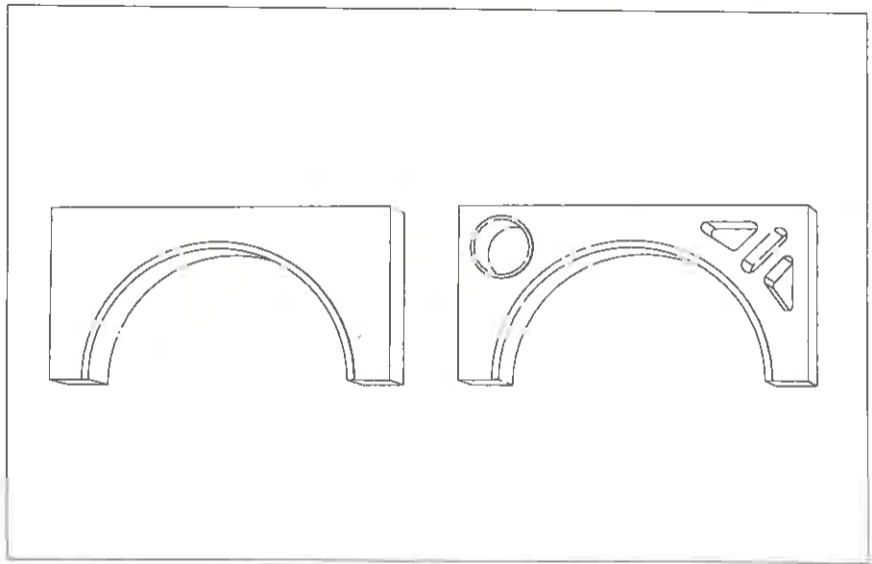
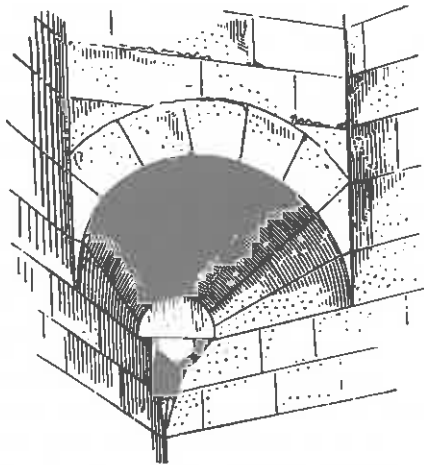

FIGURE 10.4



Squinch. A corbelling, usually a small arch or half-cornical niche, which is placed across the corners of a square bay in order to form an octagon suitable for carrying an octagonal cloister-vault or a dome. [Krautheimer 1981.]

FIGURE 10.5

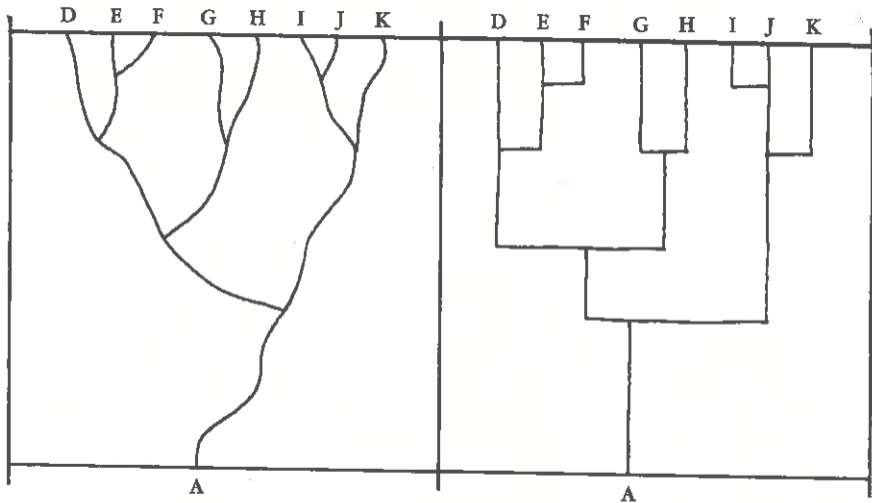

FIGURE 10.6

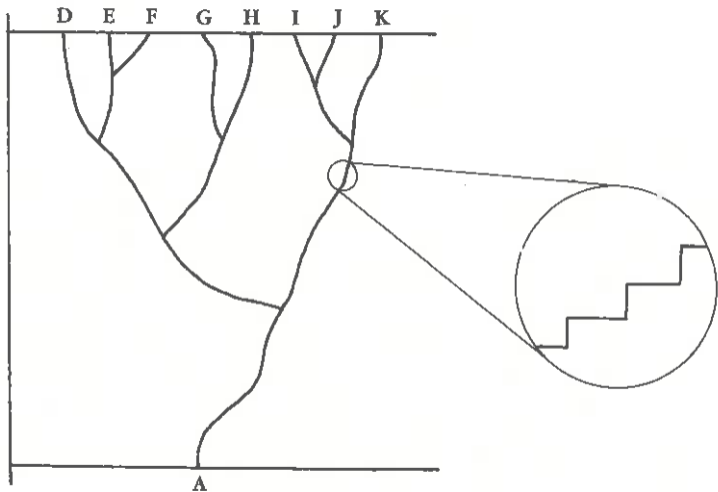

FIGURE 10.7

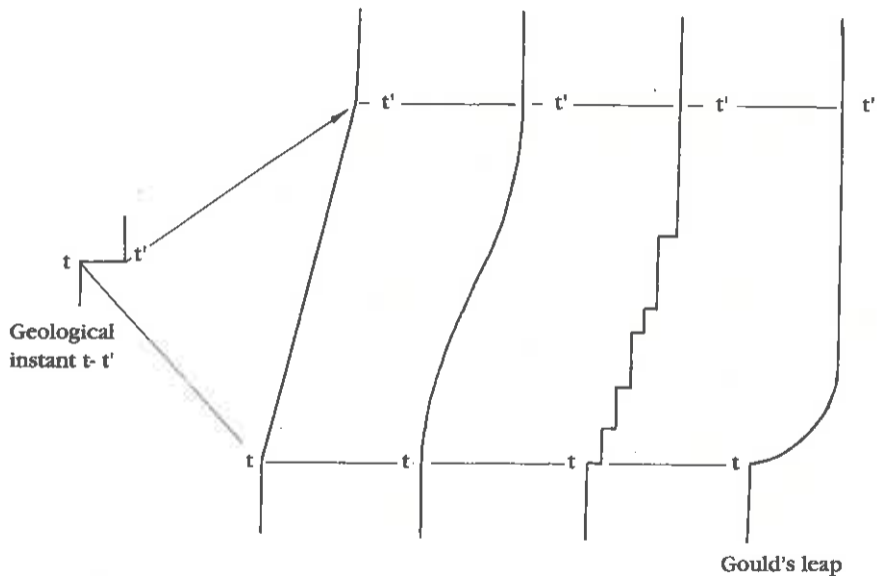
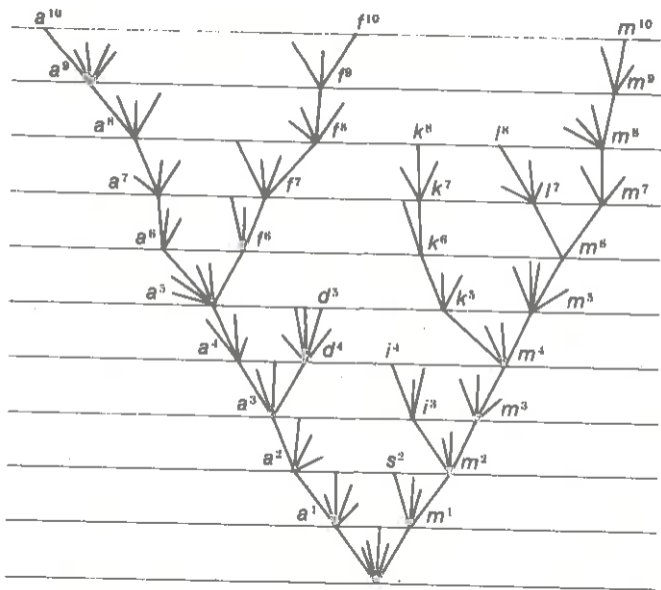

FIGURE 10.8



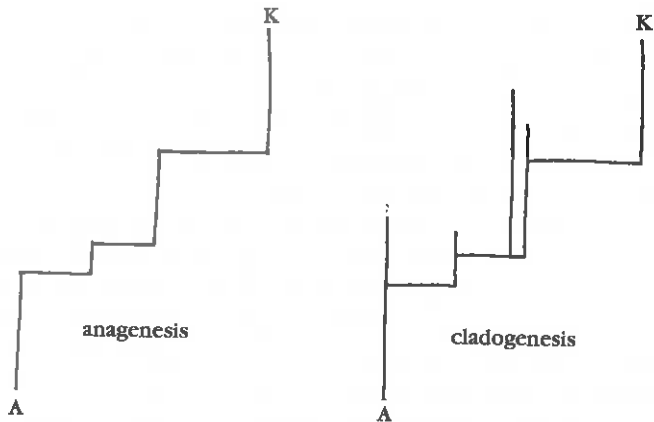

FIGURE 10.10

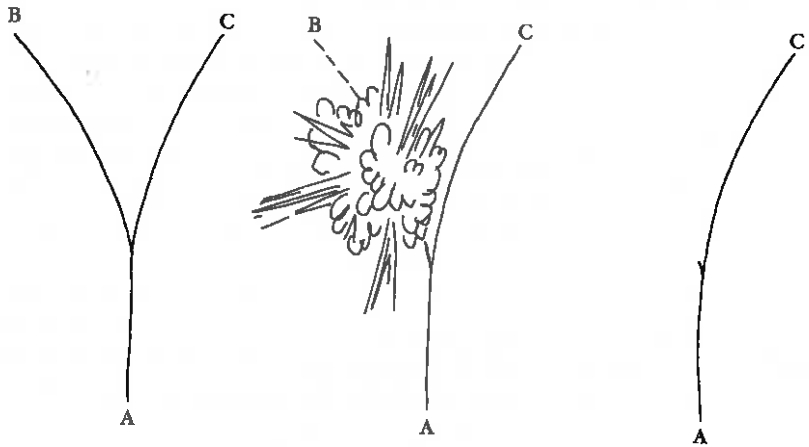
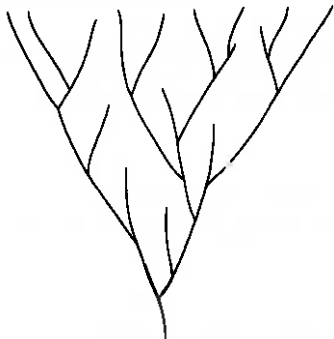
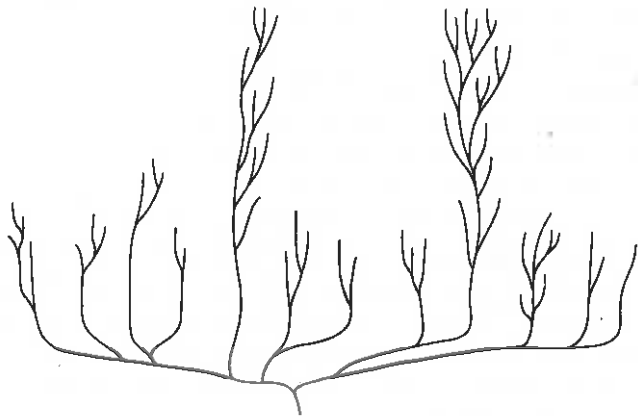

FIGURE 10.11

The Cone of Increasing Diversity



Decimation and Diversification



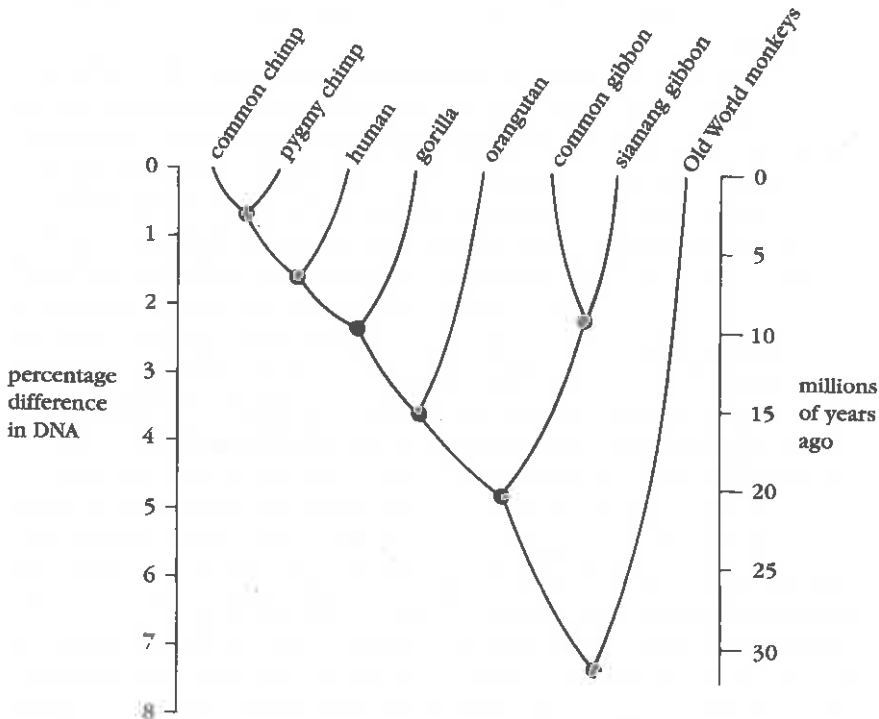

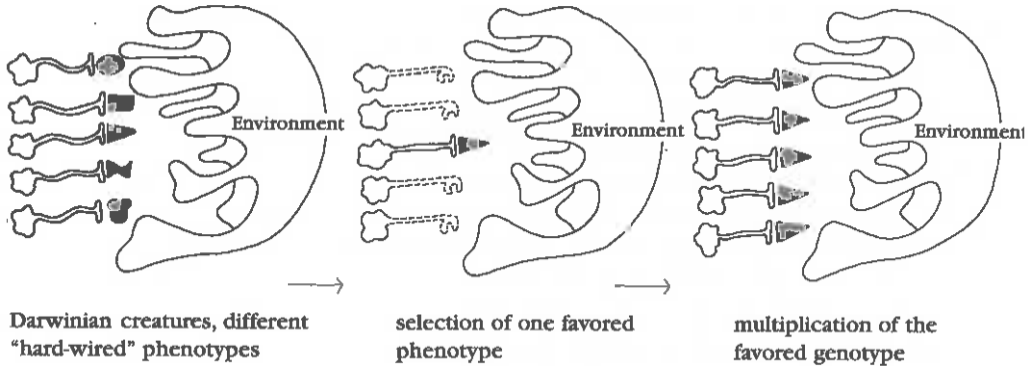
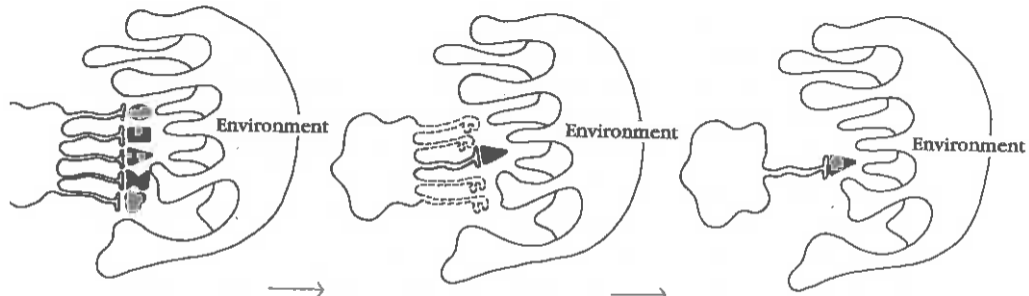

FIGURE 13.1



kinnerian creature "blindly"
tries different responses ...

... until one is selected by
"reinforcement."

Next time, the creature's first
choice will be the reinforced response.

FIGURE 13.2

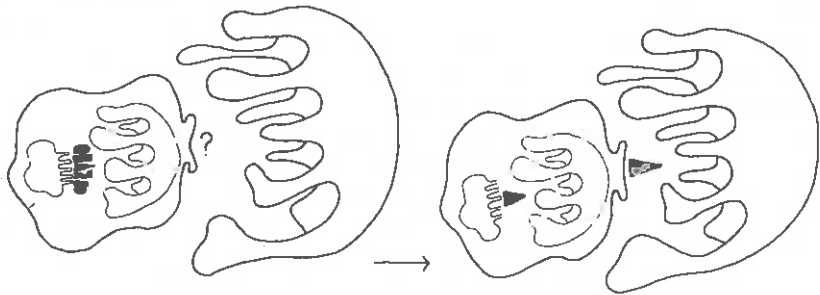

Popperian creature has an inner selective environment that previews candidate acts.

First time, the creature acts in a foresightful way (better than chance).

FIGURE 13.3

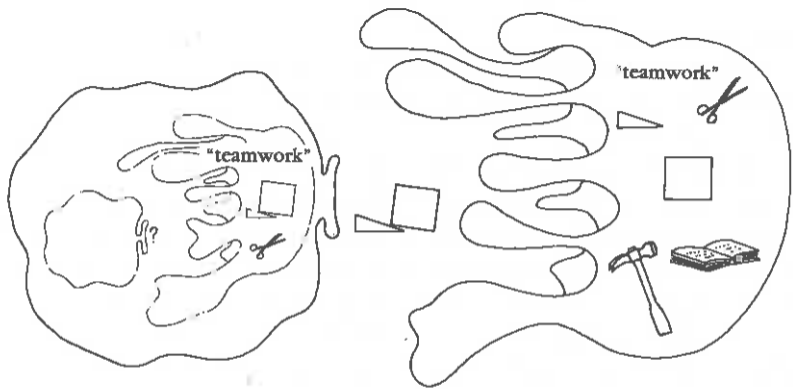

Gregorian creature imports mind-tools from the (cultural) environment; these improve both the generators and the testers.

FIGURE 13.4

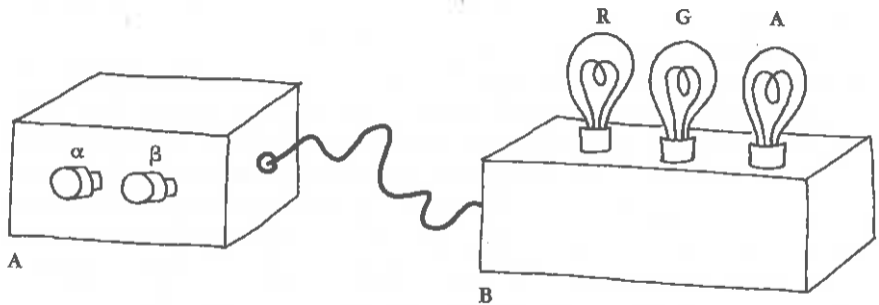

FIGURE 14.1



drinking beer

drinking Coke

25 years old

16 years old

Tell Me Why

Traditional



1. Tell me why the stars do shine,

2. Be - cause God made the stars to shine,



Tell me why the i ——— vy twines,

Be - cause God made the i ——— vy twine,



Tell me why the sky's so blue.

Be - cause God made the sky so blue.



Then I will tell you just why I love you.

Be - cause God made you, that's why I love you.

(The harmony line is usually sung by the higher voices an octave above the melody.)

Bibliography

- ABBOTT, E. A. 1884. *Flatland: A Romance in Many Dimensions*. Reprint ed., Oxford: Blackwell, 1962.
- ALEXANDER, RICHARD D. 1987. *The Biology of Moral Systems*. New York: de Gruyter.
- ARAB AND MUSLIM WRITERS. 1994. *For Rusbdie*. New York: Braziller.
- ARBIB, MICHAEL. 1964. *Brains, Machines, and Mathematics*. New York: McGraw-Hill.
- . 1989. *The Metaphorical Brain 2: Neural Networks and Beyond*. New York: Wiley.
- ARRHENIUS, S. 1908. *Worlds in the Making*. New York: Harper & Row.
- ASHBY, ROSS. 1960. *Design for a Brain*. New York: Wiley.
- AUSTIN, J. L. 1961. "A Plea for Excuses." In J. L. Austin, *Philosophical Papers*. Oxford: The Clarendon Press, pp. 123–52.
- AXELROD, ROBERT. 1984. *The Evolution of Cooperation*. New York: Basic Books.
- AXELROD, ROBERT, and HAMILTON, WILLIAM. 1981. "The Evolution of Cooperation." *Science*, vol. 211, pp. 1390–96.
- AYALA, FRANCISCO J. 1982. "Beyond Darwinism? The Challenge of Macroevolution to the Synthetic Theory of Evolution." In Peter D. Asquith and Thomas Nickels, eds., *PSA 1982* (Philosophy of Science Association), vol. 2, pp. 275–91. Reprinted in Ruse 1989.
- AYERS, M. 1968. *The Refutation of Determinism: An Essay in Philosophical Logic*. London: Methuen.
- BABBAGE, CHARLES. 1838. *Ninth Bridgewater Treatise: A Fragment*. London: Murray.
- BAK, PER; FLYVBJERG, HENRIK; and SNEPPEN, KIM. 1994. "Can We Model Darwin?" *New Scientist*, March 12, pp. 36–39.
- BALDWIN, J. M. 1896. "A New Factor in Evolution." *American Naturalist*, vol. 30, pp. 441–51, 536–53.
- BALL, JOHN A. 1984. "Memes as Replicators." *Ethology and Sociobiology*, vol. 5, pp. 145–61.

- BARKOW, JEROME H.; COSMIDES, LEDA; and TOOBY, JOHN. 1992. *The Adapted Mind: Evolutionary Psychology and the Generation of Culture*. Oxford: Oxford University Press.
- BARLOW, GEORGE W., and SILVERBERG, JAMES, eds. 1980. *Sociobiology: Beyond Nature/Nurture?* AAAS Selected Symposium. Boulder, Col.: Westview.
- BARON-COHEN, SIMON. 1995. *Mindblindness and the Language of the Eyes: An Essay in Evolutionary Psychology*. Cambridge, Mass.: MIT Press.
- BARRETT, P. H.; GAUTREY, P. J.; HERBERT, S.; KOHN, D.; and SMITH, S., eds. 1987. *Charles Darwin's Notebooks, 1836-44*. Cambridge: British Museum (Natural History)/Cambridge University Press.
- BARROW, J. and TIPLER, F. 1988. *The Anthropic Cosmological Principle*. Oxford: Oxford University Press.
- BATESON, WILLIAM. 1909. "Heredity and Variation in Modern Lights." In A. C. Seward, ed., *Darwin and Modern Science*. Cambridge: Cambridge University Press, pp. 85-101.
- BEDAU, MARK. 1991. "Can Biological Teleology Be Naturalized?" *Journal of Philosophy*, vol. 88, pp. 647-57.
- BENTHAM, JEREMY. 1789. *Introduction to the Principles of Morals and Legislation*. Oxford: Oxford University Press.
- BETHELL, TOM. 1976. "Darwin's Mistake." *Harper's Magazine*, February, pp. 70-75.
- BICKERTON, DEREK. 1993. "The Snail Wars" (review of Gould 1993d). *New York Times Book Review*, January 3, p. 5.
- BONNER, JOHN TYLER. 1980. *The Evolution of Culture in Animals*. Princeton: Princeton University Press.
- BORGES, JORGE LUIS. 1962. "The Library of Babel." In *Labyrinths: Selected Stories and Other Writings*. New York: New Directions. ("La Biblioteca de Babel," 1941. In *El jardín de los senderos que se bifurcan*, published as part of *Ficciones* [Buenos Aires: Emece Editores, 1956].)
- . 1993. "Poem About Quantity." Trans. Robert Mezey. *New York Review of Books*, June 24, p. 35.
- BRANDON, ROBERT. 1978. "Adaptation and Evolutionary Theory." *Studies in the History and Philosophy of Science*, vol. 9, pp. 181-206.
- BREUER, REINHARD. 1991. *The Anthropic Principle: Man as the Focal Point of Nature*. Boston: Birkhäuser.
- BRIGGS, DEREK E. G.; FORTEY, RICHARD A.; and WILLS, MATTHEW A. 1989. "Morphological Disparity in the Cambrian." *Science*, vol. 256, pp. 1670-73.
- BROOKS, RODNEY. 1991. "Intelligence Without Representation." *Artificial Intelligence Journal*, vol. 47, pp. 139-59.
- BRUMBAUGH, ROBERT M., and WELLS, RULON. 1968. *The Plato Manuscripts: A New Index*. New Haven: Yale University Press.
- BUSS, LEO W. 1987. *The Evolution of Individuality*. Princeton: Princeton University Press.
- CAIRNS-SMITH, GRAHAM. 1982. *Genetic Takeover*. Cambridge: Cambridge University Press.

- . 1985. *Seven Clues to the Origin of Life*. Cambridge: Cambridge University Press.
- CALVIN, WILLIAM. 1986. *The River That Flows Uphill: A Journey from the Big Bang to the Big Brain*. San Francisco: Sierra Club.
- . 1987. "The Brain as a Darwin Machine." *Nature*, vol. 330, pp. 33–34.
- CAMPBELL, DONALD. 1975. "On the Conflicts Between Biological and Social Evolution and Between Psychology and Moral Tradition." *American Psychologist*, December, pp. 1103–26.
- . 1979. "Comments on the Sociobiology of Ethics and Moralizing." *Behavioral Science*, vol. 24, pp. 37–45.
- CANN, REBECCA L.; STONEKING, MARK; and WILSON, ALLAN C. 1987. "Mitochondrial DNA and Human Evolution." *Nature*, vol. 325, pp. 31–36.
- CAPOTE, TRUMAN. 1965. *In Cold Blood*. New York: Random House.
- CARROLL, LEWIS. 1871. *Through the Looking Glass*. London: Macmillan.
- CHANGEAUX, J.-P., and DANCHIN, A. 1976. "Selective Stabilization of Developing Synapses as a Mechanism for the Specifications of a Neuronal Networks." *Nature*, vol. 264, pp. 705–12.
- CHOMSKY, NOAM. 1956. "Three Models for the Description of Language." *IRE Transactions on Information Theory IT-2(3)*, pp. 13–54.
- . 1957. *Syntactic Structures*. The Hague: Mouton.
- . 1959. Review of Skinner 1957. *Language*, vol. 35, pp. 26–58.
- . 1966. *Cartesian Linguistics*. New York: Harper & Row.
- . 1972. *Language and Mind*. Enlarged ed. New York: Harcourt Brace Jovanovich.
- . 1975. *Reflections on Language*. New York: Pantheon.
- . 1980. "Rules and Representations." *Behavioral and Brain Sciences*, vol. 3, pp. 1–15.
- . 1988. *Language and Problems of Knowledge: The Managua Lectures*. Cambridge, Mass.: MIT Press.
- CHRISTENSEN, SCOTT M., and TURNER, DALE R. 1993. *Folk Psychology and the Philosophy of Mind*. Hillsdale, N.J.: Erlbaum.
- CHURCHLAND, PATRICIA S., and SEJNOWSKI, TERRENCE, J. 1992. *The Computational Brain*. Cambridge, Mass.: MIT Press.
- CHURCHLAND, PAUL. 1989. *A Neurocomputational Perspective: The Nature of Mind and the Structure of Science*. Cambridge, Mass.: MIT Press.
- CLARK, ANDY, and KARMILOFF-SMITH, ANNETTE. 1994. "The Cognizer's Innards: A Psychological and Philosophical Perspective on the Development of Thought." *Mind & Language*, vol. 8, pp. 487–519.
- CLUTTON-BROCK, T. H., and HARVEY, PAUL H. 1978. *Readings in Sociobiology*. San Francisco: Freeman.
- CONWAY MORRIS, SIMON. 1989. "Burgess Shale Faunas and the Cambrian Explosion." *Science*, vol. 246, pp. 339–46.
- . 1991. "Rerunning the Tape" (review of Gould 1991b). *Times Literary Supplement*, December 13, p. 6.

- . 1992. "Burgess Shale-type Faunas in the Context of the 'Cambrian Explosion': A Review." *Journal of the Geological Society, London*, vol. 149, pp. 631–36.
- COON, C. S.; GARN, S. M.; and BIRDSELL, J. B. 1950. *Races*. Springfield, Ohio: C. Thomas.
- COSMIDES, LEDA, and TOOBY, JOHN. 1989, "Evolutionary Psychology and the Generation of Culture," pt. II, "Case Study: A Computational Theory of Social Exchange." *Ethology and Sociobiology*, vol. 10, pp. 51–97.
- CRICHTON, MICHAEL. 1990. *Jurassic Park*. New York: Knopf.
- CRICK, FRANCIS H. C. 1968. "The Origin of the Genetic Code." *Journal of Molecular Biology*, vol. 38, p. 367.
- . 1981. *Life Itself: Its Origin and Nature*. New York: Simon & Schuster.
- CRICK, FRANCIS, and ORGEL, LESLIE E. 1973. "Directed Panspermia." *Icarus*, vol. 19, pp. 341–46.
- CRONIN, HELENA. 1991. *The Ant and the Peacock*. Cambridge: Cambridge University Press.
- CUMMINS, ROBERT. 1975. "Functional Analysis." *Journal of Philosophy*, vol. 72, pp. 741–64. Reprinted in Sober 1984b.
- DALY, MARTIN. 1991. "Natural Selection Doesn't Have Goals, but It's the Reason Organisms Do" (commentary on P. J. H. Schoemaker, "The Quest for Optimality: A Positive Heuristic of Science?"). *Behavioral and Brain Sciences*, vol. 14, pp. 219–20.
- DANTO, ARTHUR. 1965. *Nietzsche as Philosopher*. New York: Macmillan.
- DARWIN, CHARLES. 1859. *On the Origin of Species by Means of Natural Selection*. London: Murray.
- . 1862. *On the Various Contrivances by Which Orchids Are Fertilised by Insects*. London: Murray. 2nd ed., 1877. (2nd ed. reprint, Chicago: University of Chicago Press, 1984.)
- . 1871. *The Descent of Man, and Selection in Relation to Sex*. London: Murray. 2nd ed., 1874.
- DARWIN, FRANCIS. 1911. *The Life and Letters of Charles Darwin*, 2 vols. New York: Appleton. (Originally published in 1887, in 3 vols., by Murray in London.)
- DAVID, PAUL. 1985. "Clio and the Economics of QWERTY." *American Economic Review*, vol. 75, pp. 332–37.
- DAVIES, PAUL. 1992. *The Mind of God*. New York: Simon & Schuster.
- DAWKINS, RICHARD. 1976. *The Selfish Gene*. Oxford: Oxford University Press. (See also revised ed., Dawkins 1989a.)
- . 1981. "In Defence of Selfish Genes." *Philosophy*, vol. 54, pp. 556–73.
- . 1982. *The Extended Phenotype: The Gene as the Unit of Selection*. Oxford and San Francisco: Freeman.
- . 1983a. "Universal Darwinism." In D. S. Bendall, ed., *Evolution from Molecules to Men* (Cambridge: Cambridge University Press), pp. 403–25.
- . 1983b. "Adaptationism Was Always Predictive and Needed No Defense"

- (commentary on Dennett 1983). *Behavioral and Brain Sciences*, vol. 6, pp. 360–61.
- . 1986a. *The Blind Watchmaker*. London: Longmans.
- . 1986b. "Sociobiology: The New Storm in a Teacup." In Steven Rose and Lisa Appignanesi, eds., *Science and Beyond* (Oxford: Blackwell), pp. 61–78.
- . 1989a. *The Selfish Gene* (2nd ed.) Oxford: Oxford University Press.
- . 1989b. "The Evolution of Evolvability." In C. Langton, ed., *Artificial Life*, vol. I (Redwood City, Calif.: Addison-Wesley), pp. 201–20.
- . 1990. Review of Gould 1989a. *Sunday Telegraph* (London), February 25.
- . 1993. "Viruses of the Mind." In Bo Dahlbom, ed., *Dennett and His Critics* (Oxford: Blackwell), pp. 13–27.
- DELIUS, JUAN. 1991. "The Nature of Culture." In M. S. Dawkins, T. R. Halliday, and R. Dawkins, eds., *The Tinbergen Legacy* (London: Chapman & Hall), pp. 75–99.
- DEMUS, OTTO. 1984. *The Mosaics of San Marco in Venice*, 4 vols. Chicago: University of Chicago Press.
- DENNETT, DANIEL C. 1968. "Machine Traces and Protocol Statements." *Behavioral Science*, vol. 13, pp. 155–61.
- . 1969. *Content and Consciousness*. London: Routledge & Kegan Paul.
- . 1970. "The Abilities of Men and Machines." Presented at American Philosophical Association Eastern Division Meeting, December. Published in Dennett 1978, pp. 256–66.
- . 1971. "Intentional Systems." *Journal of Philosophy*, vol. 68, pp. 87–106.
- . 1972. Review of Lucas 1970. *Journal of Philosophy*, vol. 69, pp. 527–31.
- . 1975. "Why the Law of Effect Will Not Go Away." *Journal of the Theory of Social Behaviour*, vol. 5, pp. 179–87. Reprinted in Dennett 1978.
- . 1978. *Brainstorms*. Cambridge, Mass.: MIT Press/A Bradford Book.
- . 1980. "Passing the Buck to Biology." *Behavioral and Brain Sciences*, vol. 3, p. 19.
- . 1981. "Three Kinds of Intentional Psychology." In R. Healey, ed., *Reduction, Time and Reality* (Cambridge: Cambridge University Press), pp. 37–61.
- . 1983. "Intentional Systems in Cognitive Ethology: The 'Panglossian Paradigm' Defended." *Behavioral and Brain Sciences*, vol. 6, pp. 343–90.
- . 1984. *Elbow Room: The Varieties of Free Will Worth Wanting*. Cambridge, Mass.: MIT Press.
- . 1985. "Can Machines Think?" In M. Shafto, ed., *How We Know* (San Francisco: Harper & Row), pp. 121–45.
- . 1987a. "The Logical Geography of Computational Approaches: A View from the East Pole." In M. Brand and M. Harnish, eds., *Problems in the*

- . 1987b. *The Intentional Stance*. Cambridge, Mass.: MIT Press/A Bradford Book.
- . 1988a. "When Philosophers Encounter Artificial Intelligence." *Daedalus*, vol. 117, pp. 283–95.
- . 1988b. "The Moral First Aid Manual." In Sterling M. McMurrin, ed., *Tanner Lectures on Human Values*, vol. VIII (Salt Lake City: University of Utah Press), pp. 120–47.
- . 1989a. Review of Robert J. Richards 1987. *Philosophy of Science*, vol. 56, no. 3, pp. 540–43.
- . 1989b. "Murmurs in the Cathedral" (review of Penrose 1989). *Times Literary Supplement*, September 26–October 5, pp. 1066–68.
- . 1990a. "Teaching an Old Dog New Tricks" (commentary on Schull 1990). *Behavioral and Brain Sciences*, vol. 13, pp. 76–77.
- . 1990b. "The Interpretation of Texts, People, and Other Artifacts." *Philosophy and Phenomenological Research*, vol. 50, pp. 177–94.
- . 1990c. "Memes and the Exploitation of Imagination." *Journal of Aesthetics and Art Criticism*, vol. 48, pp. 127–35.
- . 1991a. *Consciousness Explained*. Boston: Little, Brown.
- . 1991b. "Real Patterns." *Journal of Philosophy*, vol. 87, pp. 27–51.
- . 1991c. "Granny's Campaign for Safe Science." In B. Loewer and G. Rey, eds., *Meaning in Mind: Fodor and His Critics* (Oxford: Blackwell), pp. 87–94.
- . 1991d. "The Brain and Its Boundaries" (review of McGinn 1991). *Times Literary Supplement*, May 10, 1991 (corrected by erratum notice on May 24, p. 29).
- . 1991e. "Ways of Establishing Harmony." In B. McLaughlin, ed., *Dretske and His Critics* (Oxford: Blackwell); also (slightly revised) in E. Villanueva, ed., *Information, Semantics, and Epistemology*, Sociedad Filosófica Ibero-Americana (Mexico) (Oxford: Blackwell).
- . 1992. "La Compréhension artisanale." French translation of "Do-It-Yourself Understanding." In Denis Fiset, ed., *Daniel C. Dennett et les Stratégies Intentionnelles, Lektion*, vol. 11, winter, pp. 27–52.
- . 1993a. "Down with School! Up with Logoland!" (review of Papert 1993). *New Scientist*, November 6, pp. 45–46.
- . 1993b. "Confusion over Evolution: An Exchange." *New York Review of Books*, January 14, 1993, pp. 43–44.
- . 1993c. Review of John Searle 1992. *Journal of Philosophy*, vol. 90, pp. 193–205.
- . 1993d. "Living on the Edge." *Inquiry*, vol. 36, pp. 135–59.
- . 1994a. "Cognitive Science as Reverse Engineering: Several Meanings of 'Top-down' and 'Bottom-up.'" In D. Prawitz, B. Skyrms, and D. Westerståhl, eds., *Proceedings of the 9th International Congress of Logic, Methodology and Philosophy of Science* (Amsterdam: North-Holland).

- . 1994b. "Language and Intelligence." In Jean Khalfa, ed., *What Is Intelligence?* Cambridge: Cambridge University Press, pp. 161–78.
- . 1994c. "Labeling and Learning" (commentary on Clark and Karmiloff-Smith 1994). *Mind and Language*, vol. 8, pp. 540–48.
- . 1994d. "E Pluribus Unum?" *Behavioral and Brain Sciences*, vol. 17, pp. 617–18.
- . 1994e. "The Practical Requirements for Making a Conscious Robot." *Proceedings of the Royal Society*.
- DENNETT, DANIEL C., and HAUGELAND, JOHN. 1987. "Intentionality." In Gregory 1987, pp. 383–86.
- DENTON, MICHAEL. 1985. *Evolution: A Theory in Crisis*. London: Burnett.
- DESCARTES, RENÉ. 1637. *Discourse on Method*.
- DESMOND, ADRIAN, and MOORE, JAMES. 1991. *Darwin*. London: Michael Joseph.
- DEUTSCH, D. 1985. "Quantum Theory, the Church-Turing Principle and the Universal Quantum Computer." *Proceedings of the Royal Society*, vol. A400, pp. 97–117.
- DE VRIES, PETER. 1953. *The Vale of Laughter*. Boston: Little, Brown.
- DEWDNEY, A. K. 1984. *The Planiverse*. New York: Poseidon.
- DEWEY, JOHN. 1910. *The Influence of Darwin on Philosophy*. New York: Holt, 1910. Reprint ed., Bloomington: Indiana University Press, 1965.
- DIAMOND, JARED. 1991. "The Saltshaker's Curse." *Natural History*, October, pp. 20–26.
- . 1992. *The Third Chimpanzee: The Evolution and Future of the Human Animal*. New York: HarperCollins.
- DIDEROT, DENIS. 1749. *Letter on the Blind, for the Use of Those Who See*. Trans. and excerpted in J. Kemp, ed., *Diderot: Interpreter of Nature* (London: Lawrence and Wishart, 1937).
- DIETRICH, MICHAEL. 1992. "Macromutation." In Keller and Lloyd 1992, pp. 194–201.
- DIGGINS, JOHN PATRICK. 1994. Review of Marsden, *The Soul of the American University*. *New York Times Book Review*, April 17, p. 25.
- DOBZHANSKY, THEODOSIUS. 1973. "Nothing in Biology Makes Sense Except in the Light of Evolution." *American Biology Teacher*, vol. 35, pp. 125–29.
- DONALD, MERLIN. 1991. *Origins of the Modern Mind: Three Stages in the Evolution of Culture and Cognition*. Cambridge, Mass.: Harvard University Press.
- DOOLITTLE, W. F., and SAPIENZA, C. 1980. "Selfish Genes, the Phenotype Paradigm and Genome Evolution." *Nature*, vol. 284, pp. 601–3.
- DRETSKE, FRED. 1986. "Misrepresentation." In R. Bogdan, ed., *Belief*. Oxford: Oxford University Press.
- DREYFUS, HUBERT. 1965. "Alchemy and Artificial Intelligence." RAND Technical Report P-3244, December 1965.
- . 1972. *What Computers Can't Do: The Limits of Artificial Intelligence*. New York: Harper & Row. Revised ed., 1979.
- DYSON, FREEMAN. 1979. *Disturbing the Universe*. New York: Harper & Row.
- ECCLES, JOHN. 1953. *The Neurophysiological Basis of Mind*. Oxford: Clarendon.

- ECKERT, SCOTT A. 1992. "Bound for Deep Water." *Natural History*, March, pp. 28-35.
- EDELMAN, GERALD. 1987. *Neural Darwinism*. New York: Basic Books.
- . 1992. *Bright Air, Brilliant Fire*. New York: Basic Books.
- EDWARDS, PAUL. 1965. "Professor Tillich's Confusions." *Mind*, vol. 74, pp. 192-214.
- EIGEN, MANFRED. 1976. "Wie entsteht Information? Prinzipien der Selbstorganisation in der Biologie." *Berichtete der Bunsengesellschaft für Physikalische Chemie*, vol. 80, p. 1059.
- . 1983. "Self-Replication and Molecular Evolution." In D. S. Bendall, ed., *Evolution from Molecules to Men* (Cambridge: Cambridge University Press), pp. 105-30.
- . 1992. *Steps Towards Life*. Oxford: Oxford University Press.
- EIGEN, M. and WINKLER-OSWATITSCH, R. 1975. *Das Spiel*. Munich. (English trans., *Laws of the Game* [New York: Knopf, 1981]).
- EIGEN, M., and SCHUSTER, P. 1977. "The Hypercycle: A Principle of Natural Self-Organization. Part A: Emergence of the Hypercycle," *Naturwissenschaften*, vol. 64, pp. 541-65.
- ELDRIDGE, NILES. 1983. "A la recherche du Docteur Pangloss" (commentary on Dennett 1983). *Behavioral and Brain Sciences*, vol. 6, pp. 361-62.
- . 1985. *Time Frames: The Rethinking of Darwinian Evolution and the Theory of Punctuated Equilibria*. New York: Simon & Schuster.
- . 1989. *Macroevolutionary Dynamics: Species, Niches and Adaptive Peaks*. New York: McGraw-Hill.
- ELDRIDGE, NILES, and GOULD, S. J. 1972. "Punctuated Equilibria: An Alternative to Phyletic Gradualism." In T. J. M. Schopf, ed., *Models in Paleobiology* (San Francisco: Freeman, Cooper and Company), pp. 82-115. Reprinted in Eldredge 1985, pp. 193-223.
- ELLEGARD, ALVAR. 1956. "The Darwinian Theory and the Argument from Design." *Lychnos*, pp. 173-92.
- . 1958. *Darwin and the General Reader*. Goteborg: Goteborg University Press.
- ELLESTRAND, NORMAN. 1983. "Why Are Juveniles Smaller Than Their Parents?" *Evolution*, vol. 13, pp. 1091-94.
- ELLIS, R. J., and VAN DER VIES, S. M. 1991. "Molecular Chaperones." *Annual Review of Biochemistry*, vol. 60, pp. 321-47.
- ELSASSER, WALTER. 1958. *The Physical Foundations of Biology*. Oxford: Oxford University Press.
- . 1966. *Atom and Organism*. Princeton: Princeton University Press.
- ENGELS, W. R. 1992. "The Origin of P Elements in *Drosophila melanogaster*." *BioEssays*, vol. 14, pp. 681-86.
- ERESHEFSKY, MARC, ed. 1992. *The Units of Evolution: Essays on the Nature of Species*. Cambridge, Mass.: MIT Press/A Bradford Book.
- ESHEL, I. 1984. "Are Intragenetic Conflicts Common in Nature? Do They Repre-

- sent an Important Factor in Evolution?" *Journal of Theoretical Biology*, vol. 108, pp. 159–62.
- . 1985. "Evolutionary Genetic Stability of Mendelian Segregation and the Role of Free Recombination in the Chromosomal System." *American Naturalist*, vol. 125, pp. 412–20.
- FAUSTO-STERLING, ANNE. 1985. *Myths of Gender: Biological Theories About Women and Men*. New York: Basic Books. (2nd ed., 1992.)
- FEDUCCIA, ALAN. 1993. "Evidence from Claw Geometry Indicating Arboreal Habits of *Archeopteryx*." *Science*, vol. 259, pp. 790–93.
- FEIGENBAUM, E. A., and FELDMAN, J. 1964. *Computers and Thought*. New York: McGraw-Hill.
- FEYNMAN, RICHARD. 1988. *What do YOU Care What Other People Think?* New York: Bantam.
- FISHER, DAN. 1975. "Swimming and Burrowing in *Limulus* and *Mesolimulus*." *Fossils and Strata*, vol. 4, pp. 281–90.
- FISHER, R. A. 1930. *The Genetical Theory of Natural Selection*. Oxford: Clarendon.
- FITCHEN, JOHN. 1961. *The Construction of Gothic Cathedrals*. Oxford: Clarendon.
- . 1986. *Building Construction Before Mechanization*. Cambridge, Mass.: MIT Press.
- FODOR, JERRY. 1975. *The Language of Thought*. Hassocks, Sussex: Harvester.
- . 1980. "Methodological Solipsism Considered as a Research Strategy in Cognitive Psychology." *Behavioral and Brain Sciences*, vol. 3, pp. 63–110.
- . 1983. *The Modularity of Mind*. Cambridge, Mass.: MIT Press.
- . 1987. *Psychosemantics*. Cambridge, Mass.: MIT Press.
- . 1990. *A Theory of Content and Other Essays*. Cambridge, Mass.: MIT Press.
- . 1992. "The Big Idea: Can There Be a Science of Mind?" *Times Literary Supplement*, July 3, p. 5.
- FOOTE, MIKE. 1992. "Cambrian and Recent Morphological Disparity" (response to Briggs et al. 1989). *Science*, vol. 256, p. 1670.
- FORBES, GRAEME. 1983. "Thisness and Vagueness," *Synthese*, vol. 54, pp. 235–59.
- . 1984. "Two Solutions to Chisholm's Paradox." *Philosophical Studies*, vol. 46, pp. 171–87.
- FOX, S. W., and DOSE, K. 1972. *Molecular Evolution and the Origin of Life*. San Francisco: Freeman.
- FUTUYMA, DOUGLAS. 1982. *Science on Trial: The Case for Evolution*. New York: Pantheon.
- GABBEY, ALLAN. 1993. "Descartes, Newton and Mechanics: The Disciplinary Turn." Tufts Philosophy Colloquium, November 12.
- GALILEI, GALILEO. 1632. *Dialogue Concerning the Two Chief World Systems*. Florence.
- GARDNER, MARTIN. 1970. "Mathematical Games." *Scientific American*, October, vol. 223, 120–23.

- . 1971. "Mathematical Games." *Scientific American*, vol. 224, February, pp. 112–17.
- . 1986. "WAP, SAP, PAP and FAP." *New York Review of Books*, May 8. (Reprinted with a postscript in Martin Gardner, *Gardner's Whys and Wherefores*. Chicago: University of Chicago Press, 1989.)
- GAUTHIER, DAVID. 1986. *Morals by Agreement*. New York: Oxford University Press.
- GEE, HENRY. 1992. "Something Completely Different." *Nature*, vol. 358, pp. 456–57.
- GERT, BERNARD. 1973. *The Moral Rules*. New York: Harper Torchbook. Original ed., New York: Harper & Row, 1966.
- GHISELIN, M. 1983. "Lloyd Morgan's Canon in Evolutionary Context." *Behavioral and Brain Sciences*, vol. 6, pp. 362–63.
- GIBBARD, ALAN. 1985. "Moral Judgment and the Acceptance of Norms," and "Reply to Sturgeon." *Ethics*, vol. 96, pp. 5–41.
- GILKEY, LANGDON. 1985. *Creationism on Trial: Evolution and God at Little Rock*. San Francisco: Harper & Row.
- GILLE, BERTRAND. 1966. *Engineers of the Renaissance*. Cambridge, Mass.: MIT Press.
- GINGERICH, PHILIP. 1983. "Rate of Evolution: Effects of Time and Temporal Scaling." *Science*, vol. 222, pp. 159–61.
- . 1984. Reply to Gould 1983c. *Science*, vol. 226, pp. 995–96.
- GJERTSEN, DEREK. 1989. *Science and Philosophy: Past and Present*. London: Penguin.
- GÖDEL, KURT. 1931. "Über Formal Unentscheidbare Sätze der *Principia Mathematica* und Verwandter System, I." *Monatshefte für Mathematik und Physik*, vol. 38, pp. 173–98. Translated and published, with some discussion, as *On Formally Undecidable Propositions* (New York: Basic Books, 1962).
- GODFREY-SMITH, PETER. 1993. "Spencerian Explanation and Constructivism." MIT Philosophy Colloquium, November 5.
- GOLDSCHMIDT, RICHARD B. 1933. "Some Aspects of Evolution." *Science*, vol. 78, pp. 539–47.
- . 1940. *The Material Basis of Evolution*. Seattle: University of Washington Press.
- GOODMAN, NELSON. 1965. *Fact, Fiction and Forecast*. 2nd ed. New York: Bobbs-Merrill.
- GOODWIN, BRIAN. 1986. "Is Biology an Historical Science?" In Steven Rose and Lisa Appignanesi, eds., *Science and Beyond* (Oxford: Blackwell), pp. 47–60.
- GOULD, STEPHEN JAY. 1977a. *Ever Since Darwin*. New York: Norton.
- . 1977b. *Ontogeny and Phylogeny*. Cambridge: Belknap.
- . 1980a. *The Panda's Thumb*. New York: Norton.
- . 1980b. "Is a New and General Theory of Evolution Emerging?" *Paleobiology*, vol. 6, pp. 119–30.
- . 1980c. "Sociobiology and the Theory of Natural Selection." *American Association for the Advancement of Science Symposia*, vol. 35, pp. 257–69. Reprinted in Ruse 1989.

- . 1980d. "The Evolutionary Biology of Constraint." *Daedalus*, vol. 109, pp. 39–52.
- . 1981. *The Mismeasure of Man*. New York: Norton.
- . 1982a. "Darwinism and the Expansion of Evolutionary Theory." *Science*, vol. 216, pp. 380–87. Reprinted in Ruse 1989.
- . 1982b. "The Uses of Heresy: An Introduction to Richard Goldschmidt's *The Material Basis of Evolution*." In R. Goldschmidt, *The Material Basis of Evolution* (reprinted ed., New Haven: Yale University Press).
- . 1982c. "The Meaning of Punctuated Equilibrium, and Its Role in Validating a Hierarchical Approach to Macroevolution." In R. Milkman, ed., *Perspectives on Evolution* (Sunderland, Mass.: Sinauer), pp. 83–104.
- . 1982d. "Change in Developmental Timing as a Mechanism of Macroevolution." In J. T. Bonner, ed., *Evolution and Development*, Dahlem Konferenzen (Berlin, Heidelberg, New York: Springer-Verlag).
- . 1983a. "The Hardening of the Modern Synthesis." In M. Grene, ed., *Dimensions of Darwinism*. Cambridge: Cambridge University Press, pp. 71–93.
- . 1983b. *Hen's Teeth and Horse's Toes*. New York: Norton.
- . 1983c. "Smooth Curve of Evolutionary Rate: A Psychological and Mathematical Artifact." *Science*, vol. 226, pp. 994–95.
- . 1985. *The Flamingo's Smile*. New York: Norton.
- . 1987. "Darwinism Defined: The Difference Between Fact and Theory." *Discover*, January pp. 64–70.
- . 1989a. *Wonderful Life: The Burgess Shale and the Nature of History*. New York: Norton.
- . 1989b. "Tires to Sandals." *Natural History*, April, pp. 8–15.
- . 1990. *The Individual in Darwin's World*. Edinburgh: Edinburgh University Press. (This is a direct transcription, "by Ian Wall, Ian Rolfe and Simon Gage of the City of Edinburgh District Council," of what was obviously a largely extemporaneous talk.)
- . 1991a. "The Panda's Thumb of Technology." In Gould 1991b, pp. 59–75.
- . 1991b. *Bully for Brontosaurus*. New York: Norton.
- . 1992a. "The Confusion over Evolution." *New York Review of Books*, November 19, pp. 47–54.
- . 1992b. "Life in a Punctuation." *Natural History*, vol. 101. October, pp. 10–21.
- . 1993a. "Fulfilling the Spandrels of World and Mind." In Selzer 1993, pp. 310–36.
- , ed. 1993b. *The Book of Life*. New York: Norton.
- . 1993c. "Cordelia's Dilemma." *Natural History*, vol. 103, February, pp. 10–19.
- . 1993d. *Eight Little Piggies*. New York: Norton.
- . 1993e. "Confusion over Evolution: An Exchange." *New York Review of Books*, January 14, pp. 43–44.

- GOULD, S. J., and ELDRIDGE, N. 1993. "Punctuated Equilibrium Comes of Age." *Nature*, vol. 366, pp. 223-27.
- GOULD, S. J., and LEWONTIN, R. 1979. "The Spandrels of San Marco and the Panglossian Paradigm: A Critique of the Adaptationist Programme." *Proceedings of the Royal Society*, vol. B205, pp. 581-98.
- GOULD, S. J., and VRBA, ELIZABETH. 1981. "Exaptation: A Missing Term in the Science of Form." *Paleobiology*, vol. 8, pp. 4-15.
- GREENWOOD, JOHN D., ed. 1991. *The Future of Folk Psychology: Intentionality and Cognitive Science*. Cambridge: Cambridge University Press.
- GREGORY, R. L. 1981. *Mind in Science: A History of Explanations in Psychology and Physics*. Cambridge: Cambridge University Press.
- , ed. 1987. *The Oxford Companion to the Mind*. Oxford: Oxford University Press.
- GRICE, H. P. 1957. "Meaning." *Philosophical Review*, vol. 66, pp. 377-88.
- . 1969. "Utterer's Meaning and Intentions." *Philosophical Review*, vol. 78, pp. 147-77.
- GROSSBERG, STEPHEN. 1976. "Adaptive Pattern Classification and Universal Recording: Part I. Parallel Development and Coding of Neural Feature Detectors." *Biological Cybernetics*, vol. 23, pp. 121-34.
- HADAMARD, JACQUES. 1949. *The Psychology of Inventing in the Mathematical Field*. Princeton: Princeton University Press.
- HAIG, DAVID. 1992. "Genomic Imprinting and the Theory of Parent-Offspring Conflict." *Developmental Biology*, vol. 3, pp. 153-60.
- . 1993. "Genetic Conflicts in Human Pregnancy." *Quarterly Review of Biology*, vol. 68, pp. 495-532.
- HAIG, DAVID, and GRAFEN, A. 1991. "Genetic Scrambling as a Defence Against Meiotic Drive." *Journal of Theoretical Biology*, vol. 153, pp. 531-58.
- HAIG, DAVID, and GRAHAM, CHRIS. 1991. "Genomic Imprinting and the Strange Case of the Insulin-like Growth Factor II Receptor." *Cell*, vol. 64, pp. 1045-46.
- HAIG, DAVID, and WESTOBY, M. 1989. "Parent-specific Gene Expression and the Triploid Endosperm." *American Naturalist*, vol. 134, pp. 147-55.
- HALE, KEN, et al. 1992. "Endangered Languages." *Language*, vol. 68, pp. 1-42.
- HAMILTON, WILLIAM. 1964. "The Genetical Evolution of Social Behavior," pts. I and II. *Journal of Theoretical Biology*, vol. 7, pp. 1-16, 17-52.
- HARDIN, GARRETT. 1964. "The Art of Publishing Obscurely." In G. Hardin, ed., *Population, Evolution and Birth Control: A Collection of Controversial Readings* (San Francisco: Freeman), pp. 116-19.
- . 1968. "The Tragedy of the Commons." *Science*, vol. 162, pp. 1243-48.
- HARDY, ALISTER., 1960. "Was Man More Aquatic in the Past?" *New Scientist*, pp. 642-45.
- HAUGELAND, JOHN. 1985. *Artificial Intelligence: The Very Idea*. Cambridge, Mass.: MIT Press.
- HAWKING, STEPHEN W. 1988. *A Brief History of Time*. New York: Bantam.
- HEBB, DONALD. 1949. *The Organization of Behavior*. New York: Wiley.

- HINTON, GEOFFREY E., and NOWLAND, S. J. 1987. "How Learning Can Guide Evolution." In *Complex Systems*, vol. I. Technical report CMU-CS-86-128. Carnegie-Mellon University, pp. 495-502.
- HOBBS, THOMAS. 1651. *Leviathan*. London: Crooke.
- HODGES, ANDREW. 1983. *Alan Turing: The Enigma*. New York: Simon & Schuster.
- HOFSTADTER, DOUGLAS. 1979. *Gödel Escher Bach*. New York: Basic Books.
- . 1985. *Metamagical Themas: Questing for the Essence of Mind and Pattern*. New York: Basic Books.
- HOFSTADTER, DOUGLAS R., and DENNETT, DANIEL C. 1981. *The Mind's I*. New York: Basic Books.
- HOLLAND, JOHN. 1975. *Adaptation in Natural and Artificial Systems*. Ann Arbor: University of Michigan Press.
- . 1992. "Complex Adaptive Systems." *Daedalus*, Winter, p. 25.
- HOLLINGDALE, R. J. 1965. *Nietzsche: The Man and His Philosophy*. London: Routledge & Kegan Paul.
- HOUCK, MARILYN A.; CLARK, JONATHAN B.; PETERSON, KENNETH R.; and KIDWELL, MARGARET G. 1991. "Possible Horizontal Transfer of *Drosophila* Genes by the Mite *Proctolaelaps Regalis*." *Science*, vol. 253, pp. 1125-29.
- HOUSTON, ALASDAIR. 1990. "Matching, Maximizing, and Melioration as Alternative Descriptions of Behaviour." In J. A. Meyer and S. Wilson, eds., *From Animals to Animats*. Cambridge, Mass.: MIT Press, pp. 498-509.
- HOY, DAVID. 1986. "Nietzsche, Hume, and the Genealogical Method." In Y. Yovel, ed., *Nietzsche as Affirmative Thinker* (Dordrecht: Martinus Nijhoff), pp. 20-38.
- HOYLE, FRED. 1964. *Of Men and Galaxies*. Seattle: University of Washington Press.
- HOYLE, FRED, and WICKRAMASINGHE, CHANDRA. 1981. *Evolution from Space*. London: Dent.
- HRDY, SARAH BLAFFER. 1977. *The Langurs of Abu: Female and Male Strategies of Reproduction*. Cambridge, Mass.: Harvard University Press.
- HULL, DAVID. 1980. "Individuality and Selection." *Annual Review of Ecology and Systematics*, vol. 11, pp. 311-32.
- . 1982. "The Naked Meme." In H. C. Plotkin, ed., *Learning, Development and Culture* (New York: Wiley), pp. 273-327.
- HUME, DAVID. 1739. *A Treatise of Human Nature*. Ed. L. A. Selby-Bigge. Oxford: Clarendon, 1964.
- . 1779. *Dialogues Concerning Natural Religion*. London.
- HUMPHREY, NICHOLAS. 1976. "The Social Function of Intellect." In P. P. G. Bateson and R. A. Hinde, eds., *Growing Points in Ethology* (Cambridge: Cambridge University Press), pp. 303-17.
- . 1983. "The Adaptiveness of Mentalism?" *Behavioral and Brain Sciences*, vol. 3, p. 366.
- . 1986. *The Inner Eye*. London: Faber & Faber.
- . 1987. "Scientific Shakespeare." *Guardian* (London), August 26.
- ISACK, H. A., and REYER, H.-U. 1989. "Honeyguides and Honey Gatherers: Inter-

- specific Communication in a Symbiotic Relationship." *Science*, vol. 243, pp. 1343–46.
- ISRAEL, DAVID. 1987. *The Role of Propositional Objects of Belief in Action*. CSLI Monograph Report no. CSLI-87-72. Palo Alto: Stanford University Press.
- JACKENDOFF, RAY. 1987. *Consciousness and the Computational Mind*. Cambridge, Mass.: MIT Press/A Bradford Book.
- . 1993. *Patterns in the Mind: Language and Human Nature*. London: Harvester Wheatsheaf.
- JACOB, FRANÇOIS. 1982. *The Possible and the Actual*. Seattle: University of Washington Press.
- . 1983. "Molecular Tinkering in Evolution." In D. S. Bendall, ed., *Evolution from Molecules to Men* (Cambridge: Cambridge University Press), pp. 131–44.
- JAMES, WILLIAM. 1880. *Lecture Notes 1880–1897*. (The quoted passage is from Sills and Merton 1991.)
- JAYNES, JULIAN. 1976. *The Origins of Consciousness in the Breakdown of the Bicameral Mind*. Boston: Houghton Mifflin.
- JONES, STEVE. 1993. "A Slower Kind of Bang" (review of E. O. Wilson, *The Diversity of Life*). *London Review of Books*, April, p. 20.
- KANT, IMMANUEL. 1785. *Grundlegung zur Metaphysik der Sitten*. (The quoted passage is from the translation of H. J. Paton, *Groundwork of the Metaphysic of Morals* [New York: Harper & Row, 1964].)
- KAUFFMAN, STUART. 1993. *The Origins of Order: Self-Organization and Selection in Evolution*. New York: Oxford University Press.
- KAUFMANN, WALTER. 1950. *Nietzsche: Philosopher, Psychologist, Antichrist*. Princeton: Princeton University Press. Reprint ed., New York: Meridian paperback, 1956.
- KEIL, FRANK, C. 1992. "The Origins of an Autonomous Biology." In M. Gunnar and M. Maratsos, eds., *Modularity and Constraints in Language and Cognition: The Minnesota Symposia on Child Psychology*, vol. 25. Hillsdale, N.J.: Erlbaum, pp. 103–37.
- KELLER, EVELYN FOX, and LLOYD, ELISABETH A., eds. 1992. *Keywords in Evolutionary Biology*. Cambridge, Mass.: Harvard University Press.
- KING'S COLLEGE SOCIOBIOLOGY GROUP. 1982. *Current Problems in Sociobiology*. Cambridge: Cambridge University Press.
- KIPLING, RUDYARD. 1912. *Just So Stories*. Reprint ed., Garden City, N.Y.: Doubleday, 1952.
- KIRKPATRICK, S.; GELATT, C. D.; and VECCHI, M. P. 1983. "Optimization by Simulated Annealing." *Science*, vol. 220, pp. 671–80.
- KITCHER, PHILIP. 1982. *Abusing Science*. Cambridge, Mass.: MIT Press.
- . 1984. "Species." *Philosophy of Science*, vol. 51, pp. 308–33.
- . 1985a. "Darwin's Achievement." In N. Rescher, ed., *Reason and Rationality in Science* (Lanham, Md.: University Press of America), pp. 127–89.
- . 1985b. *Vaulting Ambition*. Cambridge, Mass.: MIT Press.

- . 1993. "The Evolution of Human Altruism." *Journal of Philosophy*, vol. 90, pp. 497–516.
- KRAUTHIMER, RICHARD. 1981. *Early Christian and Byzantine Architecture*. 3rd ed. London: Penguin.
- KREBS, JOHN R., and DAWKINS, RICHARD. 1984. "Animal Signals: Mind-Reading and Manipulation." In J. R. Krebs and N. B. Davies, eds., *Behavioural Ecology: An Evolutionary Approach*, 2nd ed. (Oxford: Blackwell), pp. 380–402.
- KÜPPERS, BERND-OLAF. 1990. *Information and the Origin of Life*. Cambridge, Mass.: MIT Press.
- LANCASTER, JANE. 1975. *Primate Behavior and the Emergence of Human Culture*. New York: Holt, Rinehart and Winston.
- LANDMAN, OTTO E. 1991. "The Inheritance of Acquired Characteristics." *Annual Review of Genetics*, vol. 25, pp. 1–20.
- . 1993. "Inheritance of Acquired Characteristics." *Scientific American*, March, p. 150.
- LANGTON, CHRISTOPHER; TAYLOR, CHARLES; FARMER, J. DOYNE; and RASMUSSEN, STEEN. 1992. *Artificial Life II*. Redwood City, Calif.: Addison-Wesley.
- LEIBNIZ, GOTTFRIED WILHELM. 1710. *Theodicy (Essais de Théodicée sur la bonté de Dieu, la liberté de l'homme et l'origine du mal)*, Amsterdam. (George Martin Duncan translation, 1908.)
- LEIGH, E. G. 1971. *Adaptation and Diversity*. San Francisco: Freeman, Cooper and Company.
- LENAT, DOUGLAS B., and GUHA, R. V. 1990. *Building Large Knowledge-based Systems: Representation and Inference in the CYC Project*. Reading, Mass.: Addison-Wesley.
- LESLIE, ALAN. 1992. "Pretense, Autism and the Theory-of-Mind Module." *Current Directions in Psychological Science*, vol. 1, pp. 18–21.
- LESLIE, JOHN. 1989. *Universes*, London: Routledge & Kegan Paul.
- LEITVIN, J. Y.; MATURANA, U.; McCULLOCH, W.; and PITTS, W. 1959. "What the Frog's Eye Tells the Frog's Brain." In *Proceedings of the IRE*, pp. 1940–51.
- LEVI, PRIMO. 1984. *The Periodic Table*. New York: Schocken.
- LÉVI-STRAUSS, CLAUDE. 1966. *The Savage Mind*. Chicago: University of Chicago Press.
- LEWIN, ROGER. 1992. *Complexity: Life at the Edge of Chaos*. New York: Macmillan.
- LEWIS, DAVID. 1986. *Philosophical Papers*, vol. 2. Oxford: Oxford University Press.
- LEWONTIN, RICHARD. 1980. "Adaptation." *The Encyclopedia Einaudi*. Milan: Einaudi.
- . 1983. "Elementary Errors About Evolution" (commentary on Dennett 1983). *Behavioral and Brain Sciences*, vol. 6, pp. 367–68.
- . 1987. "The Shape of Optimality." In John Dupré, ed., *The Latest on the Best: Essays on Evolution and Optimality*. Cambridge, Mass.: MIT Press.
- LEWONTIN, RICHARD; ROSE, STEVEN; and KAMIN, LEON. 1984. *Not in our Genes: Biology, Ideology and Human Nature*. New York: Pantheon.

- LINNAEUS, CAROLUS. 1751. *Philosophia Botanica*.
- LOYD, M., and DYBAS, H. S. 1966. "The Periodical Cicada Problem." *Evolution*, vol. 20, pp. 132-49.
- LOCKE, JOHN. 1690. *Essay Concerning Human Understanding*. London.
- LORD, ALBERT. 1960. *The Singer of Tales*. Cambridge, Mass.: Harvard University Press.
- LORENZ, KONRAD. 1973. *Die Rückseite des Spiegels*. Munich: R. Piper. Verlag. (English trans. by Ronald Taylor, *Behind the Mirror* [New York: Harcourt Brace Jovanovich, 1977].)
- LOVEJOY, ARTHUR O. 1936. *The Great Chain of Being: A Study of the History of an Idea*. New York: Harper & Row.
- LUCAS, J. R. 1961. "Minds, Machines, and Gödel." *Philosophy*, vol. 36, pp. 1-12.
- . 1970. *The Freedom of the Will*. Oxford: Oxford University Press.
- MACKENZIE, ROBERT BEVERLEY. 1868. *The Darwinian Theory of the Transmutation of Species Examined* (published anonymously "By a Graduate of the University of Cambridge"). Nisbet & Co. (Quoted in a review, *Athenaeum*, no. 2102, February 8, p. 217.)
- MALTHUS, THOMAS. 1798. *Essay on the Principle of Population*.
- MARGOLIS, HOWARD. 1987. *Patterns, Thinking and Cognition*. Chicago: University of Chicago Press.
- MARGULIS, LYNN. 1981. *Symbiosis in Cell Evolution*. San Francisco: Freeman.
- MARGULIS, LYNN, and SAGAN, DORION. 1986. *Microcosmos*. New York: Simon & Schuster.
- . 1987. "Bacterial Bedfellows." *Natural History*, vol. 96, March, pp. 26-33.
- MARKS, JONATHAN. 1993. Review of Diamond 1992. *Journal of Human Evolution*, vol. 24, pp. 69-73.
- . 1993b. "Scientific Misconduct: Where 'Just Say No' Fails" (multiple book review). *American Scientist*, vol. 81, July-August, pp. 380-82.
- MARTIN, J.; MAYHEW, M.; LANGER, T.; and HARTL, F. U. 1993. "The Reaction Cycle of GroEL and GroES in Chaperonin-assisted Protein Folding." *Nature*, vol. 366, pp. 228-33.
- MASSERMAN, JULES H.; WECHKIN, STANLEY; and TERRIS, WILLIAM. 1964. "'Altruistic' Behavior in Rhesus Monkeys." *American Journal of Psychiatry*, vol. 121, pp. 584-85.
- MATTHEW, PATRICK. 1831. *Naval Timber and Arboriculture*.
- . 1860. Letter to editor, *Gardener Chronicle*, April 7.
- MAYNARD SMITH, JOHN. 1958. *The Theory of Evolution*. Cambridge: Cambridge University Press. (Canto ed. 1993.)
- . 1972. *On Evolution*. Edinburgh: Edinburgh University Press.
- . 1974. "The Theory of Games and the Evolution of Animal Conflict." *Journal of Theoretical Biology*, vol. 47, pp. 209-21.
- . 1978. *The Evolution of Sex*. Cambridge: Cambridge University Press.
- . 1979. "Hypercycles and the Origin of Life." *Nature*, vol. 280, pp. 445-46. Reprinted in Maynard Smith 1982, pp. 34-38.

- . 1981. "Symbolism and Chance." In J. Agassi and R. S. Cohen, eds., *Scientific Philosophy Today* (Hingham, Mass: Kluwer). Reprinted in Maynard Smith 1988, pp. 15–21.
- . 1982. *Evolution Now: A Century After Darwin*. San Francisco: Freeman.
- . 1983. "Adaptation and Satisficing" (commentary on Dennett 1983). *Behavioral and Brain Sciences*, vol. 6, pp. 70–71.
- . 1986. "Structuralism Versus Selection—Is Darwinism Enough?" In Steven Rose and Lisa Appignanesi, eds. *Science and Beyond* (Oxford: Blackwell), pp. 39–46.
- . 1988. *Games, Sex and Evolution*. London: Harvester. (Also published under the title *Did Darwin Get it Right?*)
- . 1990. "What Can't the Computer Do?" (review of Penrose 1989). *New York Review of Books*, March 15, pp. 21–25.
- . 1991. "Dinosaur Dilemmas." *New York Review of Books*, April 25, pp. 5–7.
- . 1992. "Taking a Chance on Evolution." *New York Review of Books*, May 14, pp. 234–36.
- MAYR, ERNST. 1960. "The Emergence of Evolutionary Novelties." In Sol Tax, ed., *Evolution after Darwin*, vol. 1 (Chicago: University of Chicago Press), pp. 349–80.
- . 1982. *The Growth of Biological Thought*. Cambridge, Mass.: Harvard University Press.
- . 1983. "How to Carry Out the Adaptationist Program." *American Naturalist*, vol. 121, pp. 324–34.
- MAZLISH, BRUCE. 1993. *The Fourth Discontinuity: The Co-evolution of Humans and Machines*. New Haven: Yale University Press.
- MCCULLOCH, W. S., and PITTS, W. 1943. "A Logical Calculus of the Ideas Immanent in Nervous Activity." *Bulletin of Mathematical Biophysics*, vol. 5, pp. 115–33.
- MCGINN, COLIN. 1991. *The Problem of Consciousness*. Oxford: Blackwell.
- . 1993. "In and Out of the Mind" (review of Hilary Putnam, *Renewing Philosophy*). *London Review of Books*, December 2, pp. 30–31.
- MCLAUGHLIN, BRIAN, ed. 1991. *Dretske and His Critics*. Oxford: Blackwell.
- MCSHEA, DANIEL W. 1993. "Arguments, Tests, and the Burgess Shale—A Commentary on the Debate." *Paleobiology*, vol. 9, pp. 339–402.
- MEDAWAR, PETER. 1977. "Unnatural Science." *The New York Review of Books*, February 3, pp. 13–18.
- . 1982. *Pluto's Republic*. Oxford: Oxford University Press.
- METROPOLIS, NICHOLAS. 1992. "The Age of Computing: A Personal Memoir." *Daedalus*, Winter, pp. 119–30.
- MIDGLEY, MARY. 1979. "Gene-Juggling." *Philosophy*, vol. 54, pp. 439–58.
- . 1983. "Selfish Genes and Social Darwinism." *Philosophy*, vol. 58, pp. 365–77.
- MILL, JOHN STUART. 1861. *Utilitarianism*. Originally published in *Fraser's Magazine*; reprinted 1863.

- MILLER, GEORGE A. 1956. "The Magical Number Seven, Plus or Minus Two." *Psychological Review*, vol. 63, pp. 81–97.
- . 1979. "A Very Personal History." MIT Cognitive Science Center Occasional Paper #1, a talk to the Cognitive Science Workshop, June 1, 1979.
- MILLIKAN, RUTH. 1984. *Language, Thought and Other Biological Categories*. Cambridge, Mass.: MIT Press.
- . 1993. *White Queen Psychology and Other Essays for Alice*. Cambridge, Mass.: MIT Press.
- MINSKY, MARVIN. 1985a. "Why Intelligent Aliens Will Be Intelligible." In E. Regis, ed., *Extraterrestrials* (Cambridge: Cambridge University Press), pp. 117–28.
- MINSKY, MARVIN. 1985b. *The Society of Mind*. New York: Simon & Schuster.
- MINSKY, MARVIN, and PAPERT, SEYMOUR. 1969. *Perceptrons*. Cambridge, Mass.: MIT Press.
- MIVART, ST. GEORGE. 1871. "Darwin's *Descent of Man*." *Quarterly Review*, vol. 131, pp. 47–90.
- MONOD, JACQUES. 1971. *Chance and Necessity*. New York: Knopf. Vintage paperback, 1972. (Originally published in France as *Le Hasard et la nécessité* [Paris: Editions du Seuil, 1970].)
- MOORE, G. E. 1903. *Principia Ethica*. Cambridge: Cambridge University Press.
- MORGAN, ELAINE. 1982. *The Aquatic Ape*. London: Souvenir.
- . 1990. *The Scars of Evolution: What Our Bodies Tell Us About Human Origins*. London: Souvenir.
- MUIR, JOHN. 1972. *Original Sanscrit Texts and the Origin and History of the People of India, Their Religion and Institutions*. Delhi: Oriental. Originally published 1868–73, London: Trubner.
- MURRAY, JAMES D. 1989. *Mathematical Biology*. New York: Springer-Verlag.
- NEHAMAS, ALEXANDER. 1980. "The Eternal Recurrence." *Philosophical Review*, vol. 89, pp. 331–56.
- NEUGEBAUER, OTTO. 1989. "A Babylonian Lunar Ephemeris from Roman Egypt." In E. Leichtz, M. de J. Ellis, and P. Gerardi, eds., *A Scientific Humanist: Studies in Honor of Abraham Sachs* (Philadelphia: The University Museum [Distributed by the Samuel North Kramer Fund]), pp. 301–4.
- NEWELL, ALLEN, and SIMON, HERBERT. 1956. "The Logic Theory Machine." *IRE Transactions on Information Theory IT-2(3)*, pp. 61–79.
- . 1964. "GPS: A Program That Simulates Human Thought." In Feigenbaum and Feldman 1964.
- NEWTON, ISAAC. 1726. *Philosophiæ Naturalis Principia Mathematica*.
- NIETZSCHE, FRIEDRICH. 1881. *Daybreak: Thoughts on the Prejudices of Morality*. (Trans. R. J. Hollingdale [Cambridge: Cambridge University Press, 1982].)
- . 1882. *Die fröhliche Wissenschaft (The Gay Science)*. (Trans. Walter Kaufmann [New York: Vintage, 1974].)
- . 1885. *Beyond Good and Evil*. (Trans. Walter Kaufmann [New York: Vintage, 1966].)

- . 1887. *On the Genealogy of Morals*. (Trans. Walter Kaufmann [New York: Vintage, 1967].)
- . 1889. *Ecce Homo*. (Trans. Walter Kaufmann [New York: Vintage, 1968].)
- . 1901. *The Will to Power*. (Trans. Walter Kaufmann and R. J. Hollingdale [New York: Vintage, 1968].)
- NOWAK, MARTIN, and SIMUND, KARL. 1993. "A Strategy of Win-Stay, Lose-Shift That Outperforms Tit-for-Tat in the Prisoner's Dilemma Game." *Nature*, vol. 364, pp. 56–58.
- NOZICK, ROBERT. 1981. *Philosophical Explanation*. Cambridge, Mass.: Belknap/Harvard University Press.
- O'NEILL, ONORA. 1980. "The Perplexities of Famine Relief." In Tom Regan, ed., *Matters of Life and Death* (New York: Random House), pp. 26–48.
- . 1986. *Faces of Hunger*. Boston: Allen & Unwin, 1986.
- ORGEL, LESLIE E., and CRICK, FRANCIS. 1980. "Selfish DNA: The Ultimate Parasite." *Nature*, vol. 284, pp. 604–607.
- OTERO, CARLOS P. 1990. "The Emergence of *Homo Loquens* and the Laws of Physics." *Behavioral and Brain Sciences*, vol. 13, pp. 747–50.
- PAGELS, HEINZ. 1985. "A Cozy Cosmology." *The Sciences*, March/April, pp. 34–39.
- . 1988. *The Dreams of Reason: The Computer and the Rise of the Sciences of Complexity*. New York: Simon & Schuster.
- PALEY, WILLIAM. 1803. *Natural Theology: or, Evidences of the Existence and Attributes of the Deity, Collected from the Appearances of Nature*. 5th ed. London: Faulder.
- PAPERT, SEYMOUR. 1980. *Mindstorms: Children, Computers and Powerful Ideas*. New York: Basic Books.
- . 1993. *The Children's Machine: Rethinking School in the Age of the Computer*. New York: Basic Books.
- PAPINEAU, DAVID. 1987. *Reality and Representation*. Oxford: Blackwell.
- PARFIT, DEREK. 1984. *Reasons and Persons*. Oxford: Clarendon.
- PARSONS, WILLIAM BARCLAY. 1939. *Engineers and Engineering in the Renaissance*. Reprint ed., Cambridge, Mass: MIT Press, 1967.
- PEACOCKE, CRISTOPHER. 1992. *A Study of Concepts*. Cambridge, Mass.: MIT Press.
- PECKHAM, MORSE, ed. 1959. *The Origin of Species by Charles Darwin: A Variorum Text*. Pittsburgh: University of Pennsylvania Press.
- PENROSE, ROGER. 1989. *The Emperor's New Mind Concerning Computers, Minds, and the Laws of Physics*. Oxford: Oxford University Press.
- . 1990. "The Nonalgorithmic Mind." *Behavioral and Brain Sciences*, vol. 13, pp. 692–705
- . 1991. "Setting the Scene: The Claim and the Issues." Wolfson Lecture, January 15.
- . 1993. "Nature's Biggest Secret" (review of Weinberg 1992). *New York Review of Books*, October 21, pp. 78–82.

- PIATELLI-PALMARINI, MASSIMO. 1989. "Evolution, Selection, and Cognition: From 'Learning' to Parameter Setting in Biology and the Study of Language." *Cognition*, vol. 31, pp. 1-44.
- PINKER, STEVEN. 1994. *The Language Instinct*. New York: Morrow.
- PINKER, STEVEN, and BLOOM, PAUL. 1990. "Natural Language and Natural Selection." *Behavioral and Brain Sciences*, vol. 13, pp. 707-84.
- PITTENDRIGH, COLIN. 1958. "Adaptation, Natural Selection, and Behavior." In A. Roe and G. G. Simpson, eds., *Behavior and Evolution* (New Haven: Yale University Press), pp. 390-416.
- POE, EDGAR ALLAN. 1836. "Maelzel's Chess-Player." *Southern Literary Messenger*. Reprinted in Edgar Allan Poe, *Edgar Allan Poe: Essays and Reviews* (New York: Library of America, 1984), pp. 1253-76.
- . 1836b. *Southern Literary Messenger*, suppl., July 1836. Reprinted in J. M. Walker, ed., *Edgar Allan Poe: The Critical Heritage* (New York: Routledge & Kegan Paul, 1986), pp. 89-90.
- POPPER, KARL, and ECCLES, JOHN. 1977. *The Self and Its Brain*. Berlin, London: Springer-Verlag.
- POUNDSTONE, WILLIAM. 1985. *The Recursive Universe: Cosmic Complexity and the Limits of Scientific Knowledge*. New York: Morrow.
- . 1992. *Prisoner's Dilemma: John von Neumann, Game Theory, and the Puzzle of the Bomb*. New York: Doubleday Anchor.
- PREMACK, DAVID. 1986. *Gavagai! Or the Future History of the Animal Language Controversy*. Cambridge, Mass.: MIT Press.
- PUTNAM, HILARY. 1975. *Mind, Language and Reality*. Philosophical Papers, vol. II. Cambridge: Cambridge University Press.
- . 1987. *The Faces of Realism*. LaSalle, Ill.: Open Court.
- QUINE, W. V. O. 1953. "On What There Is." In *From a Logical Point of View* (Cambridge, Mass.: Harvard University Press), pp. 1-19.
- . 1960. *Word and Object*. Cambridge, Mass.: Harvard University Press.
- . 1969. "Natural Kinds." In *Ontological Relativity* (New York: Columbia University Press), pp. 114-38.
- . 1987. *Quiddities: An Intermittently Philosophical Dictionary*. Cambridge, Mass.: Harvard University Press.
- RACHELS, JAMES. 1991. *Created from Animals: The Moral Implications of Darwinism*. Oxford: Oxford University Press.
- RAWLS, JOHN. 1971. *A Theory of Justice*. Cambridge, Mass.: Harvard University Press.
- RAY, THOMAS S. 1992. "An Approach to the Synthesis of Life." In C. G. Langton, C. Taylor, J. D. Farmer, and S. Rasmussen, eds., *Artificial Life II* (Redwood City, Calif.: Addison-Wesley), pp. 371-408.
- RAYMO, CHET. 1988. "Mysterious Sleep." *Boston Globe*, September 19.
- RAYMOND, ERIC S. 1993. *The New Hacker's Dictionary*. Cambridge, Mass.: MIT Press.
- RÉE, PAUL. 1877. *Origin of the Moral Sensations*. (*Der Ursprung der Moralischen Empfindungen* [Chemnitz: E. Schmeitzner].)

- RICHARD, MARK. 1992. *Propositional Attitudes*. Cambridge: Cambridge University Press.
- RICHARDS, GRAHAM. 1991. "The Refutation That Never Was: The Reception of the Aquatic Ape Theory, 1972–1987." In Roede et al. 1991, pp. 115–26.
- RICHARDS, ROBERT J. 1987. *Darwin and the Emergence of Evolutionary Theories of Mind and Behavior*. Chicago: University of Chicago Press.
- RIDLEY, MARK. 1985. *The Problems of Evolution*. Oxford: Oxford University Press.
- . 1993. *Evolution*. Boston: Blackwell.
- RIDLEY, MAIT. 1993. *The Red Queen: Sex and the Evolution of Human Nature*. New York: Macmillan.
- ROBB, CHRISTINA. 1991. "How & Why" *Boston Globe*, August 5, p. 38.
- ROBBINS, TOM. 1976. *Even Cowgirls Get the Blues*. New York: Bantam.
- ROEDE, MACHTELD; WIND, JAN; PATRICK, JOHN M.; and REYNOLDS, VERNON, eds. 1991. *The Aquatic Ape: Fact or Fiction*. London: Souvenir.
- ROSENBLATT, FRANK. 1962. *Principles of Neurodynamics*. New York: Spartan.
- ROUSSEAU, JEAN-JACQUES. 1755. *Discourse on the Origin and Foundations of Inequality Among Men*. Amsterdam: Ray.
- RUMELHART, D. 1989. "The Architecture of Mind: A Connectionist Approach." In M. Posner, ed., *Foundations of Cognitive Science* (Cambridge, Mass.: MIT Press), pp. 133–59.
- RUSE, MICHAEL. 1985. *Sociobiology: Sense or Nonsense?* 2nd ed. Dordrecht: Reidel.
- , ed. 1989. *Philosophy of Biology*. London: Macmillan.
- RUSE, MICHAEL, and WILSON, EDWARD O. 1985. "The Evolution of Ethics." *New Scientist*, vol. 17, October, pp. 50–52. Reprinted in Ruse 1989.
- RUSHDIE, SALMAN. 1994. "Born in Bombay" (letter). *London Review of Books*, April 7, p. 4. (See also Arab and Muslim Writers, 1994.)
- RUSSELL, BERTRAND. 1945. *A History of Western Philosophy*. New York: Simon & Schuster.
- RUTHEN, RUSSELL. 1993. "Adapting to Complexity." *Scientific American*, January, p. 138.
- SAMUEL, A. L. 1964. "Some Studies in Machine Learning Using the Game of Checkers." Reprinted in Feigenbaum and Feldman 1964, pp. 71–105. Originally published in *IBM Journal of Research and Development*, July 1959, vol. 3, pp. 211–29.
- SCHELLING, THOMAS. 1960. *The Strategy of Conflict*. Cambridge, Mass.: Harvard University Press.
- SCHIFFER, STEPHEN. 1987. *Remnants of Meaning*. Cambridge, Mass.: MIT Press.
- SCHOPF, J. WILLIAM. 1993. "Microfossils of the Early Archean Apex Chert: New Evidence of the Antiquity of Life." *Science*, vol. 260, pp. 640–46.
- SCHRÖDINGER, ERNST. 1967. *What Is Life?* Cambridge: Cambridge University Press.
- SCHULL, JONATHAN. 1990. "Are Species Intelligent?" *Behavioral and Brain Sciences*, vol. 13, pp. 63–108.
- SEARLE, JOHN. 1980. "Minds, Brains and Programs." *Behavioral and Brain Sciences*, vol. 3, pp. 417–58.

- . 1985. *Minds, Brains and Science*. Cambridge, Mass.: Harvard University Press.
- . 1992. *The Rediscovery of the Mind*. Cambridge, Mass.: MIT Press.
- SELLARS, WILFRID. 1963. *Science, Perception and Reality*. London: Routledge & Kegan Paul.
- SELZER, JACK. ed. 1993. *Understanding Scientific Prose*. Madison, Wisc.: University of Wisconsin Press.
- SHEA, B. T. 1977. "Eskimo Cranofacial Morphology, Cold Stress and the Maxillary Sinus." *American Journal of Physical Anthropology*, vol. 47, pp. 289–300.
- SHERMAN, PAUL W.; JARVIS, JENNIFER U. M.; and ALEXANDER, RICHARD D. 1991. *The Biology of the Naked Mole-Rat*. Princeton: Princeton University Press.
- SHIELDS, W. M., and SHIELDS, L. M. 1983. "Forcible Rape: An Evolutionary Perspective." *Ethology and Sociobiology*, vol. 4, pp. 115–36.
- SIBLEY, C. G., and AHLQUIST, J. E. 1984. "The Phylogeny of the Hominoid Primates, as Indicated by DNA-DNA Hybridization." *Journal of Molecular Evolution*, vol. 20, pp. 2–15.
- SIGMUND, KARL. 1993. *Games of Life: Explorations in Ecology, Evolution, and Behaviour*. Oxford: Oxford University Press.
- SILLS, DAVID L., and ROBERT K. MERTON, eds. 1991. *The Macmillan Book of Social Science Quotations*. New York: Macmillan.
- SIMON, HERBERT. 1957. *Models of Man*. New York: Wiley.
- . 1959. "Theories of Decision-Making in Economics and Behavioral Science." *American Economic Review*, vol. 49, pp. 253–83.
- . 1969. *The Sciences of the Artificial*. Cambridge, Mass.: MIT Press.
- SIMON, HERBERT A., and KAPLAN, CRAIG. 1989. "Foundations of Cognitive Science." In M. Posner, ed., *Foundations of Cognitive Science* (Cambridge, Mass.: MIT Press), pp. 1–47.
- SIMON, HERBERT, and NEWELL, ALLEN. 1958. "Heuristic Problem Solving: The Next Advance in Operations Research." *Operations Research*, vol. 6, pp. 1–10.
- SINGER, PETER. 1981. *The Expanding Circle: Ethics and Sociobiology*. Oxford: Clarendon.
- SKINNER, B. F. 1953. *Science and Human Behavior*. New York: Macmillan.
- . 1957. *Verbal Behavior*. New York: Appleton-Century-Crofts.
- . 1971. *Beyond Freedom and Dignity*. New York: Knopf.
- SKYRMS, BRIAN, 1993. "Justice and Commitment" (preprint).
- . 1994a. "Sex and Justice." *Journal of Philosophy*, vol. 91, pp. 305–20.
- . 1994b. "Darwin Meets *The Logic of Decision*: Correlation in Evolutionary Game Theory." *Philosophy of Science*, December, pp. 503–28.
- SMOLENSKY, PAUL. 1983. "On the Proper Treatment of Connectionism." *Behavioral and Brain Sciences*, vol. 11, pp. 1–74.
- SMOLIN, LEE. 1992. "Did the Universe Evolve?" *Classical and Quantum Gravity*, vol. 9, pp. 173–91.
- SNOW, C. P. 1963. *The Two Cultures, and a Second Look*. Cambridge: Cambridge University Press.

- SOBER, ELLIOT. 1981a. "Holism, Individualism, and Units of Selection." *PSA 1980* (Philosophy of Science Association), vol. 2, pp. 93–121.
- . 1981b. "The Evolution of Rationality." *Synthese*, vol. 46, pp. 95–120.
- . 1984a. *The Nature of Selection: Evolutionary Theory in Philosophical Focus*. Cambridge, Mass.: MIT Press.
- . ed., 1984b. *Conceptual Issues in Evolutionary Biology*. Cambridge, Mass.: MIT Press.
- . 1988. *Reconstructing the Past*. Cambridge, Mass.: MIT Press.
- , ed. 1994. *Conceptual Issues in Evolutionary Biology*. 2nd ed. Cambridge, Mass.: MIT Press.
- SPENCER, HERBERT. 1870. *The Principles of Psychology*. 2nd ed. London: Williams & Norgate.
- SPERBER, DAN. 1985. "Anthropology and Psychology: Towards an Epidemiology of Representations." *Man*, vol. 20, pp. 73–89.
- . 1990. "The Epidemiology of Beliefs." In C. Fraser and G. Gaskell, eds., *The Social Psychological Study of Widespread Beliefs* (Oxford: Clarendon), pp. 25–44.
- . In press. "The Modularity of Thought and the Epidemiology of Representations." In Lawrence A. Hirschfeld and Susan A. Gelman, eds., *Mapping the Mind: Domain Specificity in Cognition and Culture* (Cambridge: Cambridge University Press).
- SPERBER, DAN, and WILSON, DEIRDRE. 1986. *Relevance: A Theory of Communication*. Cambridge, Mass.: Harvard University Press.
- STANLEY, STEVEN M. 1981. *The New Evolutionary Timetable: Fossils, Genes, and the Origin of Species*. New York: Basic Books.
- STERELNY, KIM. 1988. Review of Dawkins 1986a. *Australasian Journal of Philosophy*, vol. 66, pp. 421–26.
- . 1992. "Punctuated Equilibrium and Macroevolution." In P. Griffiths, ed., *Trees of Life* (Norwell, Mass.: Kluwer), pp. 41–63.
- . 1994. Review of Ereshefsky, 1992, in *Philosophical Books*, vol. 35, pp. 9–29.
- STERELNY, K., and KITCHER, P. 1988. "The Return of the Gene." *Journal of Philosophy*, vol. 85, pp. 339–60.
- STETTER, KARL O.; HUBER, R.; BLOCHL, E.; KURR, M.; EDEN, R. D.; FIELDER, M.; CASH, H.; and VANCE, I. 1993. "Hyperthermophilic Archaea Are Thriving in Deep North Sea and Alaskan Oil Reservoirs." *Nature*, vol. 365, p. 743.
- STEWART, IAN, and GOLUBITSKY, MARTIN. 1992. *Fearful Symmetry: Is God a Geometer?* Oxford: Blackwell.
- STOVE, DAVID. 1992. "A New Religion." *Philosophy*, vol. 27, pp. 233–40.
- STRAWSON, P. F. 1962. "Freedom and Resentment." *Proceedings of the British Academy*, vol. 48, pp. 118–39.
- STURGEON, NICHOLAS. 1985. "Moral Judgment and Norms." *Ethics*, vol. 96, pp. 5–41.
- SYMONS, DONALD. 1983. "FLOAT: A New Paradigm for Human Evolution." In

- George M. Scherr, ed., *The Best of the Journal of Irreproducible Results* (New York: Workman).
- . 1992. "On the Use and Misuse of Darwinism in the Study of Human Behavior." In Barkow, Cosmides, and Tooby 1992, pp. 137–62.
- TAIT, P. G. 1880. "Prof. Tait on the Formula of Evolution." *Nature*, vol. 23, pp. 80–82.
- TEILHARD DE CHARDIN, PIERRE. 1959. *The Phenomenon of Man*. New York: Harper Brothers.
- THOMPSON, D'ARCY W. 1917. *On Growth and Form*. Cambridge: Cambridge University Press.
- TOOBY, JOHN, and COSMIDES, LEDA. 1992. "The Psychological Foundations of Culture." In Barkow, Cosmides, and Tooby 1992, pp. 19–136.
- TRIVERS, ROBERT. 1971. "The Evolution of Reciprocal Altruism." *Quarterly Review of Biology*, vol. 4, pp. 35–57.
- . 1972. "Parental Investment and Sexual Selection." In B. Campbell, ed., *Sexual Selection and the Descent of Man* (Chicago: Aldine), pp. 136–79.
- . 1985. *Social Evolution*. Menlo Park, Calif.: Benjamin/Cummings.
- TUDGE, COLIN. 1993. "Taking the Pulse of Evolution," *New Scientist*, July 24, pp. 32–36.
- TURING, ALAN. 1946. *ACE Reports of 1946 and Other Papers*. Ed. B. E. Carpenter and R. W. Doran. Cambridge, Mass.: MIT Press.
- . 1950. "Computing Machinery and Intelligence." *Mind*, vol. 59, pp. 433–60.
- . 1952. "The Chemical Basis of Morphogenesis." *Philosophical Transactions of the Royal Society of London*, vol. B237, pp. 37–72.
- TURNBULL, COLIN. 1972. *The Mountain People*. New York: Simon & Schuster.
- ULAM, STANISLAW. 1976. *Adventures of a Mathematician*. New York: Scribner's.
- UNGER, PETER. 1990. *Identity, Consciousness and Value*. New York: Oxford University Press.
- UTTLEY, A. M. 1979. *Information Transmission in the Nervous System*. London: Academic.
- VAN INWAGEN, PETER. 1993a. *Metaphysics*. Oxford: Oxford University Press.
- . 1993b. "Critical Study" (of Unger 1990). *Nous*, vol. 27, pp. 373–39.
- VERMEIJ, GEERAT J. 1987. *Evolution and Escalation*. Princeton: Princeton University Press.
- VON FRISCH, K. 1967. *A Biologist Remembers*. Oxford: Pergamon.
- VON NEUMANN, JOHN. 1966. *Theory of Self-reproducing Automata*. Posthumously ed. Arthur Burks. Champaign-Urbana: University of Illinois Press.
- VON NEUMANN, JOHN, and MORGENSTERN, OSKAR. 1944. *Theory of Games and Economic Behavior*. Princeton: Princeton University Press.
- VRBA, ELIZABETH. 1985. "Environment and Evolution: Alternative Causes of Temporal Distribution of Evolutionary Events." *Suid-Afrikaanse Tydskrif Wetens*, vol. 81, pp. 229–36.

- WANG, HAO. 1974. *From Mathematics to Philosophy*. London: Routledge & Kegan Paul.
- . 1993. "On Physicalism and Algorithmism." *Philosophia Mathematica*, Series 3, vol. 1, pp. 97–138.
- WASON, PETER. 1969. "Regression in Reasoning." *British Journal of Psychology*, vol. 60, pp. 471–80.
- WATERS, C. KENNETH. 1990. "Why the Antireductionist Consensus Won't Survive the Case of Classical Mendelian Genetics." *PSA 1990 (Philosophy of Science Association)*, vol. 1, pp. 125–39. Reprinted in Sober 1994, pp. 401–17.
- WECHKIN, STANLEY; MASSERMAN, JULES H.; and TERRIS, WILLIAM. 1964. "Shock to a Con-specific as an Aversive Stimulus." *Psychonomic Science*, vol. 1, pp. 47–48.
- WEINBERG, STEVEN. 1992. *Dreams of a Final Theory*. New York: Pantheon.
- WEISMANN, AUGUST. 1893. *The Germ Plasm: A Theory of Heredity*. English trans. London: Scott.
- WERTHEIMER, ROGER. 1974. "Philosophy on Humanity." In R. L. Perkins, ed., *Abortion: Pro and Con* (Cambridge, Mass.: Schenkman).
- WHEELER, JOHN ARCHIBALD. 1974. "Beyond the End of Time." In Martin Rees, Remo Ruffini, and John Archibald Wheeler, *Black Holes, Gravitational Waves and Cosmology: An Introduction to Current Research* (New York: Gordon and Breach).
- WHITE, STEPHEN L. 1988. "Self-Deception and Responsibility for the Self." In B. McLaughlin and A. Rorty, eds., *Perspectives on Self-Deception* (Berkeley: University of California Press).
- . 1991. *The Unity of the Self*. Cambridge, Mass.: MIT Press.
- . "Constraints on an Evolutionary Explanation of Morality." Unpublished manuscript.
- WHITFIELD, PHILIP. 1993. *From So Simple a Beginning: The Book of Evolution*. New York: Macmillan.
- WILBERFORCE, SAMUEL. 1860. "Is Mr Darwin a Christian?" (review of *Origin*, published anonymously). *Quarterly Review*, vol. 108, July, pp. 225–64.
- WILLIAMS, BERNARD. 1973. "A Critique of Utilitarianism." In J. J. C. Smart and Bernard Williams, *Utilitarianism: For and Against* (Cambridge: Cambridge University Press), pp. 77–150.
- . 1983. "Evolution, Ethics, and the Representation Problem." In D. S. Bendall, ed., *Evolution from Molecules to Men* (Cambridge: Cambridge University Press), pp. 555–66.
- . 1985. *Ethics and the Limits of Philosophy*. Cambridge, Mass.: Harvard University Press.
- WILLIAMS, GEORGE C. 1966. *Adaptation and Natural Selection*. Princeton: Princeton University Press.
- . 1985. "A Defense of Reductionism in Evolutionary Biology." *Oxford Surveys in Evolutionary Biology*, vol. 2, pp. 1–27.
- . 1988. "Huxley's Evolution and Ethics in Sociobiological Perspective." *Zygon*, vol. 23, pp. 383–407.

- . 1992. *Natural Selection: Domains, Levels, and Challenges*. Oxford: Oxford University Press.
- WILLIAMS, GEORGE C., and NESSE, RANDOLPH. 1991. "The Dawn of Darwinian Medicine." *Quarterly Review of Biology*, vol. 66, pp. 1–22.
- WILSON, DAVID SLOAN, and SOBER, ELLIOT. 1994. "Re-introducing Group Selection to the Human Behavior Sciences." *Behavioral and Brain Sciences*, vol. 17, pp. 585–608.
- WILSON, E. O. 1971. *The Insect Societies*. Cambridge, Mass.: Harvard University Press.
- . 1975. *Sociobiology: The New Synthesis*. Cambridge: Harvard University Press.
- . 1978. *On Human Nature*. Cambridge, Mass.: Harvard University Press.
- WIMSATT, WILLIAM. 1980. "Reductionist Research Strategies and Their Biases in the Unit of Selection Controversy." In T. Nickles, ed., *Scientific Discovery: Case Studies* (Hingham, Mass.: Kluwer), pp. 213–39.
- . 1981. "Units of Selection and the Structure of the Multi-Level Genome." In P. Asquith and R. Geire, eds., *PSA-1980* (Philosophy of Science Association), vol. 2, pp. 122–83.
- . 1986. "Developmental Constraints, Generative Entrenchment, and the Innate-acquired Distinction." In W. Bechtel, ed., *Integrating Scientific Disciplines* (Dordrecht: Martinus-Nijhoff), pp. 185–208.
- WIMSATT, WILLIAM, and BEARDSLEY, MONROE. "The Intentional Fallacy." In *The Verbal Icon: Studies in the Meaning of Poetry*. Lexington: University of Kentucky Press, 1954.
- WITTGENSTEIN, LUDWIG. 1922. *Tractatus Logico-philosophicus*. London: Routledge & Kegan Paul.
- WRIGHT, ROBERT. 1990. "The Intelligence Test" (review of Gould 1989a). *New Republic*, January 29, pp. 28–36.
- WRIGHT, SEWALL. 1931. "Evolution in Mendelian Populations." *Genetics*, vol. 16, p. 97.
- . 1932. "The Roles of Mutation, Inbreeding, Crossbreeding and Selection in Evolution." *Proceedings of the XI International Congress of Genetics*, vol. 1, pp. 356–66.
- . 1967. "Comments on the Preliminary Working Papers of Eden and Waddington." In P. S. Moorehead and M. M. Kaplan, eds., *Mathematical Challenges to the Neo-Darwinian Interpretation of Evolution*, Wistar Institute Symposia, monograph no. 5. Philadelphia: Wistar Institute Press.
- YOUNG, J. Z. 1965. *A Model of the Brain*. Oxford: Clarendon.
- ZAHAVI, A. 1987. "The Theory of Signal Selection and Some of Its Implications." In V. P. Delfino, ed., *International Symposium on Biological Evolution, Bari, 9–14 April 1985* (Bari, Italy: Adriatici Editrici), pp. 305–27.