



Overview of the Evolution of EN1999: Design of Aluminium Structures

22nd September 2020



Copyright © CEN, 2021. Reuse and reproduction of this document is authorised, provided the source is acknowledged as follows:
“reprinted with authorisation of CEN, copyright @CEN, rue de la Science 23, 1040 Brussels, Belgium”.

Structure of this slide deck

- General overview of the evolution of EN 1999
- Specific overview of the evolution of EN 1999 parts:
 - *1-1 General structural rules*
 - *1-2 Structural fire design*
 - *1-3 Structures susceptible to fatigue*
 - *1-4 Cold-formed structural sheeting*
 - *1-5 Shell Structures*

General overview of the Evolution of EN 1999: Design of Aluminium Structures

Agenda – Evolution of EN 1999

- Key changes to EN 1999
- New content included in the scope of EN 1999
- How ease of use has been enhanced

Complementary slides provide greater details for individual Eurocode Parts.

Key changes to EN 1999

GENERAL

- *According to the project for the new generation of Eurocode 9, all the new items were planned just for Part 1-1*
- *Anyway, important maintenance operations have been done for the other Parts 1-2, 1-3, 1-4 1-5, including upgrading, updating and simplifying, with some new additions where necessary*
- *Significant reduction of Nationally Determined Parameters has been done, from 89 to 49 (main clauses, all parts)*

Key changes to EN 1999

- *Introduction of additional structural typologies (bridging, roofing, composite aluminium-concrete)*
- *Introduction of new materials*
- *Introduction of a new buckling material class (Class B), intermediate between the previous classes*
- *Definition of improved buckling curves according to the new material classes (L/1000)*
- *Improvement of buckling curves (L/1000)*
- *Introduction of new connection types (Friction Stir Welding, bolt-channels, screw grooves)*

New content included in scope of EN1999

- *Special types of connections*
- *Bridges (Annex S)*
- *Lattice space roof structures (Annex T)*
- *Composite aluminium concrete beams (Annex U)*
- *Modified buckling conditions ($L/500$) (Annex V)*

How ease of use has been enhanced

- *Optimization of editorial layout and general improvement of wording*
- *Improvement of some figure*
- *The calculation methods have been simplified as far as possible*
- *Clear distinction between buckling of members with longitudinal welds and members with transverse welds*
- *Clear rules if the initial bow imperfection $L/1000$ for members is not fulfilled*
- *Reduction of NDPs*

Overview of the Evolution of EN 1999-1-1: General Structural Rules

Agenda – Evolution of EN 1999-1-1: general structural rules

- Key changes to EN 1999-1-1: general structural rules
- New content included in the scope of EN 1999-1-1: general structural rules
- How ease of use has been enhanced

Key changes to EN 1999-1-1

- *Introduction of new material, alloy EN-AW 5383*
- *Introduction of structural typologies (bridging, roofing, composite aluminium-concrete)*
- *Introduction of new buckling curves*
- *Introduction of new connection types (FSW, bolt-channels, screw grooves)*
- *Improvement and addendum of the rules for equivalent T-stub in tension*
- *Addition of out-of-plane loading on stiffened plating*

New content included in scope of EN 1999-1-1

- *New buckling curves*
- *Special types of connections (bolt-channel, screw-groove, friction-stir welding)*
- *Bridges (Annex S)*
- *Lattice space roof structures (Annex T)*
- *Composite aluminium concrete beams (Annex U)*
- *Modified buckling conditions (Annex V)*
- *Determining the extent of HAZ from hardness tests (Annex Q)*
- *Weld studs connected by arc stud welding with tip ignition (annex R)*

New buckling curves: values of α and $\bar{\lambda}_0$ for flexural buckling

Weld	Buckling class BC according to Table 5.3 and Table 5.4	Curve	α	$\bar{\lambda}_0$
Without weld	A	a	0,18	0,10
	B	b	0,30	0,15
	C	c	0,56	0,14
Longitudinal weld	A	aw	0,36	0,16
	B	<u>bw</u>	0,54	0,22
	C	<u>cw</u>	0,92	0,24

New buckling curves: reduction factor χ for flexural buckling

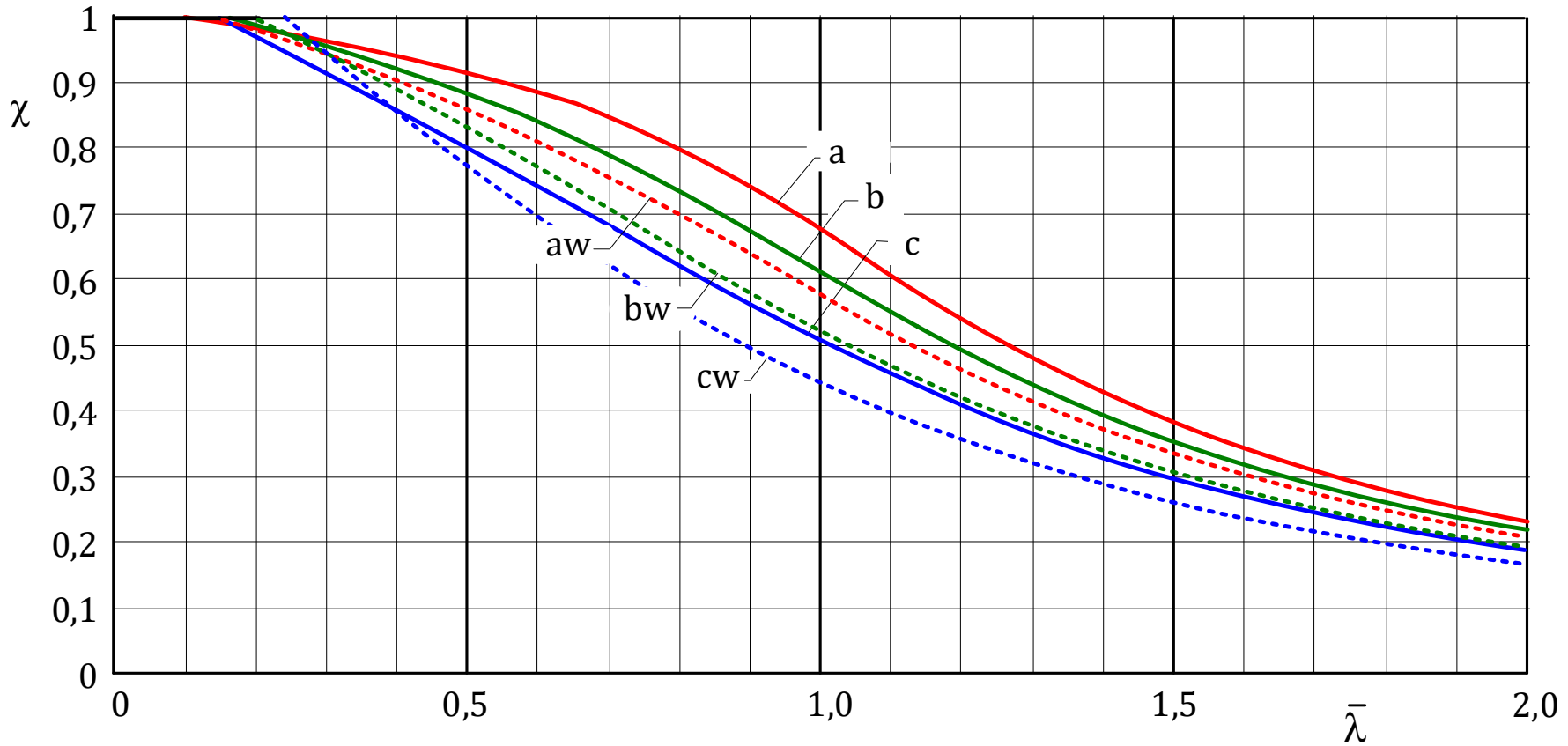

Equivalent T-stub

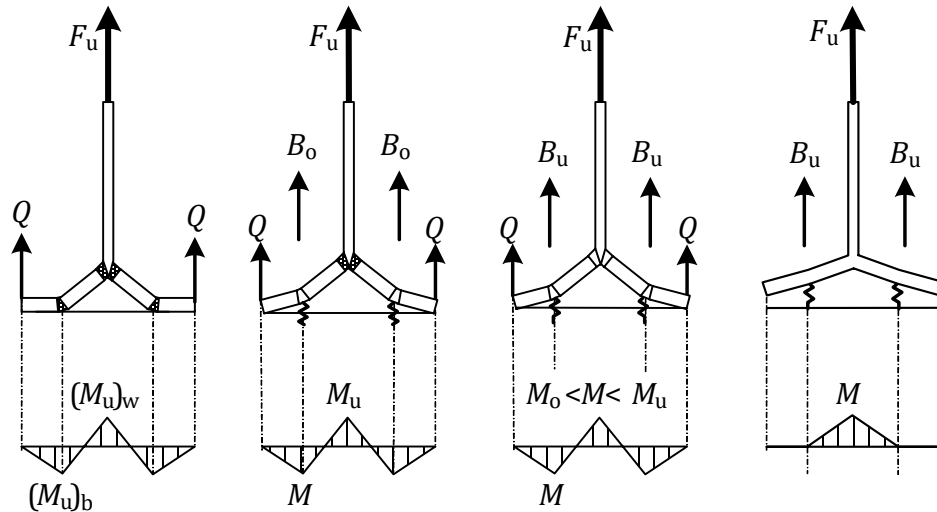

Failure modes of equivalent T-stub

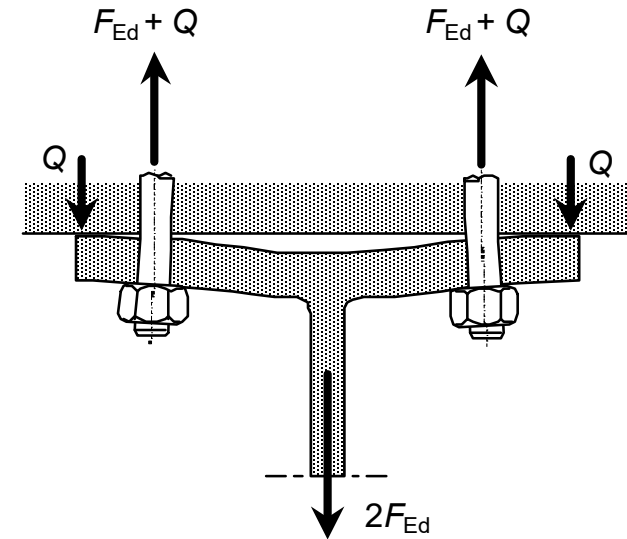
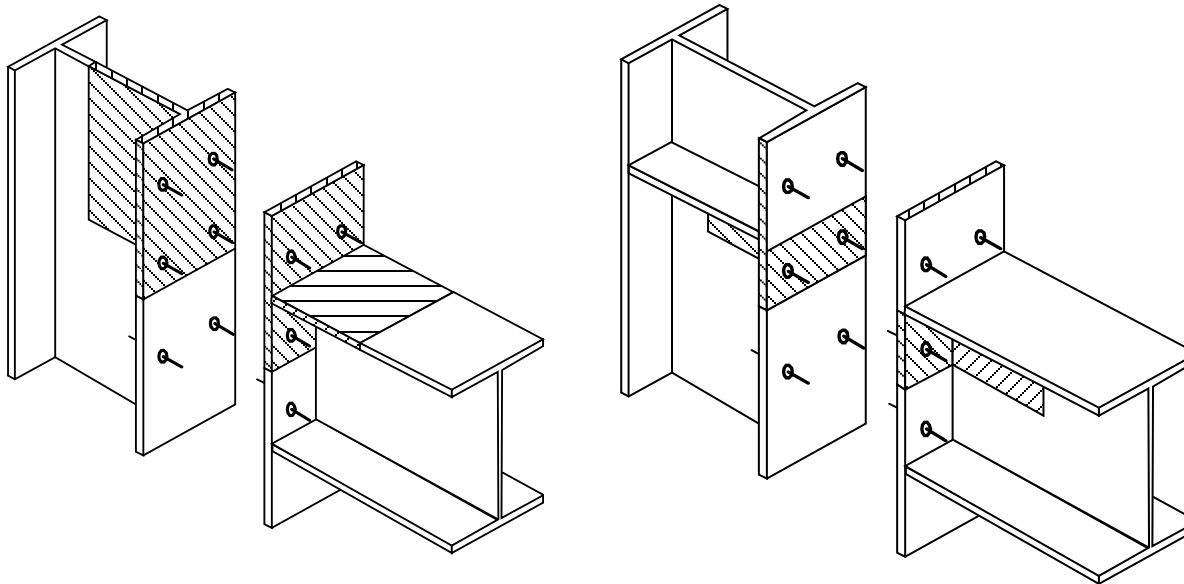

New connections types



Screw-groove

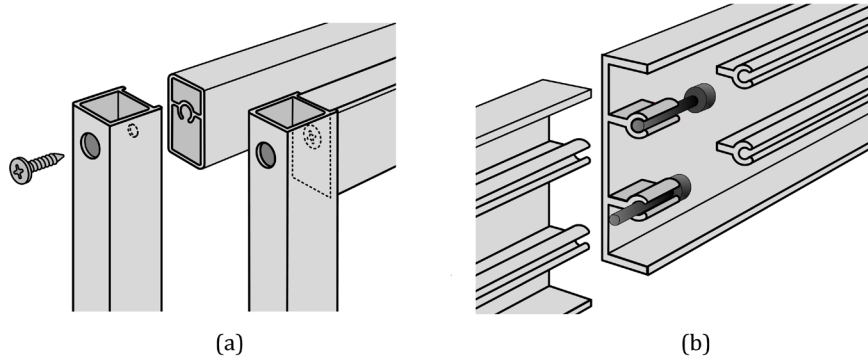

Bolt-channel

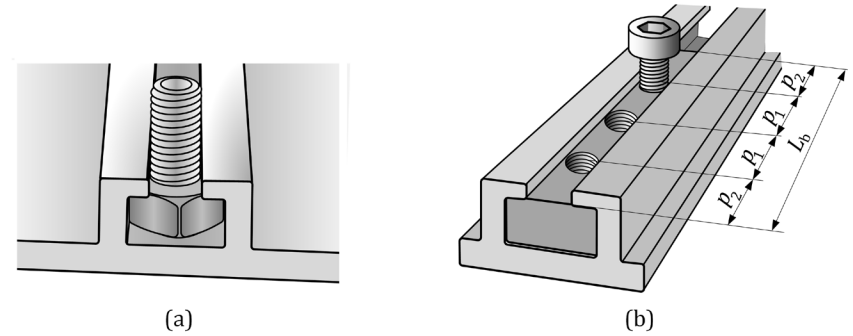

Friction Stir Weld, FSW

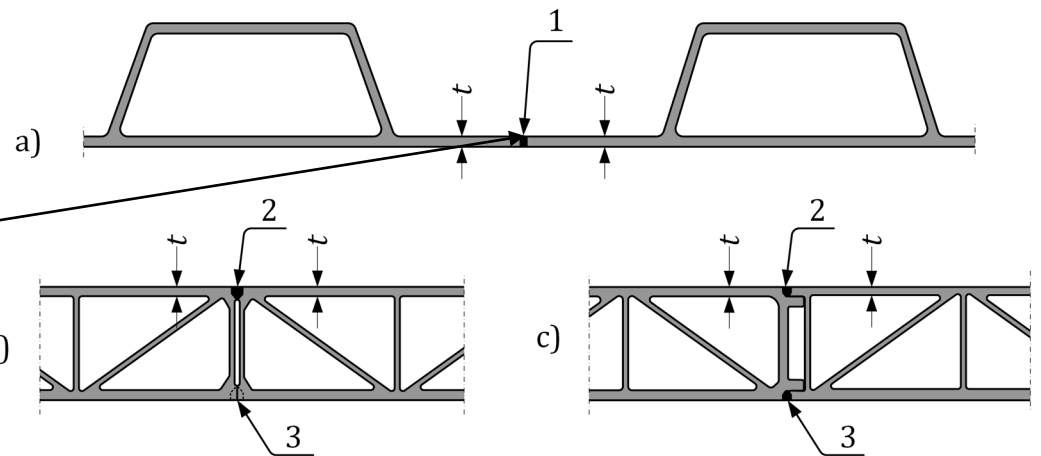
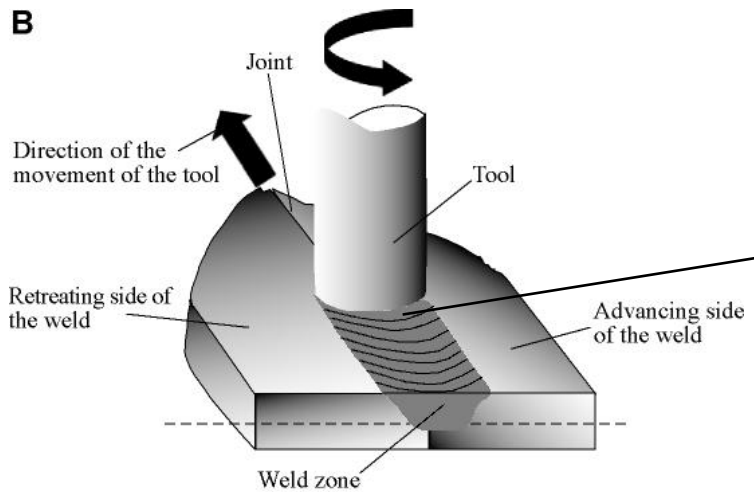

Details of aluminium decks

Extruded decks

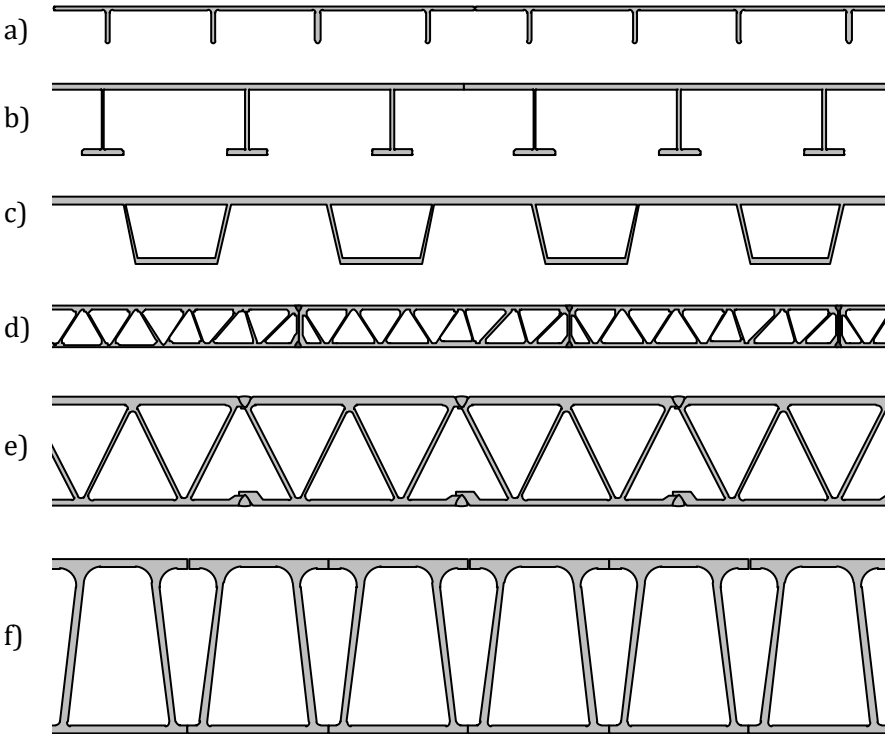

Deep girders

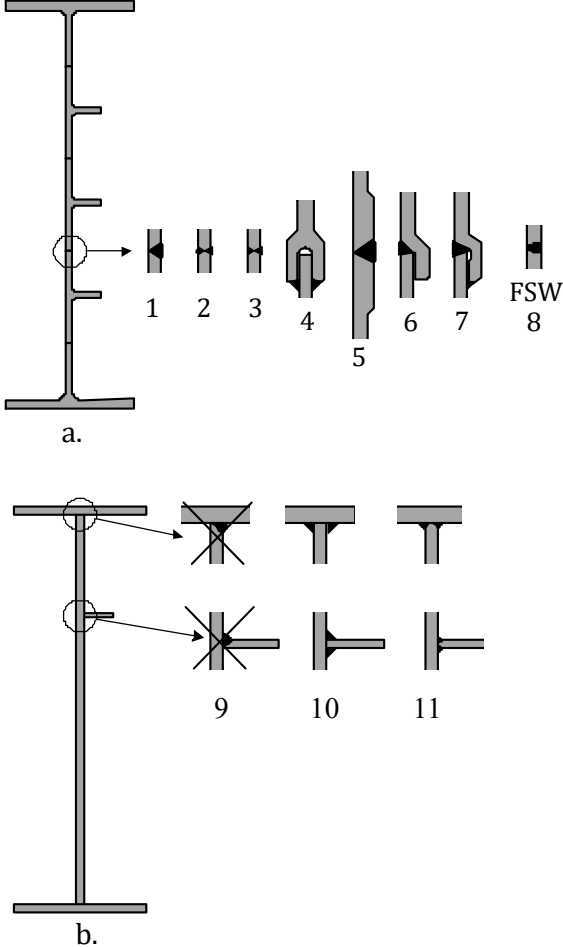

Details of aluminium briges

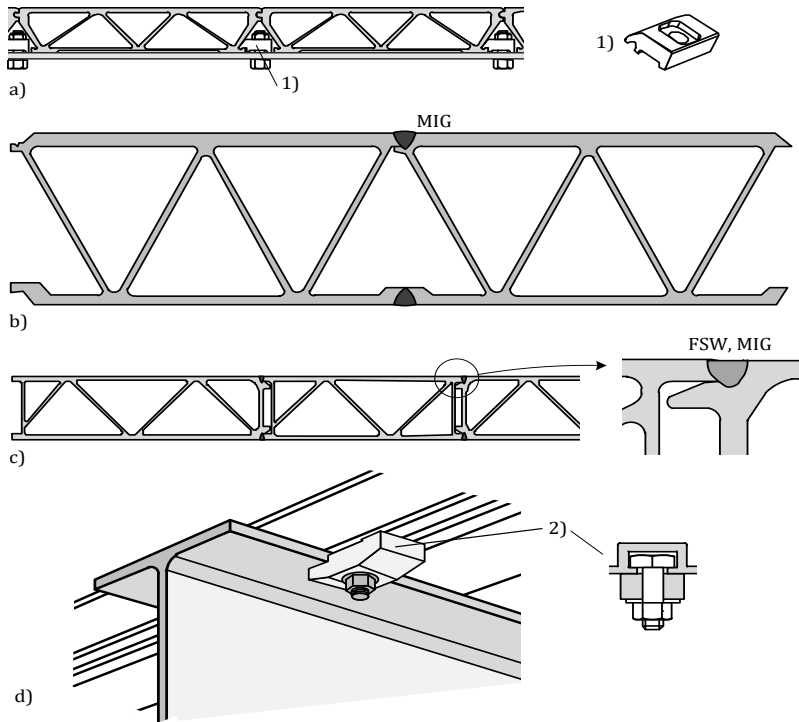

Details of splices of deck section

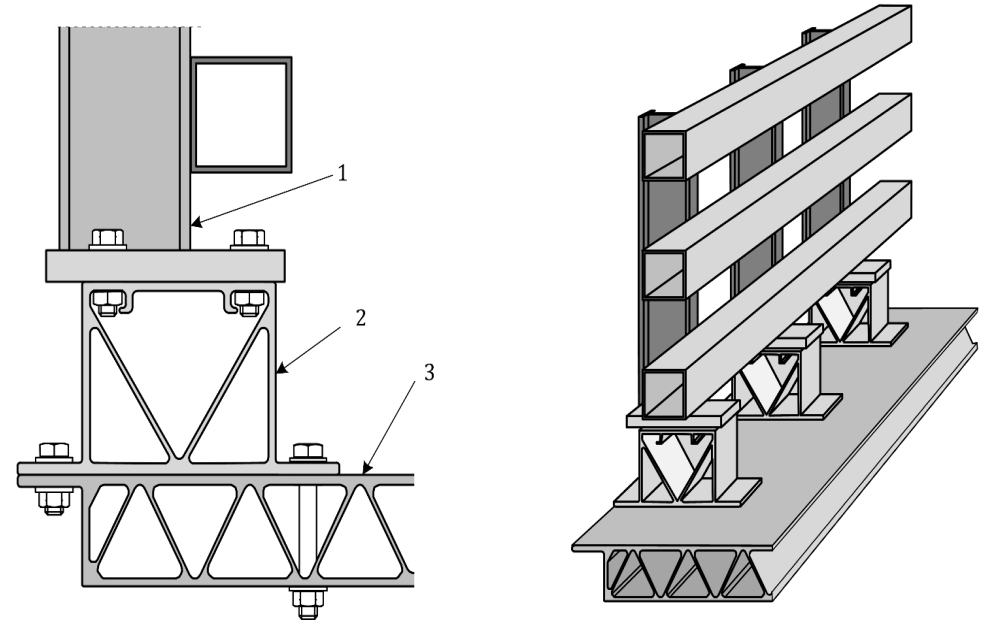

Connection of traffic barrier to aluminium deck

Lattice Spatial Roof Structures

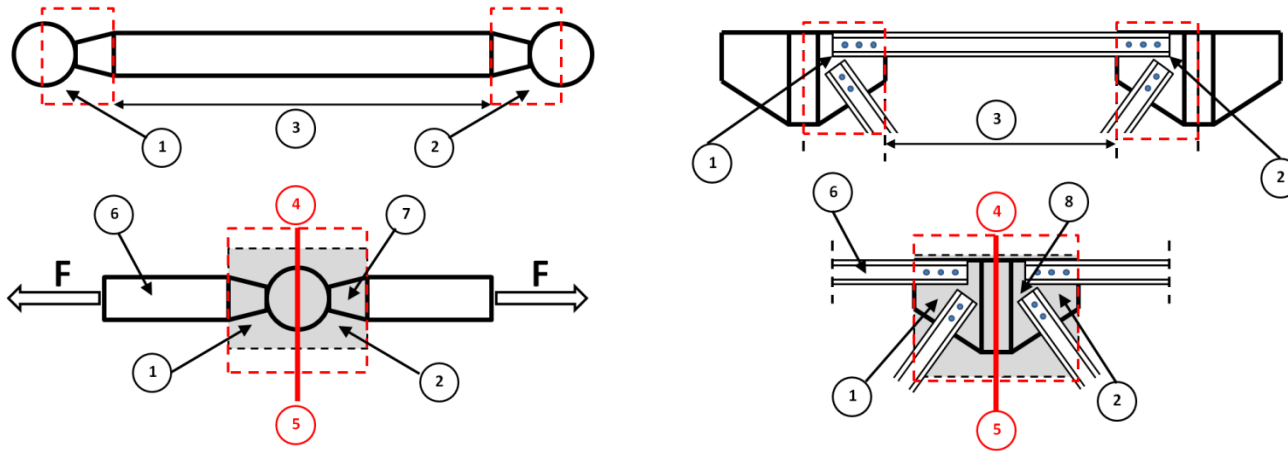

Definition of joint and connection

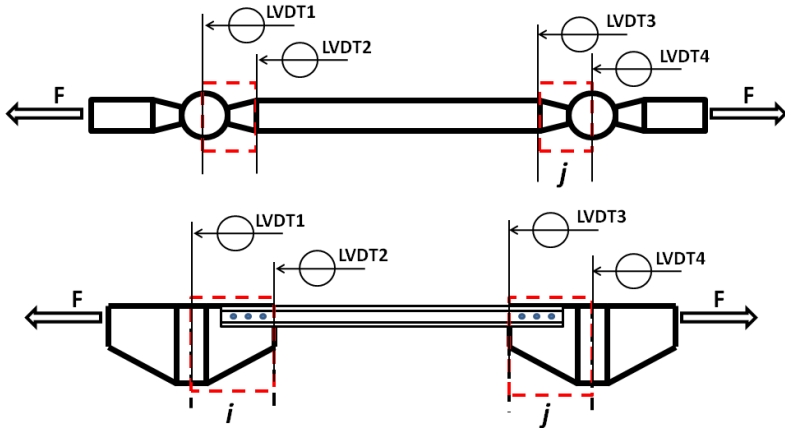

testing of a complete connection-to-member sub-assembly

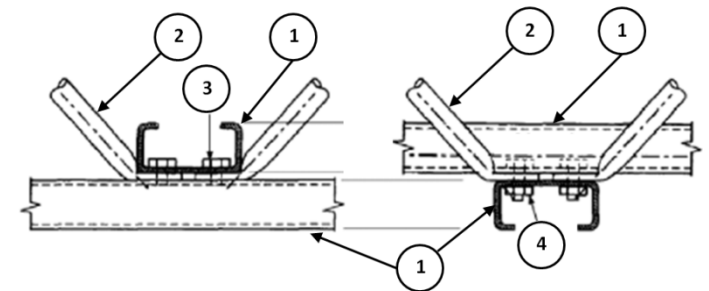
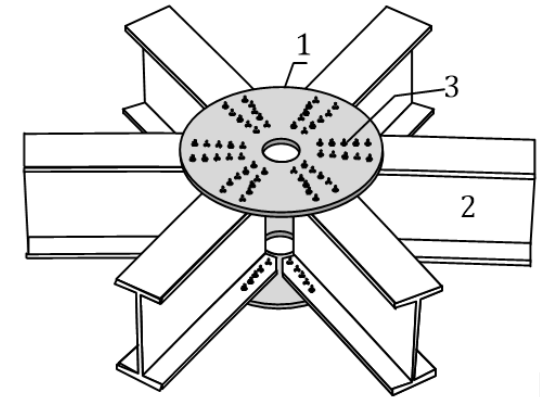

joints requiring the testing of a complete sub-assembly

Composite aluminium-concrete beams

Special types of connectors

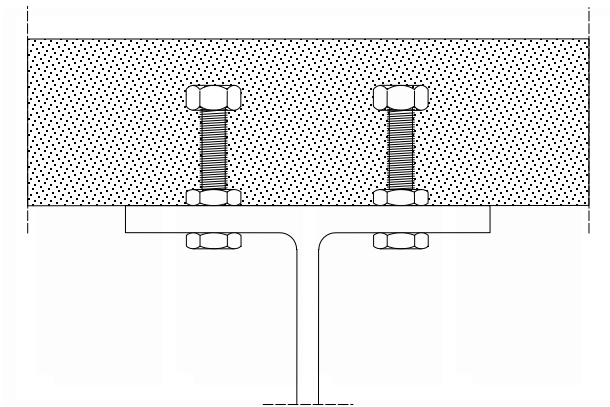

By bolts

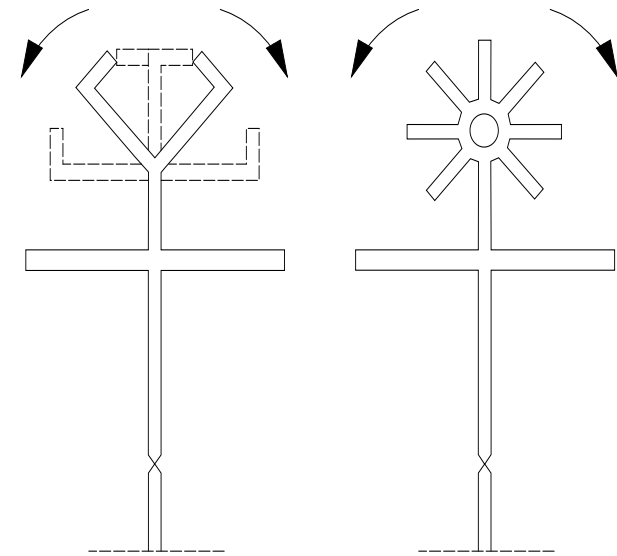

By extrusion

How ease of use has been enhanced

- *Optimization of editorial layout and general improvement of wording*
- *The calculation methods are simplified as far as possible*
- *E.g. clear distinction between buckling of members with longitudinal welds and members with transverse welds*

Overview of the Evolution of EN1999-1-2: Structural Fire Design



Agenda – Evolution of EN1999-1-2: *structural fire design*

- Key changes to EN1999-1-2: structural fire design
- New content included in the scope of EN1999-1-2: structural fire design
- How ease of use has been enhanced

Key changes to EN1999-1-2

→ *Light modifications with respect to the old version, which include:*

- *Some reorganization of the text and its coherence with other Eurocodes (EN199x-1-2 and EN1991)*
- *Improvement of some figures*
- *Updating of symbols*



New content included in scope of EN1999-1-2

→ *No significant modifications have been included in the content of EN1999-1-2*

How ease of use has been enhanced

- *Improved clarity and consistency*
- *Harmonisation of existing contents according to the new template provided by HGF (Horizontal Group Fire), which has been applied for the Fire Part of all Eurocodes (EN 199x-1-2)*
- Updating of many symbols according to Eurocodes related to other structural materials (EN 199x-1-2) and Eurocode 1



Overview of the Evolution of EN1999-1-3: structures susceptible to fatigue

Agenda – Evolution of EN1999-1-3: structures susceptible to fatigue

- Key changes to EN1999-1-3: structures susceptible to fatigue
- New content included in the scope of EN1999-1-3: structures susceptible to fatigue
- How ease of use has been enhanced

Key changes to EN1999-1-3

- *Not many changes introduced in this part;*
- *The changes mainly about improving clarity and scope:*
 - *Some reorganization of the text and its coherence with the general part EN1999-1-1*
 - *Improvement of some figures*
 - *Improvement of detail categories for fillet-welded joints between members (Table J.9)*
 - *Improvement of detail categories for bolted joints (Table J.15, see next page)*

Key changes to EN1999-1-3

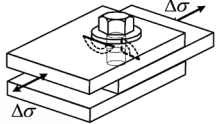
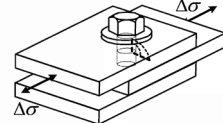
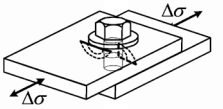
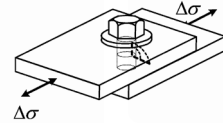
Detail type	Detail category $\Delta\sigma\text{-}m_1^d$	Constructional detail Initiation site	Stress analysis		Execution requirements
			Stress parameter	Stress concentrations already allowed for	
15.1	56-4	<p>Double covered symmetrical joint with preloaded (friction type), high strength steel bolt</p>  <p>In front of hole (sometimes at edge of hole)</p>	Nominal stress based on gross section properties	Surface texture, fastener hole geometry; unequal load distribution between rows of bolts; eccentricity of load path in symmetrical double covered lap joints only.	<p>Flat parallel surfaces</p> <p>Machining only by high-speed milling cutter; holes drilled (with optional reaming) or punched (with compulsory reaming if thickness > 6 mm)</p> <p>Class of preloaded bolts should be 8.8 or 10.9, see EN 1999-1-1.</p>
15.2	56-4	<p>Double covered symmetrical joint with fitted steel bolts</p>  <p>At edge of hole</p>	Nominal stress based on net section properties	Surface texture, fastener hole geometry; unequal load distribution between rows of bolts; eccentricity of load path in symmetrical double covered lap joints only.	<p>Flat parallel surfaces</p> <p>Machining only by high-speed milling cutter; holes drilled (with optional reaming) or punched (with compulsory reaming if thickness > 6 mm)</p> <p>For steel bolts, EN 1999-1-1.</p>
15.3	45-4	<p>One-sided connection with preloaded (friction type), high strength steel bolt</p>  <p>In front of hole (some-times at edge of hole)</p>	Nominal stress based on gross section properties	Surface texture, fastener hole geometry; unequal load distribution between rows of bolts.	<p>Flat parallel surfaces</p> <p>Machining only by high-speed milling cutter; holes drilled (with optional reaming) or punched (with compulsory reaming if thickness > 6 mm)</p> <p>Rotation of the joint under load should be prevented by structural means.</p> <p>Class of preloaded bolts should be 8.8 or 10.9, see EN 1999-1-1.</p>
15.4	40-4	<p>One-sided connection with fitted steel bolts</p>  <p>At edge of hole</p>	Nominal stress based on net section properties	Surface texture, fastener hole geometry; unequal load distribution between rows of bolts.	<p>Flat parallel surfaces</p> <p>Machining only by high-speed milling cutter; holes drilled (with optional reaming) or punched (with compulsory reaming if thickness > 6 mm)</p> <p>Rotation of the joint under load should be prevented by structural means.</p> <p>For steel bolts see EN 1999-1-1.</p>

^a Aluminium bolts should not be used in fatigue loaded structures.

New content included in scope of EN1999-1-3

→ *Inclusion of Friction Stir Welding*

- *Inclusion of Friction Stir Welding (FSW) in the scope*
- *Inclusion of detail categories for members with FSW (new Table J.17, see next slide)*

New content included in scope of EN1999-1-3

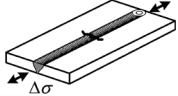
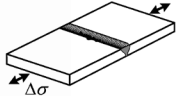
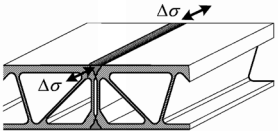
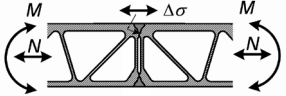
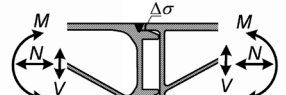
Detail type	Detail category $\Delta\sigma\text{-}m_1^a$	Constructional detail Initiation site Stress orientation	Weld type	Stress analysis		Execution requirements			
				Stress parameter	Stress concentrations already allowed for	Welding requirements	Quality level ^b		Additional
							Internal	Surface and geometric	
17.1	56-7	 <p>At weld surface or backing Stress due to longitudinal axial force</p>	Full penetration FSW	Nominal stress at initiation site	-	Continuous automatic welding	-	As welded, no start and stop at initiation site	
17.2	56-7	 <p>At weld surface or backing Stress due to transverse axial force</p>	Full penetration FSW	Nominal stress at initiation site	-	Continuous automatic welding	-	As welded, no start and stop at initiation site	
17.3	56-7	 <p>At weld toe or weld surface Stress due to longitudinal bending, axial and/or shear force on profiles</p>	Continuous FSW, no backing	Nominal stress based on weld depth	-	Continuous automatic welding	-	As welded, no start and stop at initiation site	
17.4	45-4,3	 <p>At weld toe Stress due to transverse bending, axial and/or shear force on profiles</p>	Continuous FSW, no backing	Nominal stress based on weld depth	-	Continuous automatic welding	-	As welded, no start and stop at initiation site	-
17.5	32-4,3	 <p>At weld toe Stress due to transverse bending, axial and/or shear force on profiles</p>	Continuous FSW, no backing	Nominal stress based on material thickness	-	Continuous automatic welding	-	As welded, no start and stop at initiation site	-

How ease of use has been enhanced

- *Some reorganization of the text and its coherence with the general part EN1999-1-1*
- *Improvement of some figures*



Overview of the Evolution of EN1999-1-4: Cold-formed Structural Sheeting

Agenda – Evolution of EN1999-1-4: cold-formed structural sheeting

- Key changes to Evolution of EN1999-1-4: cold-formed structural sheeting
- New content included in the scope of Evolution of EN1999-1-4: cold-formed structural sheeting
- How ease of use has been enhanced

Key changes to EN1999-1-4

- *Addition of general rules for cold-formed profiles*
- *Otherwise as few changes as possible, only improvement of text*



New content included in scope of EN1999-1-4

- *New general rules for cold-formed profiles (not only profiled sheeting)*

New content included in scope of EN1999-1-4

- *New general rules for cold-formed profiles (not only profiled sheeting)*
- *New rules for static overlapping system of sheeting with single or double overlap*
- *New rules for trapezoidal sheeting with side overlaps*

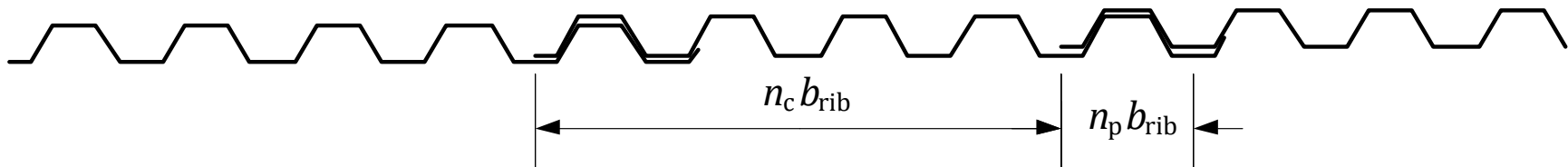
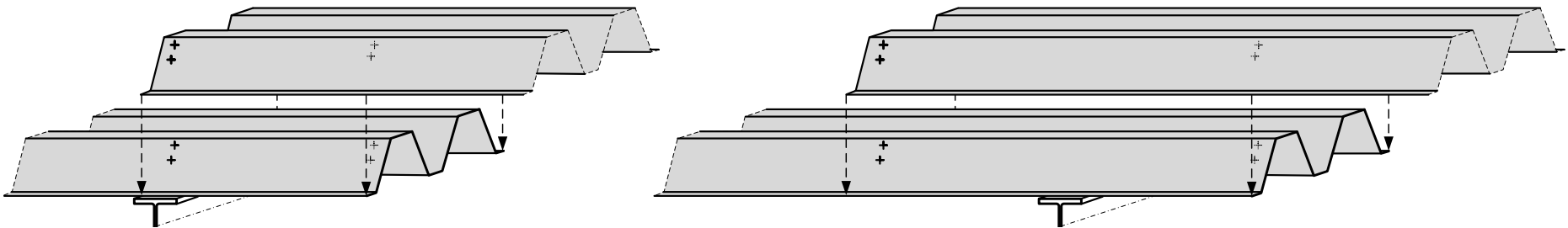

New content included in scope of EN1999-1-4

→ Clarification of behavior of diaphragm at the end of building

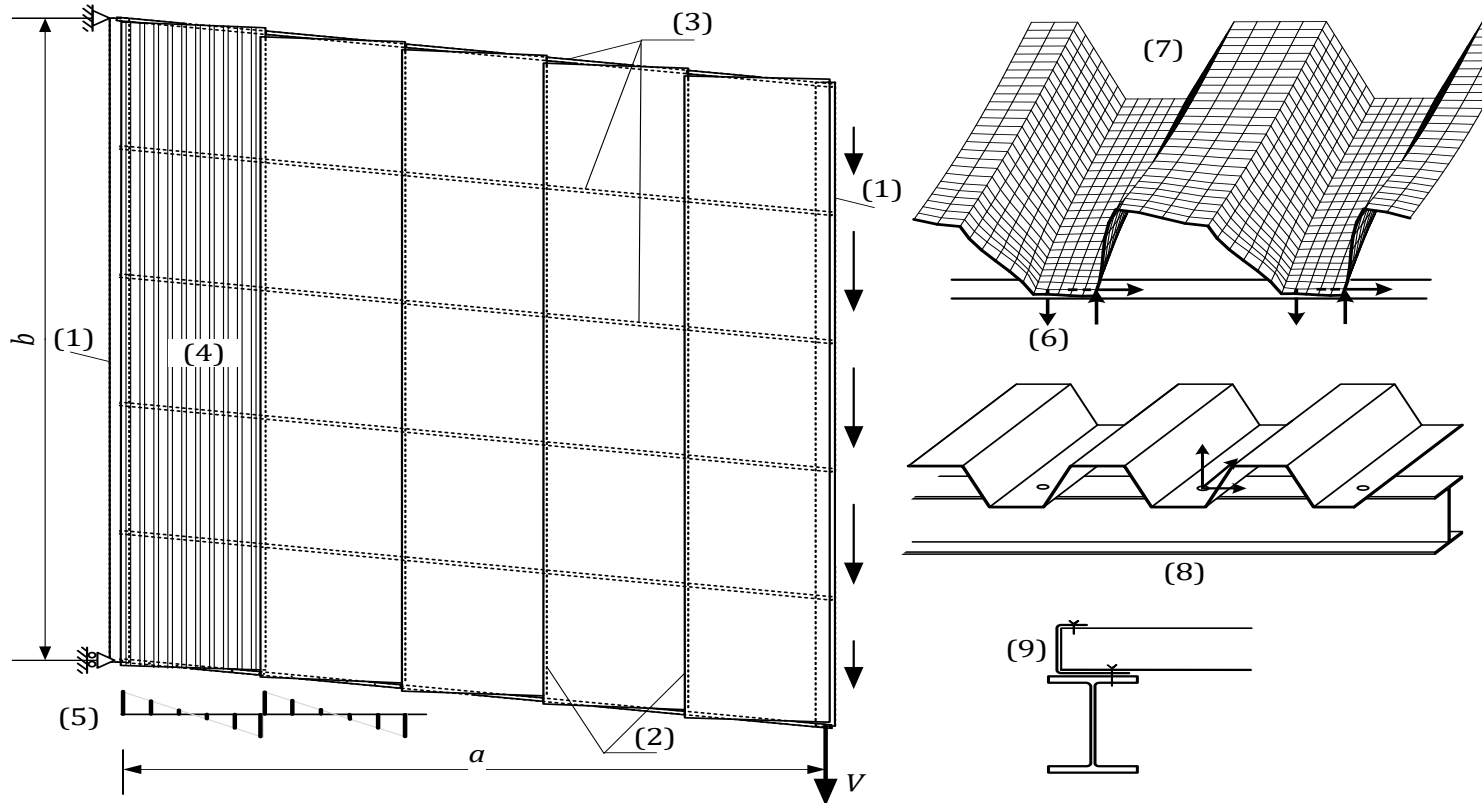



How ease of use has been enhanced

- *Improved wording and editorial updates*
- *Keep existing rules familiar to users*

Overview of the Evolution of EN1999-1-5: Shell Structures

Agenda – Evolution of EN1999-1-5: shell structures



- Key changes to Evolution of EN1999-1-5: shell structures
- New content included in the scope of Evolution of EN1999-1-5: shell structures
- How ease of use has been enhanced

Key changes to EN1999-1-5

- *New, more accurate formulation for imperfection reduction factors given in Annex A, related to unstiffened and stiffened shells under axial load, circumferential pressure and shear, including the case of axial compression with coexistent internal pressure*
- *Better fitting of buckling curves against benchmarked available data, also considering the addition of a new material class in EN1999, which led to three buckling classes A, B and C*

New content included in scope of EN1999-1-5

- *Minor changes has been made in the content list of EN1999-1-5.*
- *Major changes have been done to Annex A dealing with buckling formulae for cylinders, cones and spheres*

How ease of use has been enhanced

- *Optimization of editorial layout and general improvement of wording*
- *Some rules have been simplified in order to remain familiar to users as much as possible*
- *Improved consistency with corresponding document of EC3 (EN1993-1-6)*