

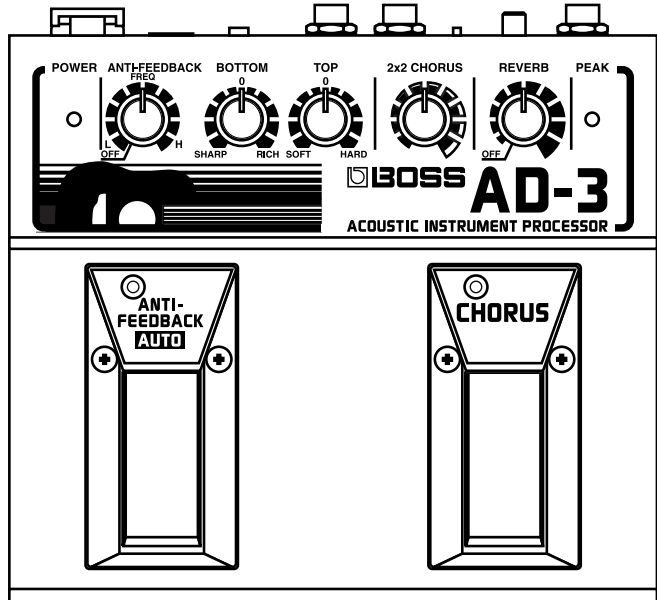

# AD-3



# ACOUSTIC INSTRUMENT PROCESSOR

## OWNER'S MANUAL











# USING THE UNIT SAFELY

## INSTRUCTIONS FOR THE PREVENTION OF FIRE, ELECTRIC SHOCK, OR INJURY TO PERSONS

About  WARNING and  CAUTION Notices







About the Symbols

 <b>WARNING</b>	Used for instructions intended to alert the user to the risk of death or severe injury should the unit be used improperly.
 <b>CAUTION</b>	Used for instructions intended to alert the user to the risk of injury or material damage should the unit be used improperly. * Material damage refers to damage or other adverse effects caused with respect to the home and all its furnishings, as well to domestic animals or pets.







	The  symbol alerts the user to important instructions or warnings. The specific meaning of the symbol is determined by the design contained within the triangle. In the case of the symbol at left, it is used for general cautions, warnings, or alerts to danger.
	The  symbol alerts the user to items that must never be carried out (are forbidden). The specific thing that must not be done is indicated by the design contained within the circle. In the case of the symbol at left, it means that the unit must never be disassembled.
	The  symbol alerts the user to things that must be carried out. The specific thing that must be done is indicated by the design contained within the circle. In the case of the symbol at left, it means that the power-cord plug must be unplugged from the outlet.

### ALWAYS OBSERVE THE FOLLOWING

#### WARNING

- Before using this unit, make sure to read the instructions below, and the Owner's Manual. 
- Do not open (or modify in any way) the unit or its AC adaptor. 
- Do not attempt to repair the unit, or replace parts within it (except when this manual provides specific instructions directing you to do so). Refer all servicing to your retailer, the nearest Roland Service Center, or an authorized Roland distributor, as listed on the "Information" leaflet. 
- Never use or store the unit in places that are:
  - Subject to temperature extremes (e.g., direct sunlight in an enclosed vehicle, near a heating duct, on top of heat-generating equipment); or are 
  - Damp (e.g., baths, washrooms, on wet floors); or are 
  - Exposed to rain; or are
  - Humid; or are
  - Dusty; or are
  - Subject to high levels of vibration.
- Make sure you always have the unit placed so it is level and sure to remain stable. Never place it on stands that could wobble, or on inclined surfaces. 

#### WARNING

- Use only the specified AC adaptor (PSA-Series), and make sure the line voltage at the installation matches the input voltage specified on the AC adaptor's body. Other AC adaptors may use a different polarity, or be designed for a different voltage, so their use could result in damage, malfunction, or electric shock.   

- Avoid damaging the power cord. Do not bend it excessively, step on it, place heavy objects on it, etc. A damaged cord can easily become a shock or fire hazard. Never use a power cord after it has been damaged. 
- This unit, either alone or in combination with an amplifier and headphones or speakers, may be capable of producing sound levels that could cause permanent hearing loss. Do not operate for a long period of time at a high volume level, or at a level that is uncomfortable. If you experience any hearing loss or ringing in the ears, you should immediately stop using the unit, and consult an audiologist. 
- Do not allow any objects (e.g., flammable material, coins, pins); or liquids of any kind (water, soft drinks, etc.) to penetrate the unit.   

## WARNING

- Immediately turn the power off, remove the AC adaptor from the outlet, and request servicing by your retailer, the nearest Roland Service Center, or an authorized Roland distributor, as listed on the "Information" leaflet when:
  - The AC adaptor or the power-supply cord has been damaged; or
  - Objects have fallen into, or liquid has been spilled onto the unit; or
  - The unit has been exposed to rain (or otherwise has become wet); or
  - The unit does not appear to operate normally or exhibits a marked change in performance.
- In households with small children, an adult should provide supervision until the child is capable of following all the rules essential for the safe operation of the unit.
- Protect the unit from strong impact. (Do not drop it!)
- Do not force the unit's power-supply cord to share an outlet with an unreasonable number of other devices. Be especially careful when using extension cords—the total power used by all devices you have connected to the extension cord's outlet must never exceed the power rating (watts/amperes) for the extension cord. Excessive loads can cause the insulation on the cord to heat up and eventually melt through.
- Before using the unit in a foreign country, consult with your retailer, the nearest Roland Service Center, or an authorized Roland distributor, as listed on the "Information" leaflet.
- Batteries must never be recharged, heated, taken apart, or thrown into fire or water.

## CAUTION

- The unit and the AC adaptor should be located so their location or position does not interfere with their proper ventilation.
- Always grasp only the plug or the body of the AC adaptor when plugging into, or unplugging from, an outlet or this unit.

## CAUTION

- Whenever the unit is to remain unused for an extended period of time, disconnect the AC adaptor.
- Try to prevent cords and cables from becoming entangled. Also, all cords and cables should be placed so they are out of the reach of children.
- Never climb on top of, nor place heavy objects on the unit.
- Never handle the AC adaptor body, or its plugs, with wet hands when plugging into, or unplugging from, an outlet or this unit.
- Before moving the unit, disconnect the AC adaptor and all cords coming from external devices.
- Before cleaning the unit, turn off the power and unplug the AC adaptor from the outlet (p. 8).
- Whenever you suspect the possibility of lightning in your area, disconnect the AC adaptor from the outlet.
- If used improperly, batteries may explode or leak and cause damage or injury. In the interest of safety, please read and observe the following precautions (p. 8).
  - Carefully follow the installation instructions for batteries, and make sure you observe the correct polarity.
  - Avoid using new batteries together with used ones. In addition, avoid mixing different types of batteries.
  - Remove the batteries whenever the unit is to remain unused for an extended period of time.
  - If a battery has leaked, use a soft piece of cloth or paper towel to wipe all remnants of the discharge from the battery compartment. Then install new batteries. To avoid inflammation of the skin, make sure that none of the battery discharge gets onto your hands or skin. Exercise the utmost caution so that none of the discharge gets near your eyes. Immediately rinse the affected area with running water if any of the discharge has entered the eyes.
  - Never keep batteries together with metallic objects such as ballpoint pens, necklaces, hairpins, etc.
- Used batteries must be disposed of in compliance with whatever regulations for their safe disposal that may be observed in the region in which you live.

# Contents

USING THE UNIT SAFELY .....	2
IMPORTANT NOTES .....	5

## **Introduction .....6**

Main Features .....	6
---------------------	---

## **Panel Descriptions.....7**

## **The Power Supply.....8**

Loading the Batteries .....	8
Using an AC Adaptor.....	8

## **Getting Ready to Play .....9**

Connections.....	9
Turning the Power On.....	10
Turning the Power Off.....	10

## **Making the Settings ..... 11**

Adjusting the Input Level.....	11
Adding Breadth to the Sounds (2 x 2 Chorus).....	11
Adding Reverberations to the Sounds (Reverb).....	12
Playing with a Guitar Amp (Acoustic Guitar Amp Simulator) .....	12
Adjusting the Bass Sound (Bottom) .....	13
Adjusting the Treble Sound (Top).....	13
Reducing Acoustic Feedback (Anti-feedback).....	14
Making the Setting with the Knob (the Anti-feedback Knob) .....	14
Automatic Detection with the Pedal (the Anti-feedback Auto Pedal) .....	14
Switching On the Anti-feedback Auto Function.....	15
Redoing Automatic Detection.....	15
Switching Off the Anti-feedback Auto Function .....	15

## **Appendices ..... 16**

Troubleshooting .....	16
Block Diagram .....	16
Setting Samples .....	17
Blank Chart .....	18
Specifications .....	19

---

## IMPORTANT NOTES

---

In addition to the items listed under “USING THE UNIT SAFELY” on page 2, please read and observe the following:

### Power Supply: Use of Batteries

- Do not use this unit on the same power circuit with any device that will generate line noise (such as an electric motor or variable lighting system).
- The AC adaptor will begin to generate heat after long hours of consecutive use. This is normal, and is not a cause for concern.
- The use of an AC adaptor is recommended as the unit’s power consumption is relatively high. Should you prefer to use batteries, please use the alkaline type.
- When installing or replacing batteries, always turn off the power on this unit and disconnect any other devices you may have connected. This way, you can prevent malfunction and/or damage to speakers or other devices.
- Batteries are supplied with the unit. The life of these batteries may be limited, however, since their primary purpose was to enable testing.
- Before connecting this unit to other devices, turn off the power to all units. This will help prevent malfunctions and/or damage to speakers or other devices.

### Placement

- Using the unit near power amplifiers (or other equipment containing large power transformers) may induce hum. To alleviate the problem, change the orientation of this unit; or move it farther away from the source of interference.
- This device may interfere with radio and television reception. Do not use this device in the vicinity of such receivers.

### Maintenance

- For everyday cleaning wipe the unit with a soft, dry cloth or one that has been slightly dampened with water. To remove stubborn dirt, use a cloth impregnated with a mild, non-abrasive detergent. Afterwards, be sure to wipe the unit thoroughly with a soft, dry cloth.
- Never use benzine, thinners, alcohol or solvents of any kind, to avoid the possibility of discoloration and/or deformation.

### Additional Precautions

- Use a reasonable amount of care when using the unit’s buttons, sliders, or other controls; and when using its jacks and connectors. Rough handling can lead to malfunctions.
- When connecting/disconnecting all cables, grasp the connector itself—never pull on the cable. This way you will avoid causing shorts, or damage to the cable’s internal elements.
- To avoid disturbing your neighbors, try to keep the unit’s volume at reasonable levels (especially when it is late at night).
- When you need to transport the unit, package it in the box (including padding) that it came in, if possible. Otherwise, you will need to use equivalent packaging materials.

# Introduction

Thank you, and congratulations on your choice of the BOSS AD-3 Acoustic Instrument Processor.

---

*Before using this unit, carefully read the sections entitled: "USING THE UNIT SAFELY" and "IMPORTANT NOTES" (p. 2; p. 5). These sections provide important information concerning the proper operation of the unit. Additionally, in order to feel assured that you have gained a good grasp of every feature provided by your new unit, this manual should be read in its entirety. The manual should be saved and kept on hand as a convenient reference.*

---

## Main Features

---

### A go-anywhere, floor-type effects processor for electric acoustic guitars, designed especially for live performances

- Equipped with two pedals (chorus and anti-feedback auto)
- Low-profile, rugged steel body

### Chorus and reverb tuned exclusively for electric acoustic guitars

- Uses a stereo band-splitting chorus (2 x 2 chorus) to apply effects separately to the bass and treble bands
- A newly developed, built-in reverb
- The same level of quality as the full-featured AD-5

### An acoustic guitar-amp simulator you can hook up and use with a guitar amp

- The AD-3 has an on-board acoustic guitar amp simulator approaches the original sound of an acoustic guitar, even with a guitar amp

### Bottom and top control designed exclusively for electric acoustic guitars

- The AD-3 has on-board bottom and top control for special filters that work differently for boost and cutoff. This makes for a natural acoustic sound.

### Double anti-feedback reduces acoustic feedback

- Along with the anti-feedback that sets the frequency with a control knob, the AD-3 has a built-in automatic anti-feedback function that automatically detects the frequency by operating a pedal.
- You can use the two anti-feedback functions at the same time.



*"Anti-feedback" is a feature that reduces acoustic feedback (howling) between the guitar and amp.*

### Balance output

- The AD-3's output is balanced, so you can connect it directly to PA systems.



*"Balanced output" is a system that reduces noise when using stereo cables and so on to send musical signals to a PA system or another balanced device.*

### Dual Power Supply

- In addition to running the AD-3 off batteries (six AA cells), you can use the AC adaptor. This means you can use batteries for an on-stage performance or the AC adaptor when in your room.

**Copyright © 1998 BOSS CORPORATION**

All rights reserved. No part of this publication may be reproduced in any form without the written permission of BOSS CORPORATION.

# Panel Descriptions

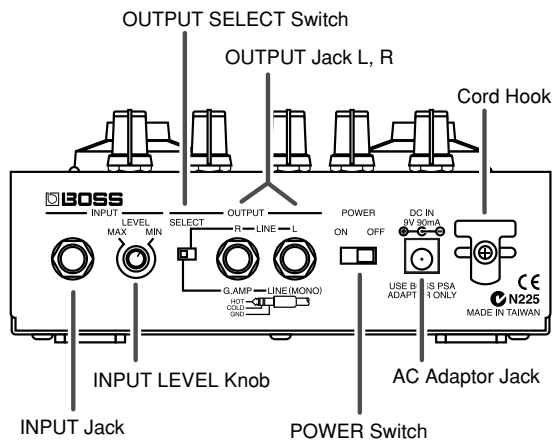
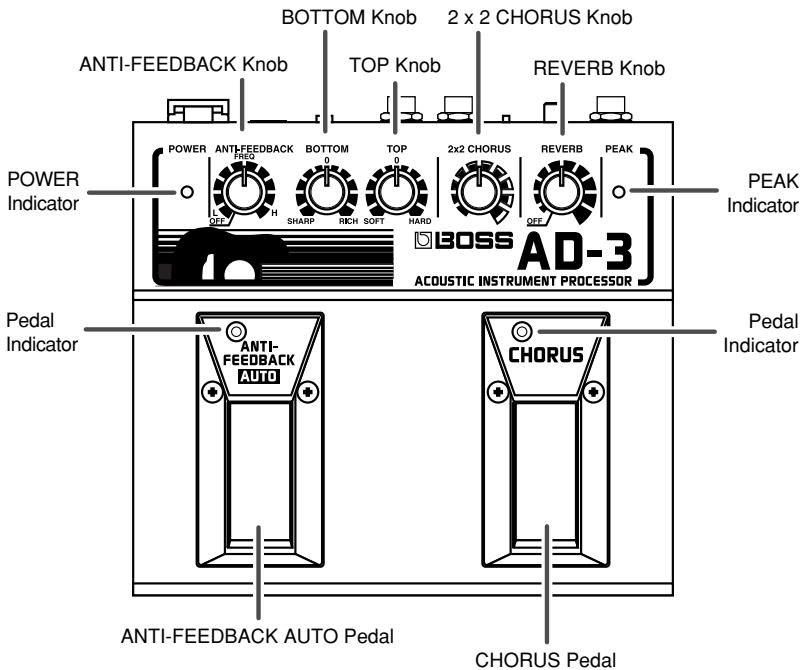

# The Power Supply

## Loading the Batteries

Make sure the “+” and “-” ends of the batteries are oriented correctly.

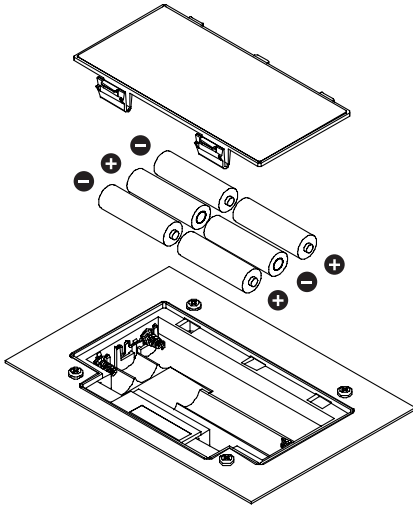

When the batteries are depleted, the power indicator grows dark. If this happens, replace with new batteries.

**NOTE** When replacing the batteries, use six AA batteries. Also, do not mix new and old batteries or batteries of different types. Doing so may cause fluid to leak from the batteries.

**NOTE** Make sure the “+” and “-” ends of the batteries are oriented correctly.

**NOTE** Battery life may vary according to battery type.

**MEMO** Expected battery life under continuous use:  
Alkaline: Approx. 17 hours  
Carbon: Approx. 9 hours  
These figures will vary depending on the actual conditions of use.

## Using an AC Adaptor

The BOSS PSA Series AC adaptor (sold separately) can be used to run the AD-3 from a household electrical outlet.

AC Adaptor  
(PSA-Series; sold separately)

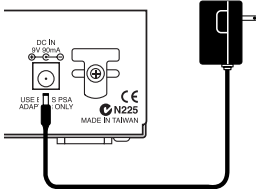

**NOTE** Use only a dedicated AC adaptor (BOSS PSA Series). Never try to use another AC adaptor, because doing so may result in incorrect operation or breakdown.

**MEMO** If there are batteries in the unit while an AC adaptor is being used, normal operation will continue should the line voltage be interrupted (power blackout or power cord disconnection).

**NOTE** To prevent the inadvertent disruption of power to your unit (should the plug be pulled out accidentally), and to avoid applying undue stress to the AC adaptor jack, anchor the power cord using the cord hook, as shown in the illustration.

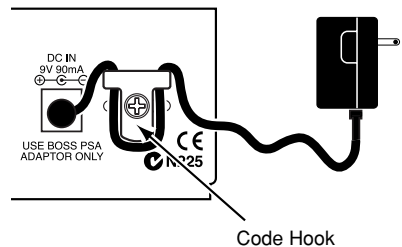



# Getting Ready to Play

## Connections

Connect your guitar and amp to the AD-3 as shown below.

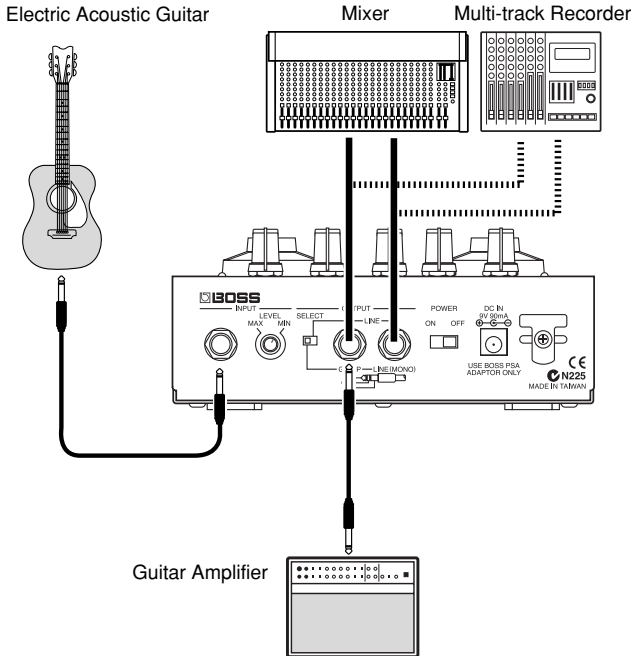

If you're using a guitar amp, connect the OUTPUT R jack to the guitar amp and set the OUTPUT SELECT switch to G.AMP.

If you're using stereo output and connecting the AD-3 to an audio amp, a mixer, a multi-track recorder, or the like, set the OUTPUT SELECT switch to LINE.

The AD-3 supports balanced output. For balanced output, use a commercially available stereo standard cord or a stereo (standard) ↔ Canon conversion cord.

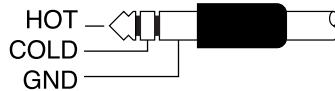

**NOTE** To prevent malfunction and/or damage to speakers or other devices, always turn down the volume, and turn off the power on all devices before making any connections.

**NOTE** Turn on the power on all connected equipment before you turn up the volume on your amplifier.

---

# Turning the Power On

---

Once the connections have been completed (p. 9), turn on power to your various devices in the order specified. By turning on devices in the wrong order, you risk causing malfunction and/or damage to speakers and other devices.

AD-3 → Output Equipment  
(Guitar Amp or Other Device)

---

## 1. Switch on the power for the AD-3.



The power indicator lights up and the power comes on.

---

## 2. Turn on the output equipment.

### NOTE

*This unit is equipped with a protection circuit. A brief interval (a few seconds) after power-up is required before the unit will operate normally. The peak indicator blinks for a few seconds, then you can use the AD-3 for playing.*

### NOTE

*When running off batteries, the AD-3 won't switch on unless there's something plugged into the INPUT jack. This helps prevent running down the batteries. Be careful, because if you unplug the equipment plugged into the INPUT jack, the power switches off.*

# Turning the Power Off

Power down in the reverse order: first the output equipment, then the AD-3.

Output Equipment → AD-3  
(Guitar Amp or Other Device)

---

## 1. Turn off the output equipment.

---

## 2. Switch off the power for the AD-3.



# Making the Settings

## Adjusting the Input Level

Output levels may vary greatly with the particular guitar that's connected. Unsuitable or incorrect levels may prevent full expression of the AD-3's abilities. In such cases, adjust the Input Level knob on the AD-3 to match the guitar's output level.

### 1. Adjust the knobs as shown below.

Input Level knob	MIN
Anti-feedback knob	OFF
Bottom knob	Centered
Top knob	Centered
2 x 2 Chorus knob	Left-most setting
Reverb knob	OFF

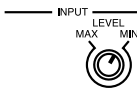
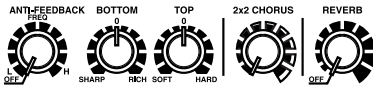

### 2. Adjust the Input Level knob so that the peak indicator lights up momentarily when you play the guitar forcefully.

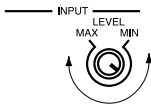

After adjusting the input level and the various knobs, play the guitar. If the peak indicator lights up frequently, then lower the input level.



The peak indicator lights up at 6 dB below clipping level (when distortion begins to occur).

## Adding Breadth to the Sounds (2 x 2 Chorus)

Chorus can add a broader, thicker effect to sounds. The chorus used in the AD-3 is a band-splitting stereo type for acoustic guitars. Chorus can be applied simultaneously to both bass and treble ranges in both left and right channels.

You use the Chorus pedal on the AD-3 to toggle the chorus effects on and off.

### 1. Press the Chorus pedal.

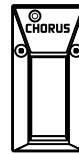

The pedal indicator lights up to show that Chorus is on. Press the pedal again to turn off Chorus.

### 2. Adjust the 2 x 2 Chorus knob.

2x2 CHORUS



Turning the control knob clockwise deepens the chorus effects. Turning it counterclockwise lessens the effects.

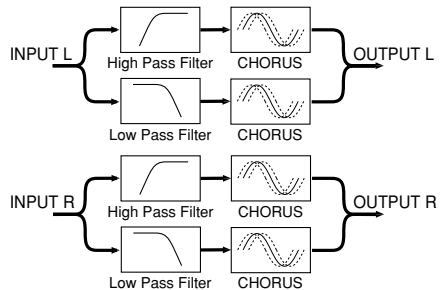

---

## Adding Reverberations to the Sounds (Reverb)

---

Reverb is the reverberant effect achieved when sounds reflected by walls and floors overlap and blend. The actual reverb changes according to factors such as size and shape of the space (such as a room or hall), the composition of the surface (a wall, for example) reflecting the sound, and so on.

With the AD-3, these elements are digitally simulated to obtain the optimal reverb for the acoustic guitar.

---

### 1. Adjust the Reverb knob.



Turning the control knob clockwise deepens the reverb effects. Turning it counterclockwise lessens the effects, and turning it all the way counterclockwise turns it off.

---

## Playing with a Guitar Amp (Acoustic Guitar Amp Simulator)

---

This feature makes what you play sound closer to an authentic acoustic guitar, even when you're playing with a guitar amp hooked up.

---

### 1. Set the OUTPUT SELECT switch to G.AMP.

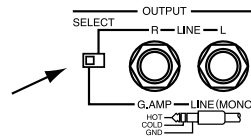

When set to G.AMP, the acoustic guitar amp simulator is on.



When on, output is as follows:

**G.AMP:**

*Output passes through the acoustic guitar amp simulator (mono)*

**LINE (MONO):**

*Output does not pass through the acoustic guitar amp simulator (mono)*

---

## Adjusting the Bass Sound (Bottom)

---

This knob adjusts the sound of the guitar's sound box, or suppresses excess bass notes.

.....

### 1. Adjust the Bottom knob.

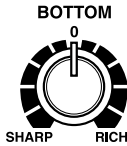

Setting this more toward RICH accents the richness of the sound-box reverberations, and setting it more toward SHARP suppresses the bands that interfere with vocals and the like, thus helping to prevent acoustic feedback (howling). Setting it to 0 produces flat characteristics.



*Adjusting the Bottom knob toward RICH may result in distortion. If this happens, lower the input level (p. 11).*

---

## Adjusting the Treble Sound (Top)

---

This knob adjusts the harmonic components, or suppresses the idiosyncrasies of piezo pickup sounds.

.....

### 1. Adjust the Top knob.



Setting this more toward HARD accents the higher harmonics, and setting more toward SOFT suppresses the piezo pickup's distinctive harshness, for a natural sound.



*Adjusting the Top knob toward HARD may result in distortion. If this happens, lower the input level (p. 11).*

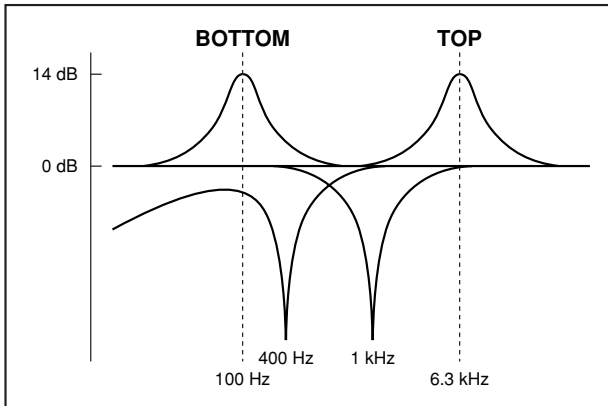

## Reducing Acoustic Feedback (Anti-feedback)

Anti-feedback is a feature that reduces acoustic feedback (howling) between the guitar and amp. This feature attenuates the sounds at the frequency where acoustic feedback occurs, thus suppressing the acoustic feedback.

The AD-3 has two types of built-in anti-feedback features. One sets the howling point with a control knob. The other automatically detects the howling point when you press the pedal. You can use both of these at the same time.



*If howling isn't suppressed using just anti-feedback, try adjusting the settings to lower the volume, suppress the bass range, and so on.*

### Making the Setting with the Knob (the Anti-feedback Knob)

Use the control knob to adjust the frequency for applying the anti-feedback effect and reduce howling.

It may be a good idea to set the howling point ahead of time, such as during rehearsal.

#### 1. Adjust the Anti-feedback knob to lessen acoustic feedback (howling).



Turn the knob clockwise to raise the frequency where the anti-feedback effect is applied. Turning the knob all the way counterclockwise switches the effect off.

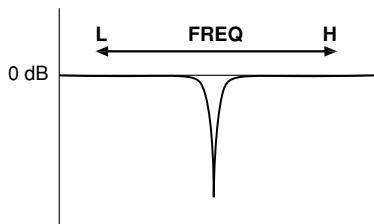

### Automatic Detection with the Pedal (the Anti-feedback Auto Pedal)

When acoustic feedback (howling) occurs, just depress the Anti-feedback Auto pedal to automatically detect the howling point and reduce the howling.

This can be handy when acoustic feedback (howling) suddenly occurs during a live performance or a concert.

The Anti-feedback Auto pedal uses three notch filters to suppress acoustic feedback (howling) at three points. The effect applied at each of the points is similar to the Anti-feedback knob.

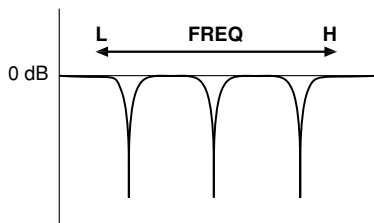

---

## Switching On the Anti-feedback Auto Function

---

### 1. Press the Anti-feedback Auto pedal.

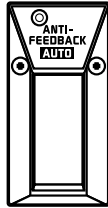

The pedal indicator blinks while detection of the howling point is in progress, and lights up steadily when detection ends.

**NOTE** Switching off the power returns the pedal to its off state.

**NOTE** When there's no input, no automatic detection is performed.

## Redoing Automatic Detection

---

### 1. Depress the pedal again.

## Switching Off the Anti-feedback Auto Function

---

### 1. Hold down the pedal for two seconds or more.

The pedal indicator blinks then goes dark, and the Anti-feedback Auto function is switched off.

**NOTE** Switching off the power returns the pedal to its off state.

# Appendices

## Troubleshooting

If there is no sound, or if you think that the AD-3 may be malfunctioning, please first go through the following checkpoints. If after these checkpoints the problem is still unresolved, consult your nearest Roland service center or authorized Roland distributor.

### The Power Doesn't Come On

#### Are the batteries installed correctly?

Make sure the "+" and "-" ends of the batteries (p. 8).

#### Are the batteries dead?

Replace with fresh batteries (p. 8).

#### Is the AC adaptor (PSA-Series; sold separately) connected correctly?

Check the connection again.

#### Is the guitar correctly plugged into the INPUT jack?

Check the connection again.

#### NOTE

When running off batteries, the AD-3 won't switch on unless there's something plugged into the INPUT jack. This helps prevent running down the batteries.

### No Sound/Low Volume/Different Volume on the Left and Right

#### Is the other equipment connected correctly?

Check the connections again.

#### Is the volume turned down on the connected amp, mixer, external effects processor, or other equipment?

#### Is the Input Level knob turned down too far?

#### Is the Output Select switch on the rear panel set to G.AMP?

When the switch is set to G.AMP, the sounds and volume levels for left and right output are different.

### Sound Is Distorted (The peak indicator lights up frequently.)

#### Have you adjusted the input level?

Adjust the Input Level knob (p. 11).

#### Have the Bottom or Top knobs been turned too far?

When the Bottom or Top knob is turned clockwise too far, some input signals may be distorted. Adjust the Input Level knob (p. 11).

#### Are the batteries dead?

When the batteries run down, the power indicator grows dark, and the unit may not run normally. Replace with fresh batteries (p. 8).

## Block Diagram

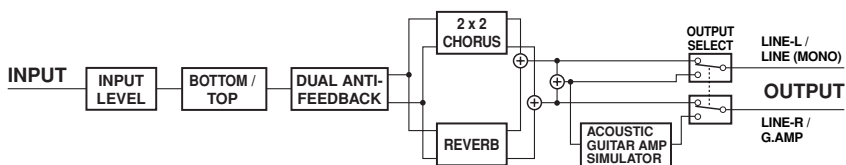



---

# Setting Samples

---

## Flat Back

### Fusion

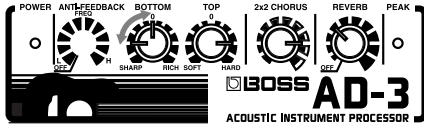

## Round Back

### Fusion

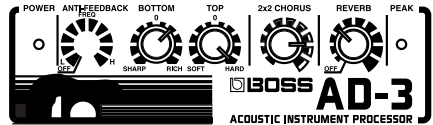

### Unplugged Rock

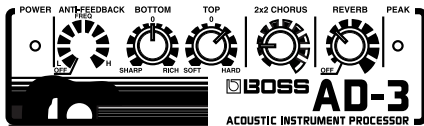

### Unplugged Rock

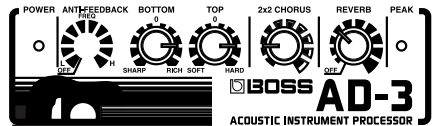

### 70's Folk

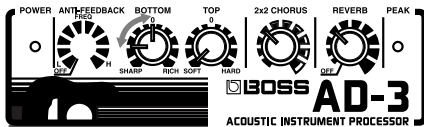

### 70's Folk

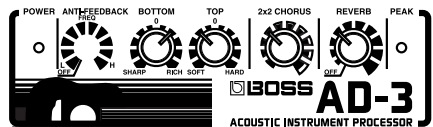

### Blues

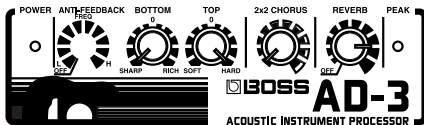

### Blues

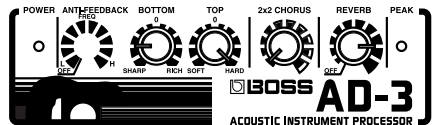

# Blank Chart

.....

.....

.....

.....

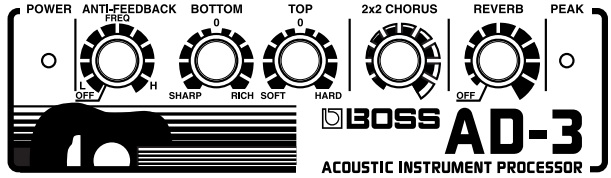

.....

.....

.....

.....

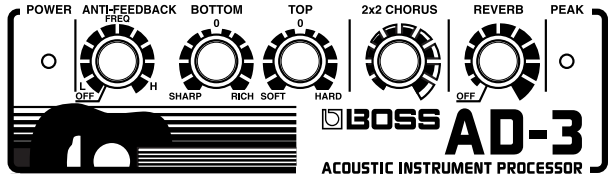

.....

.....

.....

.....

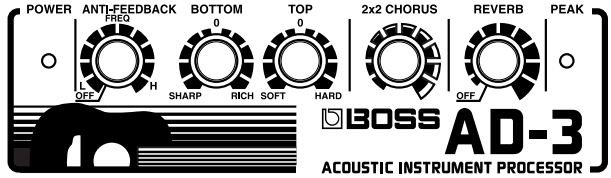

.....

.....

.....

.....

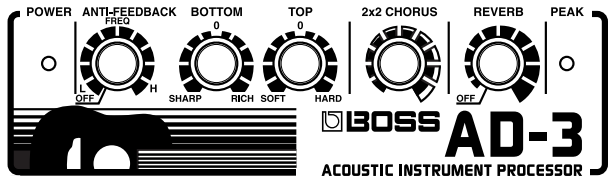

# Specifications

## AD-3: ACOUSTIC INSTRUMENT PROCESSOR

### AD Conversion

20 bit  $\Delta\Sigma$  Method

### DA Conversion

20 bit  $\Delta\Sigma$  Method

### Sample Rate

44.1 kHz

### Nominal Input Level

-10 dBm

### Input Impedance

4.7 M $\Omega$

### Nominal Output Level

OUTPUT: -10 dBm

OUTPUT (balanced): -10 dBm into 600  $\Omega$

### Output Impedance

OUTPUT: 300  $\Omega$

OUTPUT (balanced): 600  $\Omega$

### Controls

INPUT LEVEL Knob

ANTI-FEEDBACK Knob

BOTTOM Knob

TOP Knob

2 x 2 CHORUS Knob

REVERB Knob

OUTPUT SELECT Switch

ANTI-FEEDBACK AUTO Pedal

CHORUS Pedal

POWER Switch

### Indicators

ANTI-FEEDBACK AUTO

CHORUS

POWER

PEAK

### Connectors

INPUT Jack

OUTPUT Jacks (L/R 1/4 inch TRS Phone Type)

AC Adaptor Jack

### Power Supply

Dry battery (LR6 (AA) type) x 6

DC 9 V (PSA-Series; sold separately)

### Current Draw

90 mA

### Expected battery life under continuous use:

Alkaline: Approx. 17 hours

Carbon: Approx. 9 hours

These figures will vary depending on the actual conditions of use.

### Dimensions

170 (W) x 156 (D) x 70 (H) mm

6-3/4 (W) x 6-3/16 (D) x 2-13/16 (H) inches

### Weight

1.0 kg (including batteries)

2 lbs 4 oz

### Accessories

Dry battery (LR6 (AA) type) x 6

Owner's Manual

Information

### Options

AC Adaptor PSA-Series

(0 dBm = 0.775 V rms)

### NOTE

*In the interest of product improvement, the specifications and/or appearance of this unit are subject to change without prior notice.*



This product complies with the requirements of European Directive 89/336/EEC.

For EU Countries

## FEDERAL COMMUNICATIONS COMMISSION RADIO FREQUENCY INTERFERENCE STATEMENT

For the USA

This equipment has been tested and found to comply with the limits for a Class B digital device, pursuant to Part 15 of the FCC Rules. These limits are designed to provide reasonable protection against harmful interference in a residential installation. This equipment generates, uses, and can radiate radio frequency energy and, if not installed and used in accordance with the instructions, may cause harmful interference to radio communications. However, there is no guarantee that interference will not occur in a particular installation. If this equipment does cause harmful interference to radio or television reception, which can be determined by turning the equipment off and on, the user is encouraged to try to correct the interference by one or more of the following measures:

- Reorient or relocate the receiving antenna.
- Increase the separation between the equipment and receiver.
- Connect the equipment into an outlet on a circuit different from that to which the receiver is connected.
- Consult the dealer or an experienced radio/TV technician for help.

Unauthorized changes or modification to this system can void the users authority to operate this equipment.  
This equipment requires shielded interface cables in order to meet FCC class B Limit.

## NOTICE

For Canada

This Class B digital apparatus meets all requirements of the Canadian Interference-Causing Equipment Regulations.

## AVIS

Cet appareil numérique de la classe B respecte toutes les exigences du Règlement sur le matériel brouilleur du Canada.