

AUDIO *Canvas*
UA-100 AUDIO & MIDI
PROCESSING UNIT

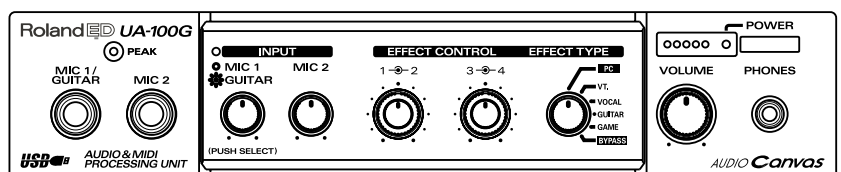

User's Guide



Copyright © 1999 ROLAND CORPORATION

All rights reserved. No part of this publication may be reproduced in any form without the written permission of ROLAND CORPORATION.

IMPORTANT NOTES

 **WARNING** DO NOT play a CD-ROM disc on a conventional audio CD player. The resulting sound may be of a level that could cause permanent hearing loss. Damage to speakers or other system components may result. 

- * Avoid touching or scratching the shiny underside (encoded surface) of the disc. Damaged or dirty CD-ROM discs may not be read properly. Keep your discs clean using a commercially available CD cleaner.
- * Before you open the included CD-ROM, you must read the "license agreement." Opening the CD-ROM will be taken to mean your acceptance of the terms of the license agreement.
- * In the interest of product improvement, the specifications and/or appearance of this unit are subject to change without prior notice.
- * Do not apply excessive force to the buttons or switches. Doing so can damage them, causing injury or electric shock.
- * Microsoft and Windows are registered trademarks of Microsoft Corporation.
- * Windows® 98 is known officially as: "Microsoft® Windows® 98 operating system."
- * Screen shots reprinted with permission from Microsoft Corporation.
- * Pentium is a registered trademark of Intel Corporation.
- * MMX is a trademark of Intel Corporation.
- * Cakewalk is a registered trademark of Twelve Tone Systems, Inc.
- * All product names mentioned in this document are trademarks or registered trademarks of their respective owners.

About This Document

This document is a helpful guide to everything you need to know to use the UA-100. It is organized into four sections.

- **Parts of the UA-100 and Their Functions**

This chapter explains the controls and other parts of the UA-100, and explains their functions.

- **Before you use the UA-100**

This chapter explains the internal signal flow of the UA-100, and provides an overview of the UA-100 Controller, which is software that lets you control the UA-100 from your computer. First you should refer to the Getting Started, and connect the UA-100 to your computer, make settings, and install the UA-100 Controller.

- **Using the UA-100**

This chapter explains the basics of using the UA-100 with a MIDI/audio sequencing software and with the UA-100 Controller. The explanation will assume that you are using a sequencing software with MIDI/audio recording capability, so please install and set up your sequencing software beforehand.



- **Appendices**

- **Troubleshooting**

These chapters provide information that you will find helpful as you use the UA-100, or points to check if you have questions or if you experience problems. Read this material as necessary.

The included CD-ROM contains Help and a Reference Manual for the UA-100 Controller. Read this material as necessary in order to gain a better understanding of the UA-100. The Reference Manual can be read using your web browser. For details refer to the Getting Started section “Using the reference manual.”

In the right side of the pages of this book, the following icons are accompanied by explanations of vocabulary or points of caution. These provide important information that you need to be aware of.

 MEMO	Explanation of terms
 NOTE	Points of caution

Contents

About This Document.....	3
Parts of the UA-100 and Their Functions	5
Front Panel.....	6
About the Effect Type Selector	8
About the Effect Controllers.....	9
Rear Panel	10
Before You Use the UA-100	11
The Signal Flow of the UA-100	12
About the UA-100 Controller	14
Using the UA-100	19
Recording Vocals	20
Recording Guitar	24
Recording from an Audio Device.....	28
Monitoring the Audio Data While You Record a New Part.....	32
Applying Effects While Playing Audio Data	35
Applying Effects While You Record.....	37
Monitoring the Effect Sound While You Record the Unprocessed (Dry) Sound ...	41
Re-recording Audio Data While Applying an Effect.....	45
Using Multiple Effects Simultaneously	49
Adding Harmony to a Vocal.....	53
Using the UA-100 as a MIDI Interface.....	56
Using MIDI Messages to Control the UA-100	58
Digitally Recording to MD/DAT.....	60
Appendices	61
Internal Block Diagram of the UA-100.....	62
Effect Parameters Chart.....	66
Effect Parameter Conversion Table	74
MIDI Implementation	78
MIDI Implementation Chart	90
Troubleshooting	91
Troubleshooting.....	92
Points to Check on the UA-100	92
Points to Check for the UA-100 Driver.....	105
Points to Check for the UA-100 Controller.....	106
Index.....	107

Parts of the UA-100 and Their Functions

This chapter explains the controls and other parts of the UA-100, and explains their functions. It also explains functions that you need to understand when using the UA-100, such as the Effect Type Selector and the Effect Controller.

Front Panel

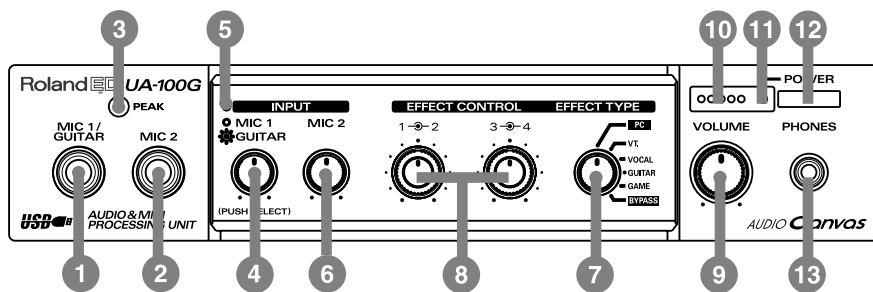

1 Mic 1/ Guitar Input Jack

A microphone or guitar can be connected to this jack.

2 Mic 2 Input Jack

A microphone can be connected to this jack.

Dynamic microphones are the only type of microphone that can be connected to the Mic 1/Guitar Input Jack and the Mic 2 Input Jack. The miniature microphones (condenser microphones) that may be included with your computer cannot be used.

3 Input Level/Peak Indicator

This indicator will light in green when there is an input signal from the Mic 1/Guitar Input Jack, the Mic 2 Input Jack, or the rear panel Line Input Jacks. If the input level is too high, the indicator will light in red.

4 Mic 1/Guitar Input Volume

This knob adjusts the input level of the microphone or guitar that is connected to the Mic 1/Guitar Input Jack. Rotating it counterclockwise will decrease the input level, and rotating it clockwise will increase the input level. By pressing this knob, you can switch between the microphone input and guitar input.

5 Mic 1/Guitar Function Indicator

This indicator shows whether the Mic 1/Guitar Input Jack is being used for a microphone or for a guitar. Each time you press the Mic 1/Guitar Input Volume Knob, the setting will alternate.

Lit: guitar

Extinguished: microphone

When the power is turned on, this will be lit (guitar)

6 Mic 2 Input Volume Knob

This adjusts the input level of the microphone that is connected to the Mic 2 Input Jack. Rotating it counterclockwise will decrease the input level, and rotating it clockwise will increase the input level.

7 Effect Type Selector

This knob selects the type of preset effect.

The UA-100 contains four preset effects. These are generally controlled from your computer using the UA-100 Controller, but you can also use this Effect Type Selector to make simple effect settings.

When controlling the effects from your computer, set the Effect Type Selector to the [PC] position.

For details refer to "About the Effect Type Selector" (p. 8).

8 Effect Controller 1/2, 3/4

These knobs adjust the parameters of the effect that is selected by the Effect Type Selector. The effect parameters assigned to each controller will depend on the effect type.

When the Effect Type Selector is in the [PC] or [BYPASS] position, the Effect Controller settings will not function.

For details refer to "About the Effect Controllers" (p. 9).

9 Line Output Volume

This knob adjusts the volume that is output from the Headphone Jack and the rear panel Line Output Jacks. Rotating the knob counterclockwise will decrease the volume, while rotating it clockwise will increase the volume. However, depending on the settings of the UA-100 Controller or the Effect Type Selector, the signal from the Line Input Jacks may be output directly, so that it will not be possible to adjust the volume.

10 Output Level Indicators

The number of LED's that light will depend on the output from the Headphone Jack and the rear panel Line Output Jacks. If the red LED lights, you should lower the Line Output Volume.

11 Power Indicator

Lights when the power is on.

12 Power Switch

Press this switch to turn the power on/off.

13 Headphone Jack

A pair of headphones can be connected to this jack. Even if headphones are connected, sound will still be output from the rear panel Line Output Jacks.

About the Effect Type Selector

The UA-100 has six operating modes that are appropriate for differing uses. The front panel Effect Type Selector is used to switch between these operating modes.

■ PC mode

Select this mode when you wish to control the UA-100's effects from your computer. This mode contains an additional three modes (VT Effect mode, Full Effect mode, Compact effect mode). For details on these effect modes, refer to the reference manual.

■ VT mode

Select this mode when you wish to use the Effect Controller knobs on the front panel of the UA-100 to control the VT (Voice Transformer) effect. In this mode, the VT effect will be applied to the input signal from the front panel Mic 1/Guitar Input Jack. If the UA-100 is connected to a computer, you can use the UA-100 Controller to change the effect parameters that are assigned to be controlled by the front panel Effect Controller knobs 1-4. You can also use the UA-100 Controller to specify the default settings of the effect parameters that will be used when VT mode is selected.

■ VOCAL mode

In this mode, you can use the effect controller knobs of the UA-100 to control the Vocal Multi effect. In this mode, the effect will be applied to the signal that is input from the front panel Mic 1/Guitar Input Jack. If the UA-100 is connected to a computer, you can use the UA-100 Controller to change the effect parameters that are assigned to be controlled by the front panel Effect Controller knobs 1-4. You can also use the UA-100 Controller to specify the default settings of the effect parameters that will be used when VOCAL mode is selected.

■ GUITAR mode

In this mode, you can use the effect controller knobs of the UA-100 to control the Guitar Multi 1 effect. In this mode, the effect will be applied to the signal that is input from the front panel Mic 1/Guitar Input Jack. If the UA-100 is connected to a computer, you can use the UA-100 Controller to change the effect parameters that are assigned to be controlled by the front panel Effect Controller knobs 1-4. You can also use the UA-100 Controller to specify the default settings of the effect parameters that will be used when GUITAR mode is selected.

■ GAME mode

Select this mode when the UA-100 is connected to your computer and you wish to apply the UA-100's Game effect to the output of the computer's audio device. In this mode, the effect will be applied to the signal that is input to the Roland UA-100 Wave 1 audio device. You can use the UA-100 Controller to change the effect parameters that are assigned to be controlled by the front panel Effect Controller knobs 1-4. You can also use the UA-100 Controller to specify the default settings of the effect parameters that will be used when GAME mode is selected.

■ BYPASS mode

Select this mode when you want the input signal from the front panel Mic 1/Guitar Input Jack and the Mic 2 Input Jack to be output without change.

About the Effect Controllers

You can control the effects of the UA-100. The effect parameters assigned to each knob will differ depending on the effect type.

With the factory settings, they have the following assignments.

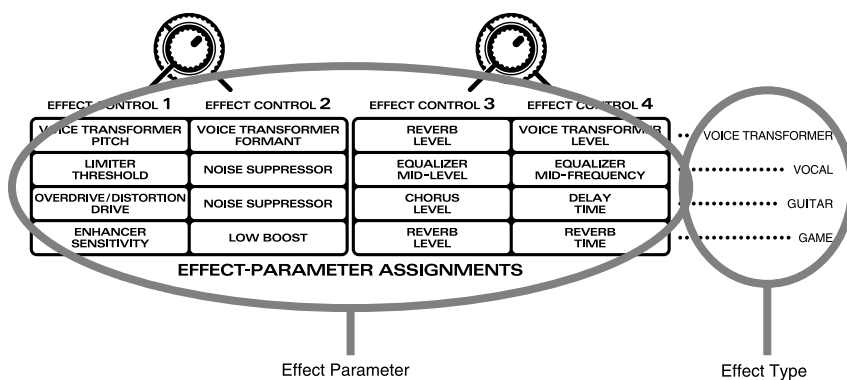

(This is also printed on the top panel of the UA-100.)

When you switch the Effect Type Selector, the value of each effect parameter will be reset to the default value regardless of the position of the effect controller knobs. You can move the effect controller knobs to adjust the parameters.

You can use the UA-100 Controller to change the parameters that are assigned to each effect controller and the default values of the parameters. For details refer to "About the UA-100 Controller" (p. 14) and the UA-100 Controller Help.

If the Effect Type Selector is in the PC or BYPASS position, the effect controller settings will not function. In order to enable the effect controller settings, you must set the Effect Type Selector to a position other than PC or BYPASS.

Rear Panel

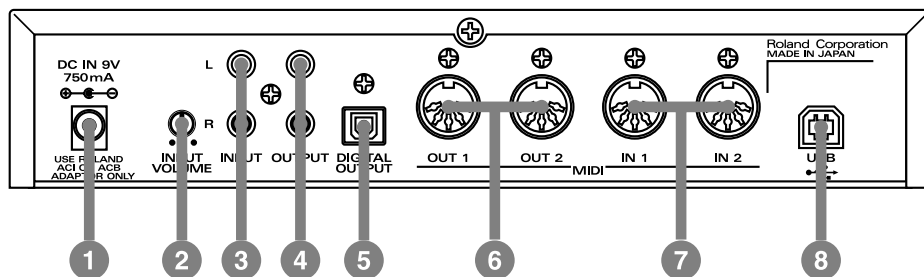

- 1 AC Adaptor Jack**
Connect the supplied AC adaptor to this jack.
- 2 Line Input Volume**
This knob adjusts the audio input level from the Line Input Jacks. If the input level exceeds the peak (i.e., if it is too loud), the front panel input level peak indicator will light in red.
- 3 Line Input Jacks**
Connect these jacks to your external MIDI sound module, or to the LINE OUT of an audio device such as MD or DAT.
- 4 Line Output Jacks**
Connect these jacks to your stereo or audio system.
- 5 Digital Output Connector**
Connect an optical digital cable to this connector when you wish to digitally output the audio signal to a digital recorder such as MD or DAT.
- 6 MIDI OUT 1/2 Connectors**
Transmit MIDI messages to other MIDI devices.
- 7 MIDI IN 1/2 Connectors**
Receive MIDI messages from other MIDI devices.
- 8 USB Connector**
You can use a USB cable to connect this to your computer so that audio signals and MIDI messages can be exchanged.

Before You Use the UA-100

Before you begin using the UA-100, please read the following explanations of the internal signal flow inside the UA-100, and the UA-100 Controller software which controls the signal flow.

The Signal Flow of the UA-100

The UA-100 consists of an audio block which handles audio signals, and a MIDI interface block that handles MIDI messages.

Audio Block

The audio block is divided into an analog mixer and a digital mixer. The portion enclosed in a dotted line is the analog mixer, and the digital mixer is located in the center. The digital mixer contains a proprietary Roland effect processor that uses technology developed for its musical instruments, and applies various effects to the audio signal.



For details on the signal flow of the UA-100, refer to "Internal Blocks of the UA-100" (p. 64) in the Appendices.

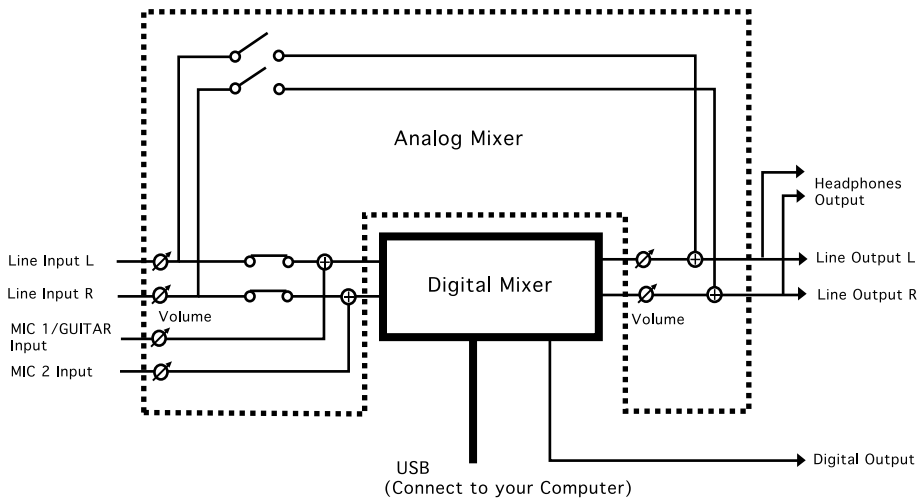

MIDI Interface Block

If your computer and the UA-100 are connected via a USB cable, the UA-100 will have two MIDI ports for controlling external MIDI devices (MIDI IN 1, 2 and MIDI OUT 1, 2), and one MIDI port for controlling the UA-100 (UA-100 MIDI Control IN, OUT).

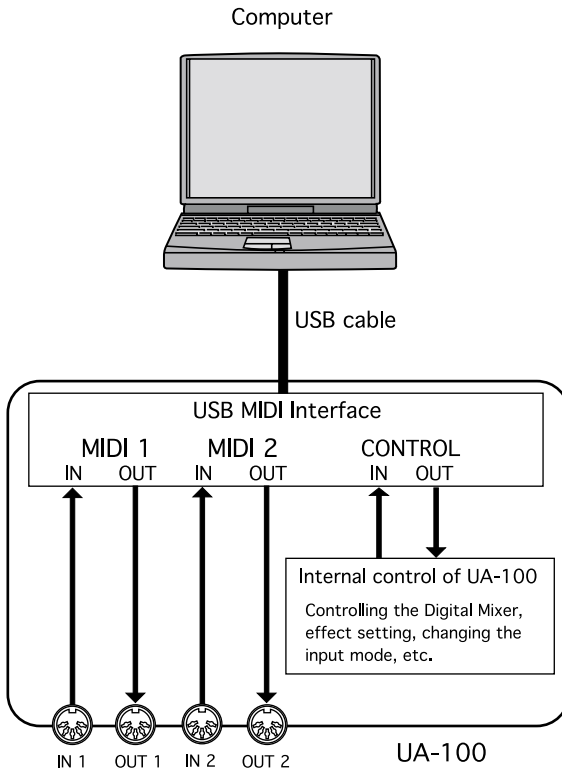

If your computer and the UA-100 are not connected via a USB cable, MIDI messages from the MIDI IN 1 connector will be routed to internal control of the UA-100, allowing an external MIDI device to control the UA-100.

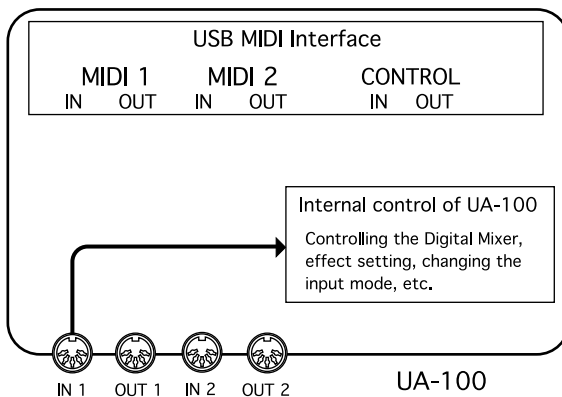

About the UA-100 Controller

The UA-100 Controller is software that monitors the state of the UA-100 and is able to control it.

- * *If the power switch is off, or if the USB connector is disconnected, the UA-100 Controller will exit automatically. (Since the settings of the mixer window and effect window are saved automatically when the program exits, these settings can be recovered by opening the windows the next time the program is started up.)*

Main window

When you start up the UA-100 Controller, the **Main** window will open first.

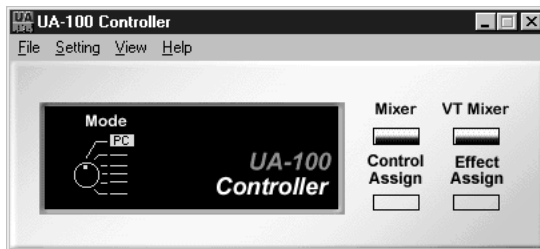

This main window has the following functions.

- **Effect Type Selector display**
The current position (mode) of the Effect Type Selector knob will be shown as **Mode** in the UA-100 Controller.
- **Display buttons for the windows of the UA-100 Controller**
When you click the following buttons, the corresponding window will open. The windows that can be displayed will depend on the mode of the Effect Type Selector.

Button	Mode
Mixer	[PC], [VT], [VOCAL], [GUITAR], [GAME], [BYPASS]
VT Mixer	[PC]
Control Assign	[VT], [VOCAL], [GUITAR], [GAME]
Effect Assign	[VT], [VOCAL], [GUITAR], [GAME]

- **UA-100 internal parameter settings**
By selecting **System setting** from the **Setting** menu, you can set internal parameters of the UA-100. For details refer to UA-100 Controller Help.
- **Viewing the UA-100 Controller Help**
From the **Help** menu, select **UA-100 Controller Help** to start up Help for the UA-100 Controller.

Mixer window

When you click **[Mixer]** in the **main** window, the **mixer** window will appear. Here you can set the volume of the line input and of the input from the computer, adjust the volume of the output from the UA-100, and select the output source to specify how the signal will be routed and processed.



For details on the Mixer window, refer to the UA-100 Controller Help.

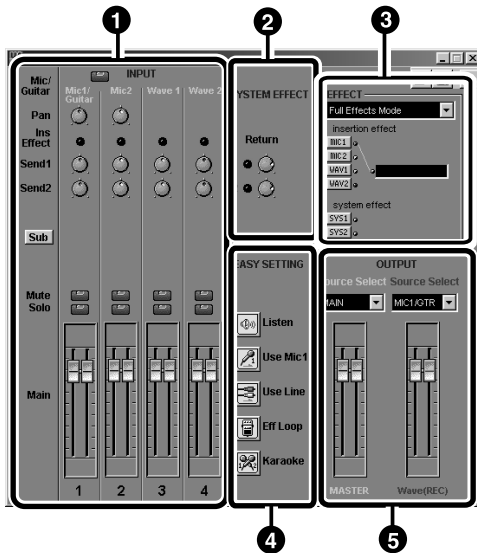

* The diagram shown is for when the Effect Type Selector is at **[PC]**. The content that can be controlled in the **Mixer** window will depend on the setting of the Effect Type Selector.

1 INPUT

INPUT in the upper left contains controllers (knobs) that control the **pan** (left/right proportion), **Send 1** (level of the signal sent to system effect 1), and **Send 2** (level of the signal sent to system effect 2). The **Sub** button is used to switch the Sub fader on/off.

In the lower are the **Main faders** which control the levels of **Mic1/GUITAR**, **Mic2**, **Wave1**, and **Wave2**. Each fader has a **Mute** and a **Solo** button.

2 SYSTEM EFFECT

SYSTEM EFFECT shown in the upper middle of the screen contains two controllers (knobs) that control the system effect levels.

3 EFFECT

EFFECT lets you choose between the two **Insertion Effect** modes: **Compact Effects Mode** or **Full Effects Mode**. To apply an effect, click the appropriate effect select button (**LINE**, **MIC1**, **MIC2**, **WAV1**, **WAV2**, **SYS1**, **SYS2**).

4 EASY SETTING

The **EASY SETTING** buttons let you automatically set input sources and output routings simply by pressing a button.

5 OUTPUT

OUTPUT lets you select the output sources, and control the master output level. **Master Source Selector** (**Source Select: white**) selects the source to be monitored. At the right, **Wave Source Selector** (**Source Select: red**) selects the source to be recorded.

Effects window

Click the **effect select buttons** of the Mixer window to open this. Here you can control the internal digital effects of the UA-100. The following three types of effect window are provided.

- 64 compact effect windows that can be used in conjunction with a system effect
- System effect windows for Delay, Chorus, and Reverb
- 6 full-effect windows such as Vocoder and Mic Simulator

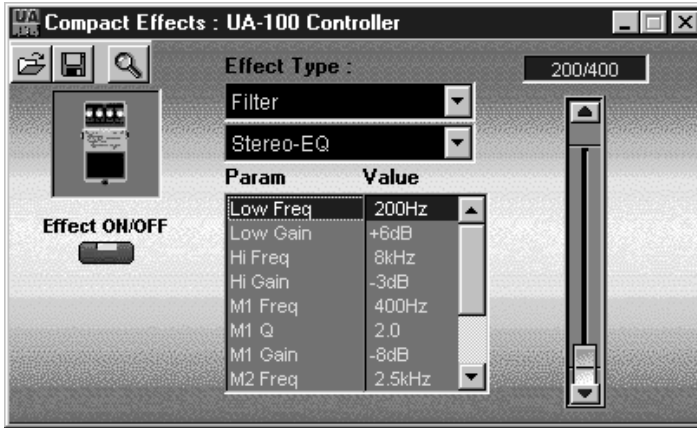

For details on effects, refer to UA-100 Controller Help and to the reference manual.

VT Mixer window

This will open when you click [VT Mixer] in the Main window. VT is a unique effect designed specially for voice, that can create unique vocal characters. The pitch and formants (the tonal character determined by the dimensions of the vocal cords and throat) can be controlled independently.



For details on the VT Mixer, refer to the UA-100 Controller Help.

Control Assign window

When you use the UA-100 Effect Type Selector to select VT/Vocal/Guitar/GAME, **[Control Assign]** will appear in the **Main** window.

When you click this button, the **Control Assign** window will open. When the UA-100 is used by itself, four effects (VT, Vocal, Guitar, Game) can be used. The UA-100 has four effect controllers that can control the parameters of these effects, and these parameter assignments can be modified. Since the assignments you change are remembered by the UA-100, they will still remain even when the UA-100 is disconnected from the computer.

* *This customization can be performed only by the UA-100 Controller. If you wish to make changes, you will need to re-connect the UA-100 to your computer.*

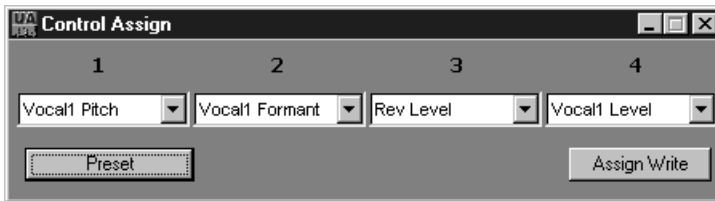

Assigning effects to the Effect Controller

1. Make sure that the UA-100 is connected to your computer.
2. Open the **Main** window of the UA-100 Controller.
3. Rotate the Effect Type Selector of the UA-100 to select the effect type. Control assignments can be made for four effect types such as VT/Vocal/Guitar/Game.
4. In the UA-100 Controller, click **[Control Assign]**. The **Control Assign** window will appear.
5. Assign a parameter to each effect controller. Assign a total of four parameters; one for the center and one for the outer concentric knobs of both Effect Control knobs. For each, choose a parameter from the drop-down list.
6. When you have finished making assignments, click **[Assign Write]** to write the settings into the UA-100.
7. If you wish to restore the assignments to the preset selections, click **[Preset]**.

Effect Assign window

When you use the Effect Type Selector of the UA-100 to select either VT, Vocal, Guitar, or Game, **[Effect Assign]** will appear in the **Main** window.

By clicking **[Effect Assign]**, you can open the **Effect Assign** window. When using the UA-100 by itself, you can use four types of effect (VT, Vocal, Guitar, Game). You can change the initial settings (default values) of these effects.

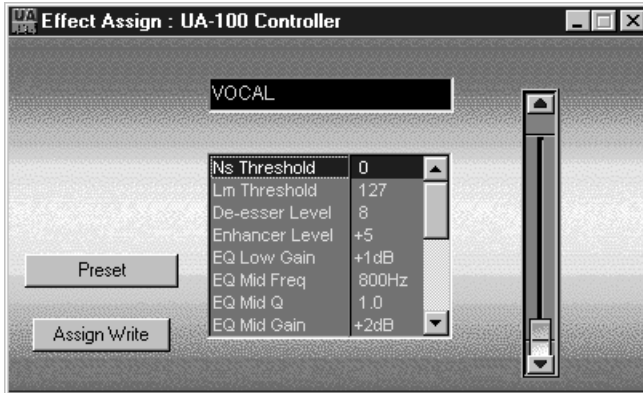

Since the default values you change are remembered by the UA-100, they will still remain even when the UA-100 is disconnected from the computer.

* *This customization can be performed only by the UA-100 Controller. If you wish to make changes, you will need to re-connect the UA-100 to your computer.*

Changing the default values of the effects

You can change the initial values (default values) of the effects in each mode (VT/Vocal/Guitar/Game). Use the following procedure.

1. Make sure that the UA-100 is connected to your computer.
2. Open the **Main** window of the UA-100 Controller.
3. On the front panel of the UA-100, rotate the Effect Type Selector to select an effect type. Effect assignments can be made for the four effect types VT/Vocal/Guitar/Game.
4. In the UA-100 Controller, click **[Effect Assign]**. The **Effect Assign** window will appear.
5. Set the default values of each parameter. Select the parameter that you wish to set, and use the slider located at the right to set the parameter value.
6. When you have finished making settings, click **[Assign Write]** to write the settings into the UA-100.
7. If you wish to return to the preset selections, click **[Preset]**.

Using the UA-100

This section explains basic operation of the UA-100 using a MIDI/Audio sequencing software and the UA-100 Controller. Before you read this, please read the Getting Started, connect the UA-100 to your computer, make settings, and install and set up the UA-100 Controller.

The explanation in this chapter assumes that you are using a sequencing software with MIDI/Audio recording functionality. Before you continue, please install your sequencing software and set it up.

** For details on the UA-100 Controller, refer to the UA-100 Controller Help.*

** For details on installing, setting up, and using your sequencing software, refer to the manual for your sequencing software.*

Recording Vocals

The UA-100 has two inputs to which a microphone can be connected, allowing you to record vocals or acoustic instruments.

Here we will explain how to connect a microphone to the UA-100 and use your sequencing software to record a vocal.

Connecting the Microphone

1 Before connecting a Microphone to the UA-100, lower the **Mic 1/ Guitar Input Volume** level.

2 When connecting a microphone, make sure that the Mic 1/Guitar function indicator is dark. If the Mic 1/Guitar indicator is lit, press the Mic 1/Guitar input knob.

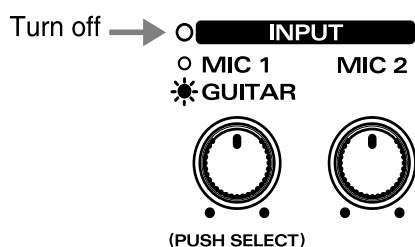

3 Connect your microphone to the UA-100's **Mic 1/Guitar Input Jack**.

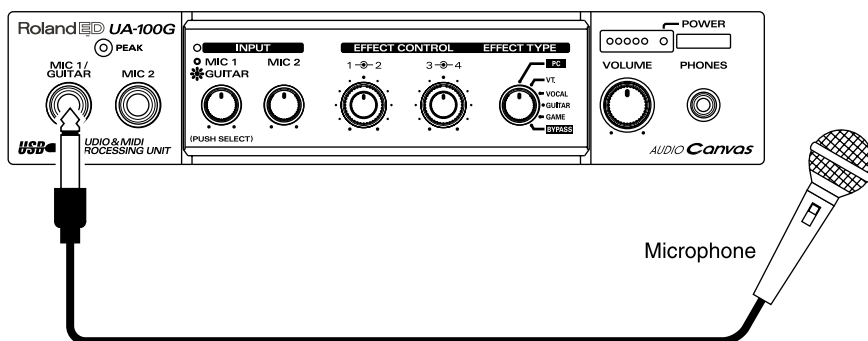

Depending on the location of the microphone and speakers, acoustic feedback (a high-pitched squeal) may be heard. If this occurs, take the following steps.

1. Change the direction of the microphone
2. Move the microphone away from the speaker
3. Lower the volume

MEMO

If the **Mic 1/Guitar Input Volume** is set for guitar input when a mic is being used, the audio level will be too low.

4

Set the UA-100's **Effect Type Selector** to the **[PC]** position.

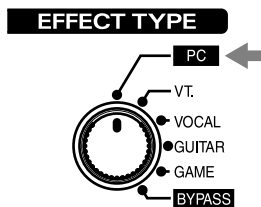

5

Start up the UA-100 Controller, and in the **Mixer** window, click the **easy setting** button for **[Use Mic 1]**.



Prepare for Recording

- 1 Start up your sequencing software, and open a new song.
- 2 Select **Roland UA-100 Wave** as the port for the audio track to be recorded.

If you are using a sequencer such as the Cakewalk series and need to select the source in the track, select either **Left 1:Roland UA-100 Wave** or **Right 1:Roland UA-100 Wave**.

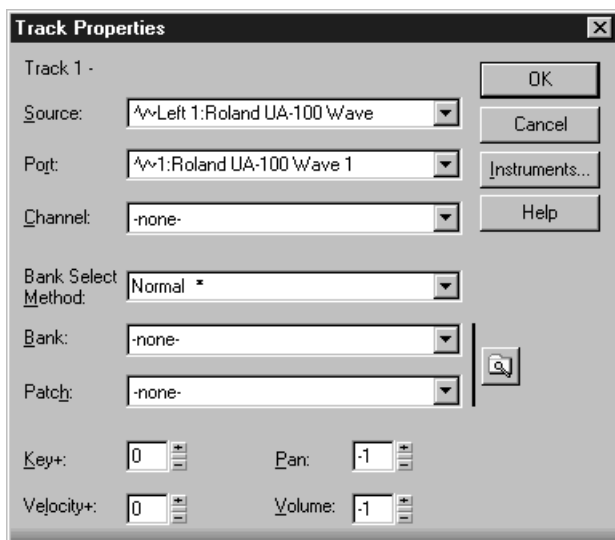

- 3 In your sequencing software, select the track to be recorded.
- 4 If your microphone has a switch, turn it on. Speak or sing into the microphone, and gradually rotate the **Mic 1/Guitar Input Volume** knob clockwise.

Make sure that the input level peak indicator lights in **green**. If it lights in **red**, the input level is too high. Adjust the Mic 1/Guitar Input Volume so that the level is as high as possible without causing the input level peak indicator to light in red.

NOTE

If **Roland UA-100 Wave** is not selected as the port for recording, the UA-100 has not been set correctly to the audio device of the sequencing software. For details on settings for the audio device, refer to the manual for your sequencing software.

5

On your sequencing software, check that the audio input level is not exceeding the maximum level. If it exceeds the maximum level, adjust the **Wave output slider** in the UA-100 Controller **Mixer** window so that the level is as high as possible without exceeding the maximum input level.

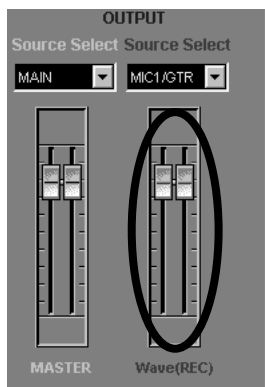

MEMO

For details on how to check the audio input level of your sequencing software, refer to the manual for your sequencing software.

Record and Playback

Rewind to the beginning of the song, and begin recording. When you finish recording, stop. Rewind to the beginning of the song, and play it back to hear the recorded data.

If you are using a sequencing software such as Cakewalk and have selected **Left 1:Roland UA-100 Wave** (or **Right 1:Roland UA-100 Wave**) as the source in the track, the played sound will be panned to the far left (or the far right). To place the sound in the center, use your sequencing software to adjust the pan of the track to the center. In the case of Cakewalk, click the pan field, and input "64."

Recording Guitar

The UA-100 provides an input for connecting an electric guitar.

Here's how to connect a guitar to the UA-100, and record it on your sequencing software.

Connecting the Guitar

- 1 Before you connect the guitar to the UA-100, lower the level of the **Mic 1/Guitar Input Volume**.
- 2 Make sure that the Mic 1/Guitar function indicator is **lit**. If the Mic 1/Guitar indicator is dark, press the Mic 1/Guitar Input Volume knob.

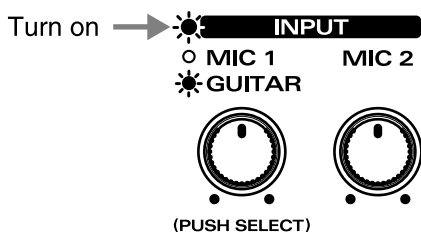

- 3 Connect your guitar to the UA-100's **Mic 1/Guitar Input Jack**.

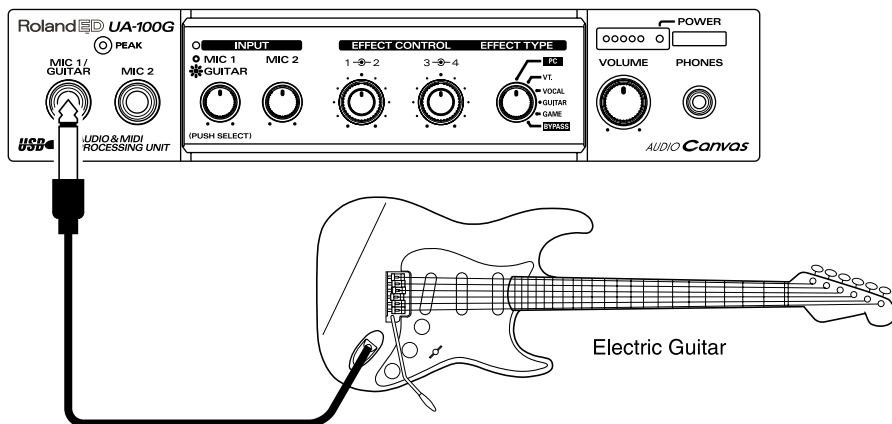

4

Set the UA-100's **Effect Type Selector** to the **[PC]** position.

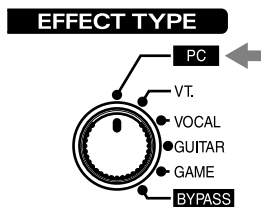

5

Start up the UA-100 Controller. In the **Mixer** window, click the **easy setting button** for **[Use Mic 1]**.



Prepare for Recording

- 1 Start up your sequencing software, and open a new song.
- 2 Select **Roland UA-100 Wave** as the port for the audio track that will be recorded.

If you are using a sequencer, such as one from the Cakewalk series, and need to select the source in the track, select either **Left 1:Roland UA-100 Wave** or **Right 1:Roland UA-100 Wave**.

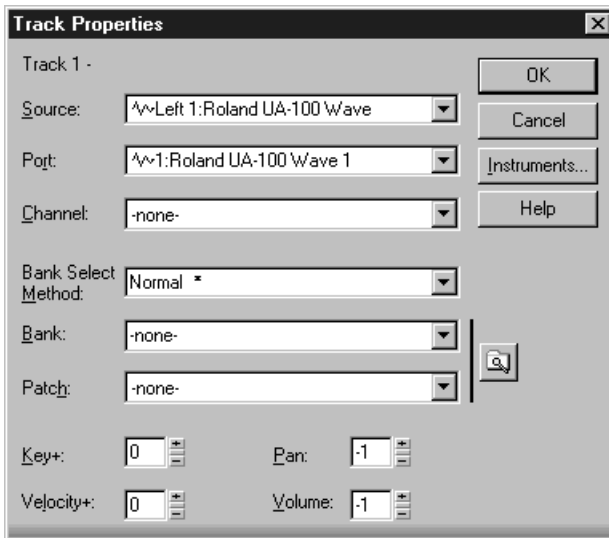

- 3 In your sequencing software, select the track to be recorded.
- 4 While playing your guitar, gradually rotate the **Mic 1/Guitar Input Volume** knob clockwise.

Make sure that the input level peak indicator lights in **green**. If it lights in **red**, the input level is too high. Adjust the Mic 1/Guitar Input Volume so that the level is as high as possible without causing the input level peak indicator to light in red.

NOTE

If **Roland UA-100 Wave** is not selected as the port for recording, the UA-100 has not been set correctly to the audio device of the sequencing software. For details on settings for the audio device, refer to the manual for your sequencing software.

5

On your sequencing software, check that the audio input level is not exceeding the maximum level. If it exceeds the maximum level, adjust the **Wave output slider** in the UA-100 Controller **Mixer** window so that the level is as high as possible without exceeding the maximum input level.

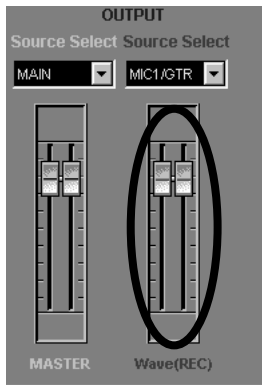

MEMO

For details on how to check the audio input level of your sequencing software, refer to the manual for your sequencing software.

Record

Rewind to the beginning of the song, and begin recording. When you finish recording, stop. Rewind to the beginning of the song, and play it back to hear the recorded data.

If you are using a sequencing software such as Cakewalk and have selected **Left 1:Roland UA-100 Wave** (or **Right 1:Roland UA-100 Wave**) as the source in the track, the played sound will be panned to the far left (or the far right). To place the sound in the center, use your sequencing software to adjust the pan of the track to the center. In the case of Cakewalk, click the pan field, and input "64."

Recording from an Audio Device

Not only a microphone or a guitar, but also the output of a MIDI sound module or audio device can be recorded into your computer via the line input jacks on the rear panel of the UA-100.

Here we will explain how the output of a MIDI sound module can be recorded via the line inputs of the UA-100 into your sequencing software as stereo audio data.

Connecting the Audio Device

- 1 Before you connect the MIDI sound module to the UA-100, lower the level of the line input (**INPUT VOLUME**).
- 2 Connect the audio output of your MIDI sound module to the **Line Input Jacks** of the UA-100.

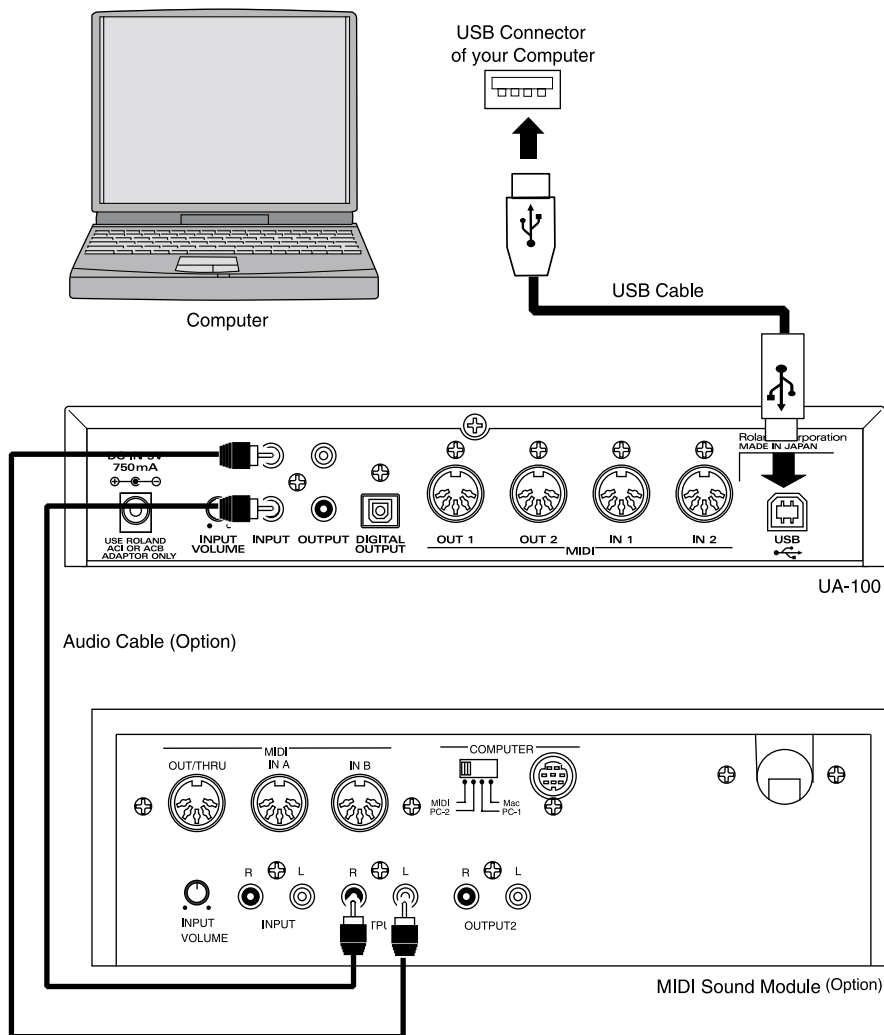

3

Set the UA-100's **Effect Type Selector** to the **[PC]** position.

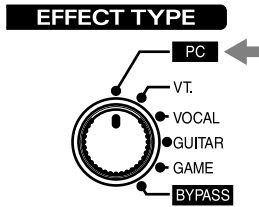
**4**

Start up the UA-100 Controller. In the **Mixer** window, click the **easy setting button** for **[Use Line]**.



Prepare for Recording

1 Start up your sequencing software, and open a new song.

2 Select **Roland UA-100 Wave** as the port for the audio track that will be recorded.

If the tracks of your sequencing software are monaural, prepare two tracks for stereo (L and R).

In the case of Cakewalk 8, make the following settings.

On a new track, double-click **Source** to access the **Track Properties** dialog box. Select **Left 1:Roland UA-100 Wave** as the **Source**, select **UA-100 Wave 1** as the **Port**, set **0** (zero) as the **Pan**, and click **[OK]**. Then on a different track, select **Right1: Roland UA-100 Wave** as the **Source**, select **UA-100 Wave 1** as the **Port**, set **127** as the **Pan**, and click **[OK]**. This will prepare a stereo track (two monaural tracks).

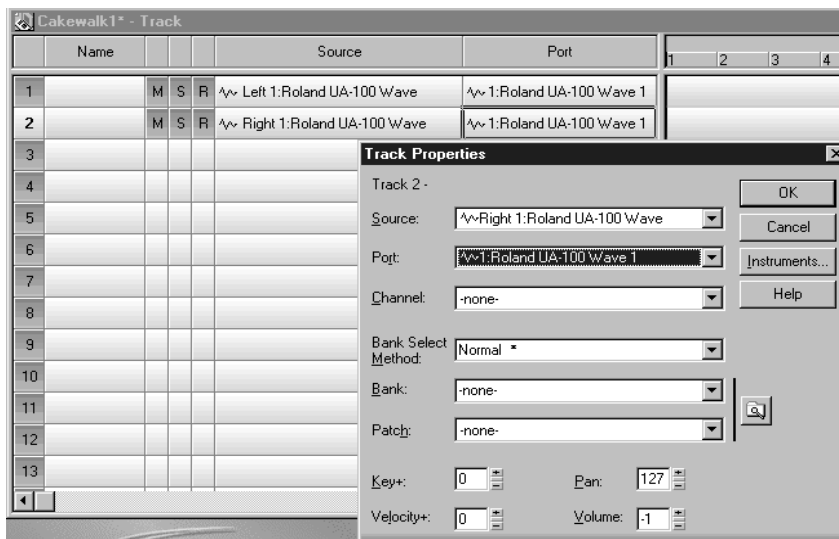

3 In your sequencing software, select the track to be recorded.

4 While playing back the device that is connected to the line inputs (in this case, your MIDI sound module), gradually rotate the **Line Input Volume** located on the rear panel of the UA-100 clockwise.

Make sure that the input level peak indicator lights in **green**. If it lights in **red**, the input level is too high. Adjust the output volume of your external MIDI sound module or the Line Input Volume of the UA-100 so that the level is as high as possible without causing the input level peak indicator to light in red.

NOTE

If **Roland UA-100 Wave** is not selected as the port for recording, the UA-100 has not been set correctly to the audio device of the sequencing software. For details on settings for the audio device, refer to the manual for your sequencing software.

5

On your sequencing software, check that the audio input level is not exceeding the maximum level. If it exceeds the maximum level, adjust the **Wave output slider** in the UA-100 Controller **Mixer** window so that the level is as high as possible without exceeding the maximum input level.

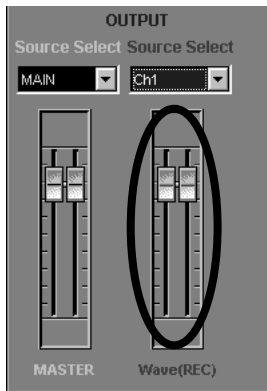

For details on how to check the audio input level of your sequencing software, refer to the manual for your sequencing software.

Record

Rewind to the beginning of the song, and begin recording. When you finish recording, stop. Rewind to the beginning of the song, and start playback to hear the recorded data.

Monitoring the Audio Data While You Record a New Part

Since the UA-100 has a variety of inputs that allow you to connect a source such as microphone, guitar, or MIDI sound module, you can record the sounds of many different instruments into your computer. In order to record these sources one after the other onto audio tracks of your sequencing software, you can use the UA-100 Controller to switch the input source.

Here we will explain the procedure for recording a new vocal in addition to the audio tracks of the existing sequence data. Use your sequencing software to open a song, and connect a microphone to the UA-100 as described in "Recording Vocals" (p. 20).

Selecting the Input Source

Start up the UA-100 Controller, open the **Mixer** window, and use the **Mic/Guitar select button** ❶ switch the input mode to the desired input source. For this example, we will select **Mic/Guitar** ❷. (When you click ❶, the ❷ display will change.)

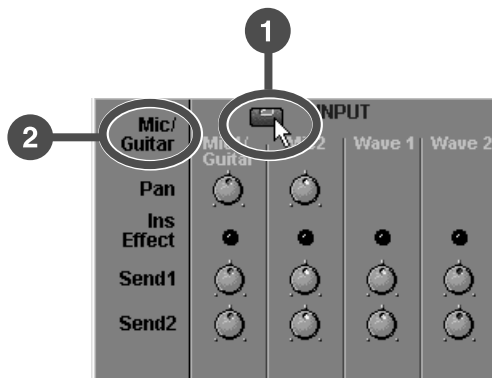

Select the Monitor Source

Use **Master Source Selector (Source Select: white)** to select the master source for monitoring. For this example, select **MAIN**.

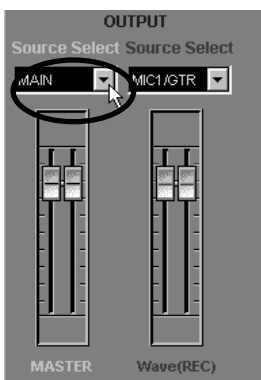

Select the Recording Source

Use **Wave Source Selector (Source Select: red)** to select the wave source for recording. For this example, select **MIC1/GTR**.

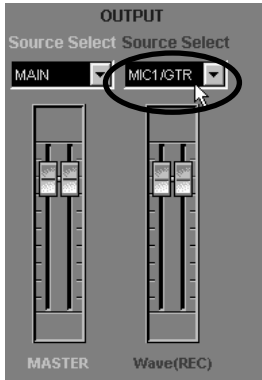

Prepare for Recording

Prepare to record the input source into the sequencing software. On the sequencing software, select the recording track, set the port, and adjust the audio input level.

If you are using Cakewalk, select **Audio Options** from the **Tools** menu. In the dialog box that appears, click the **Advanced** tab, and check **Enable Simultaneous Record/Playback** in the playback and recording section.

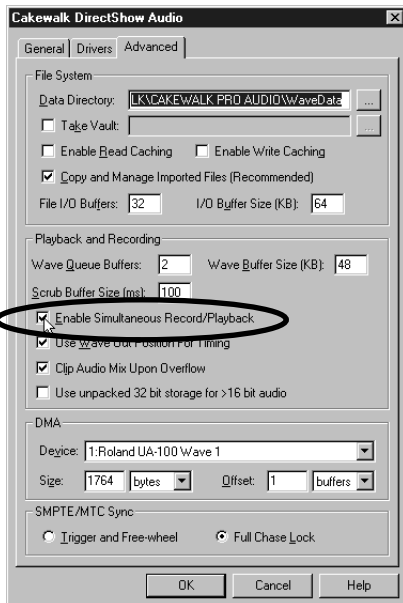

For details on recording preparations for each type of input source, refer to "Recording Vocals" (p. 20), "Recording Guitar" (p. 24), and "Recording from an Audio Device" (p. 28), as well as to the manual for your sequencing software.

Record and Playback

Now you can record while listening to the existing sequence data. Rewind to the beginning of the song, and begin recording. When you are finished recorded, stop.

Rewind to the beginning of the song, and play it back. Make sure that the previously existing audio data and the newly recorded audio data playback simultaneously.

Applying Effects While Playing Audio Data

The UA-100 lets you apply effects to the audio data as it plays.

Here we will apply an effect (the High Quality Reverb of Full Effects mode) to an audio track of the existing sequence data. Use your sequencing software to listen to the data beforehand.

Select the Monitor Source

Start up the UA-100 Controller, open the **Mixer** window, and use **Master Source Selector (Source Select: white)** to select the master source for monitoring. For this example, select **MAIN**.

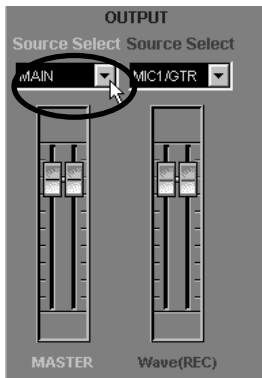

Select the Effect Mode

Use the **Effect Mode Selector** to select the effect mode. For this example, select **Full Effects Mode**.

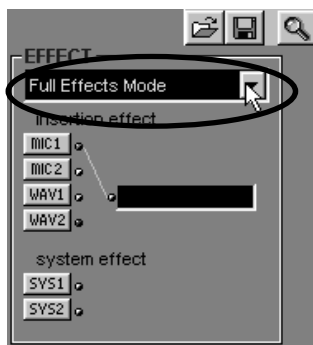

Select the Effect Source

Click the **Effect Select** button, and the window for the effect mode selected by **Effect Mode Selector** will appear. In this example, click [SYS 1] to open the **Full Effects** window.

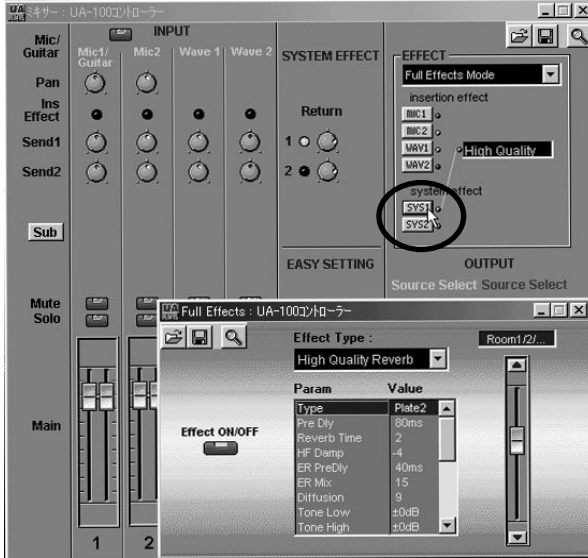

Make Effect Settings

While producing sound from the input source, set the **Effect Type**, parameter (**Param**), and **Value**. For this example, select **High Quality Reverb**, and adjust the various parameters while the audio data plays back.

To adjust the amount of effect that is applied, use the **Send 1 Controller** and the **Return Controller**.



Try adjusting the various parameters so that the sound is to your liking. Can you hear the effect being applied?

MEMO

For details on effect parameters, refer to appendix "Effect Parameters Chart" (p. 66). For details on making effect settings, refer to the UA-100 Controller Help and to the Reference Manual.

MEMO

For details on the **Send 1 Controller** and **Return Controller**, refer to "Using Multiple Effects Simultaneously" (p. 50)

Applying Effects While You Record

You can apply the internal effects of the UA-100 while you record onto your computer. When the UA-100 is connected to your computer, you can use the UA-100 Controller to control the internal effects.

Here we will explain how to select a guitar as the input source, and apply an effect (the "Distortion" effect of Compact Effects Mode) while you record onto your sequencing software. First start up your sequencing software, and connect your guitar to the UA-100 as described in "Recording Guitar" (p. 24).

Select the Input Source

Start up the UA-100 Controller, open the **Mixer** window, and use the **Mic/Guitar select button ①** to switch the input mode so that the desired input source is selected. For this example, select **Mic/Guitar ②**. (When you click ①, the ② display will change.)

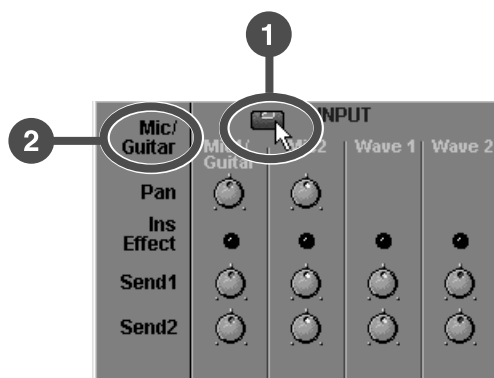

Select the Monitor Source

Use **Master Source Selector (Source Select: white)** to select the master source for monitoring. For this example, select **MAIN**.

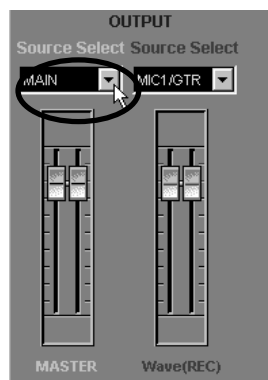

Select the Recording Source

Use **Wave Source Selector (Source Select: red)** to select the wave source for recording. For this example, select **Ch1**.

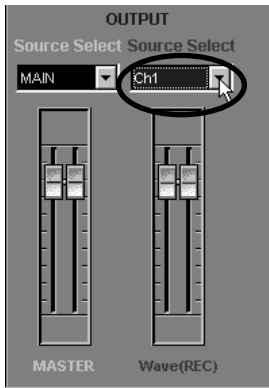

Select the Effect Mode

Use **Effect Mode Selector** to select the effect mode. For this example, select **Compact Effects Mode**.

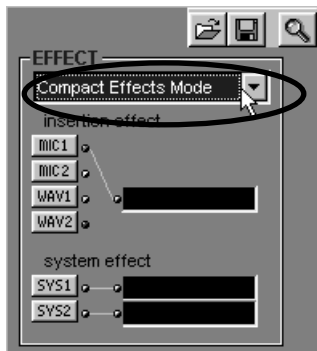

Select the Effect Source

Click the **Effect Select** button, and a window will appear for the effect mode that was selected by **Effect Mode Selector**. In this example, clicking **[MIC 1]** will open the **Compact Effects** window.

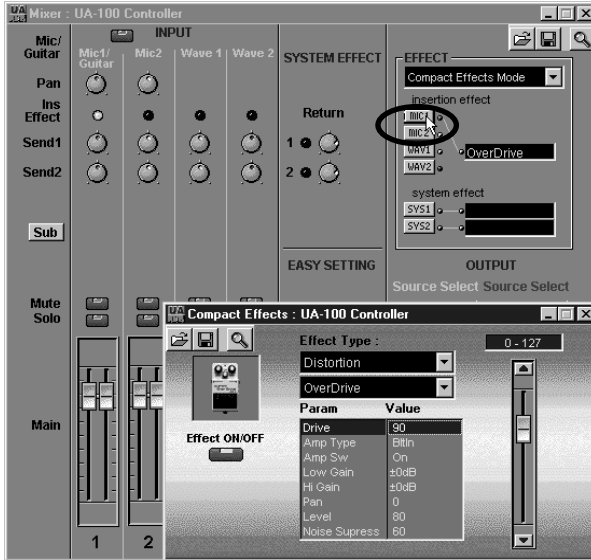

Make Effect Settings

While producing sound on the input source, set the **Effect Type**, parameter (**Param**), and **Value**. For this example, select **Distortion**, and play your guitar while adjusting the parameters to change the sound to your liking. Can you hear the effect being applied?



For details on effect parameters, refer to appendix "Effect Parameters Chart" (p. 66). For details on making effect settings, refer to the UA-100 Controller Help and to the Reference Manual.

Prepare for Recording

Prepare for recording from the input source onto your sequencing software. On your sequencing software, select the recording track, set the port, and adjust the audio input level.



For details on preparations for various input sources, refer to "Recording Vocals" (p. 20), "Recording Guitar" (p. 24), and "Recording from an Audio Device" (p. 28), as well as to the manual for your sequencing software.

Record and Playback

Rewind to the beginning of the song, and begin recording. When you finish recording, stop.

Rewind to the beginning of the song, and play it back to hear the recorded data. Verify that the sound processed by the specified effect was recorded.

Adjusting the Output Level

If the output sounds as though it is distorted, even though the **input level peak indicator** lit **green** while the audio signal was being input, use the following procedure to find the problem.

1. Were you using the Compressor, Overdrive, Distortion, Enhancer, or Lo-Fi effect? These effects will produce distortion.
2. Watch the **output level indicator** of the UA-100. If the far right LED is lit red, use the UA-100 Controller to lower the **master output fader** or turn down the front panel **Line Output Volume (VOLUME)** so that the red LED does not light.
3. Try switching the effect on/off. If the sound is distorted when the effect is **on**, try lowering the input fader in the UA-100 Controller **Mixer** window.

If the sound is still distorted, check the output level of the device that is connected to the output of the UA-100.

Monitoring the Effect Sound While You Record the Unprocessed (Dry) Sound

By using the UA-100's routing function, you can monitor the sound processed by the effect while you record the unprocessed (dry) sound. It is often convenient to record the dry sound, since you will then be able to try various effect settings during playback, and make fine adjustments to the effects as many times as desired.

Here we will explain how to apply an effect to the input source (a vocal, in this case), while you record the dry sound into your sequencing software. First start up your sequencing software, and connect a microphone to the UA-100 as described in "Recording Vocals" (p. 20).

Select the Input Source

Start up the UA-100 Controller, open the **Mixer** window, and use the **Mic/Guitar select button ①** to switch the input mode to the desired input source. For this example, select **Mic/Guitar ②**. (When you click ①, the ② display will change.)

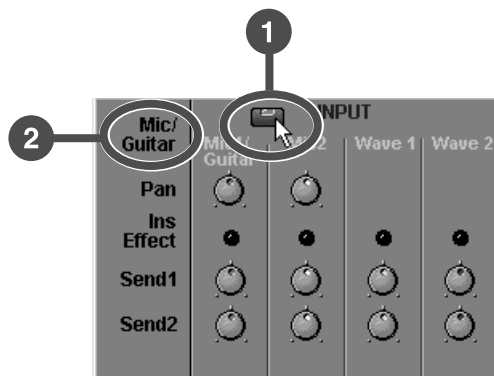

Select the Monitor Source

Use **Master Source Selector (Source Select: white)** to select the master source for monitoring. For this example, select **MAIN**.

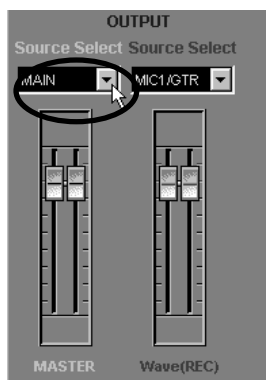

Select the Recording Source

Use **Wave Source Selector (Source Select: red)** to select the wave source that will be recorded. For this example, select **MIC1/GTR**.

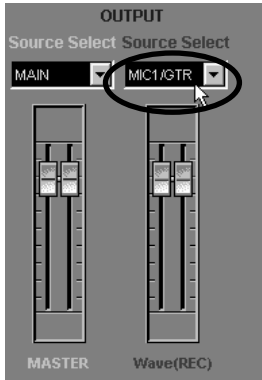

Select the Effect Mode

Use the **Effect Mode selector** to select the effect mode. For this example, select **Full Effects Mode**.

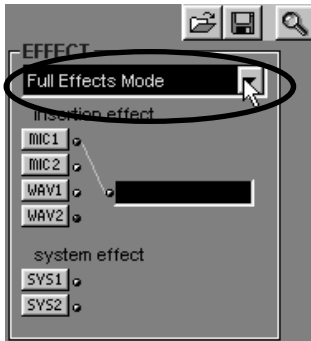

Select the Effect Source

Click the **effect select button**, and a window will open for the effect mode you selected with the **Effect Mode selector**.

In this example, clicking **[MIC 1]** will open the **Full Effects** window.

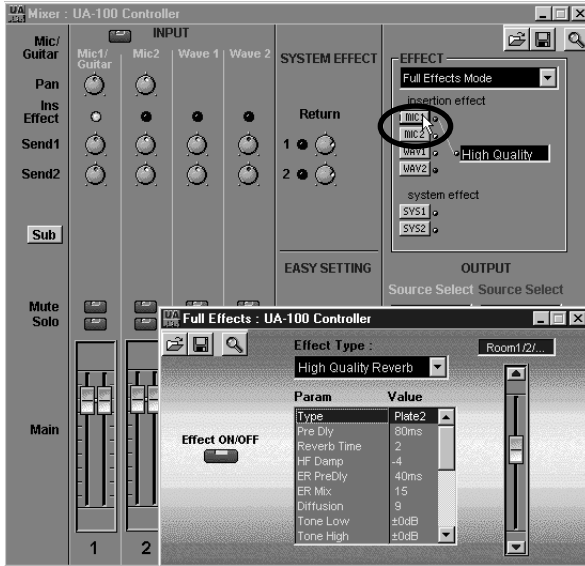

Make Effect Settings

While producing sound on the input source, set the **Effect Type**, parameter (**Param**), and **Value**. Set the parameters while you apply the effect (in this example, the settings of the **Full Effects** window will be used) to the vocal.



For details on effect parameters, refer to appendix "Effect Parameters Chart" (p. 66). For details on making effect settings, refer to the UA-100 Controller Help and to the Reference Manual.

Prepare for Recording

Prepare for recording the input source into your sequencing software. On your sequencing software, select the track for recording, set the port, and adjust the audio input level.



For preparations to record various input source, refer to "**Recording Vocals**" (p. 20), "**Recording Guitar**" (p. 24), and "**Recording from an Audio Device**" (p. 28), as well as to the manual for your sequencing software.

Record and Playback

Rewind to the beginning of the song, and begin recording. When you finish recording, stop.

Rewind to the beginning of the song, and play it back to hear the data you recorded. Verify that the sound unprocessed by the effect (i.e., the dry sound) was recorded on the track.

Re-recording Audio Data While Applying an Effect

You can playback a previously-recorded track of audio data while applying a UA-100 effect, and re-record the result. This makes it possible to apply an effect to audio data that was recorded without effect processing (dry).

Here we will explain the procedure for applying an effect to an audio track of the existing sequence data, and re-record it on a different track. Before you begin, open the data in your sequencing software.

Select the Monitor Source

Start up the UA-100 Controller, open the **Mixer** window, and use **Master Source Selector (Source Select: white)** to select the master source for monitoring. For this example, select **MAIN**.

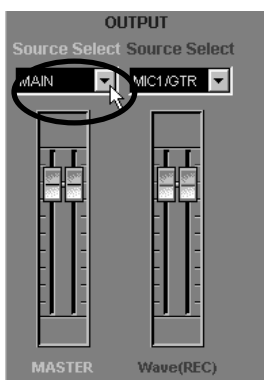

Select the Recording Source

Use **Wave Source Selector (Source Select: red)** to select the wave source that will be recorded. For this example, select **Ch3**.

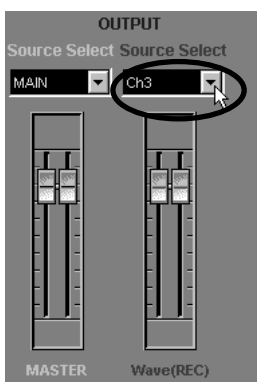

NOTE

If Roland UA-100 Wave 2 is selected as the port for the existing audio data, select **Ch4**.

Select the Effect Mode

Use the **Effect Mode selector** to select the effect mode. For this example, select **Full Effects Mode**.

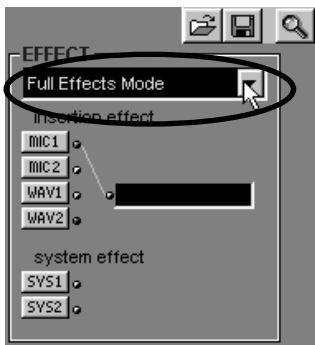

Select the Effect Source

Click the **effect select button**, and a window will open for the effect mode you selected with the **Effect Mode selector**.

In this example, clicking [WAV 1] will open the **Full Effects** window.



If Roland UA-100 Wave 2 is selected as the port for the existing audio data, click [WAV 2].

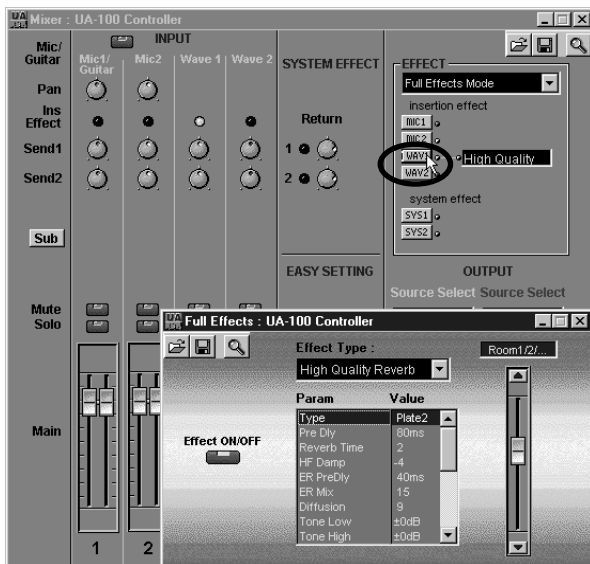

Make Effect Settings

While producing sound on the input source, set the **Effect Type**, parameter (**Param**), and **Value**. Set the parameters while you apply the effect (in this example, the settings of the **Full Effects** window will be used) to the audio data.



For details on effect parameters, refer to appendix "Effect Parameters Chart" (p. 66). For details on making effect settings, refer to the UA-100 Controller Help and to the Reference Manual.

Prepare for Recording

Prepare for recording into your sequencing software. On your sequencing software, select the track for recording, set the port, and adjust the audio input level.



For details on preparations for recording, refer to the manual for your sequencing software.

If you are using Cakewalk, press the Arm button (R) for each track to turn it off for tracks that will playback audio data, and turn it on (red) for the tracks that will record this data. Also, go to the **Tools** menu, select **Audio Options**, click the **Advanced** tab in the dialog box that appears, and check **Enable Simultaneous Record/Playback** in the recording and playback section.

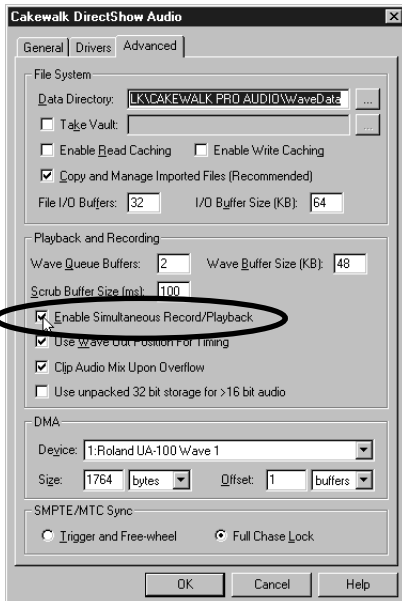

Record

Rewind to the beginning of the song, and begin recording. When you finish recording, stop.

Turn the Effect Off

Since an effect has already been applied to the recorded data, you will need to turn off the currently specified effect before you playback. In the window that you opened in "Select the Effect Source" (p. 47) (the **Full Effects** window in this case), click the **effect switch** to make it dark.

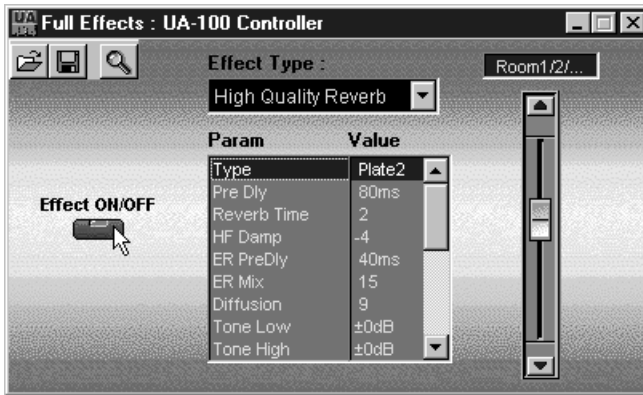

Playback

Rewind to the beginning of the song. Mute the original audio track, and play it back the newly recorded audio data. The recorded data will be played back with the effect (in this case, High Quality Reverb).

Using Multiple Effects Simultaneously

The UA-100 lets you use a total of three effects simultaneously: one of 64 different compact effects (insertion effects), and two system effects. By taking advantage of this capability, you can do things such as applying an effect such as distortion to a guitar while applying reverb or chorus to the overall mix.

Here we will explain how you can apply an effect to the existing audio data played by your sequencing software, and simultaneously apply an insertion effect to a guitar connected to the UA-100. Before you begin, open the song data in your sequencing software, and connect your guitar to the UA-100 as described in "Recording Guitar" (p. 24).

Select the Input Source

Start up the UA-100 Controller, open the **Mixer** window, and use the **Mic/Guitar select button ①** to select the input source. For this example, select **Mic/Guitar ②**. (When you click ①, the ② display will change.)

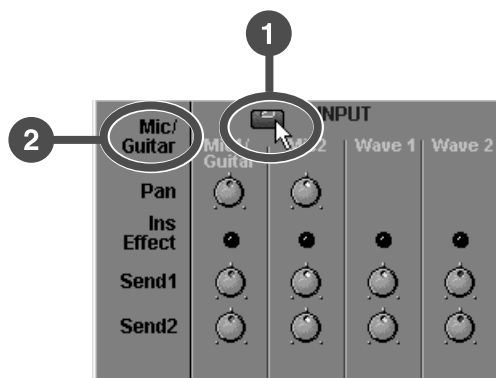

Select the Monitor Source

Use **Master Source Selector (Source Select: white)** to select the source for monitoring. For this example, select **MAIN**.

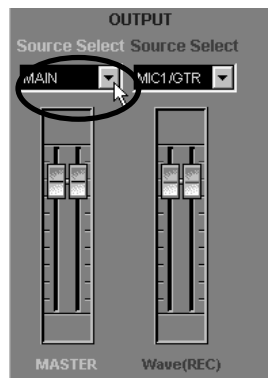

Select the Effect Mode

Use the **Effect Mode selector** to select the effect mode. For this example, select **Compact Effects Mode**.

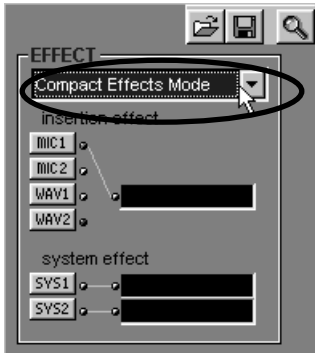

Select the Effect Source

Use the **effect select button** to select the source to which the effect will be applied. Click the button, and the window will open for the effect mode you selected with the **Effect Mode selector**.

For this example, click **[MIC1]** to select the **Compact Effects** window, and click **[SYS1]** and **[SYS2]** to open the **System Effect1** and **System Effect2** windows respectively.

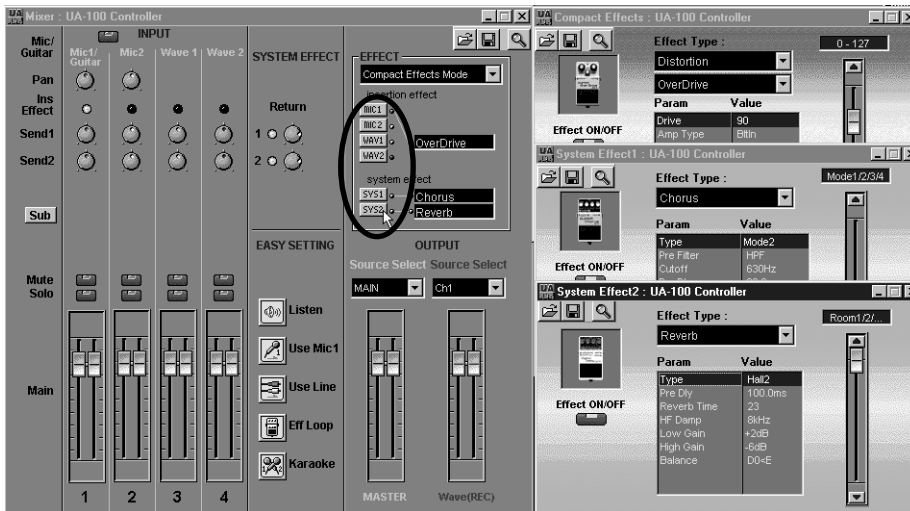

Make Effect Settings

1

While playing sound on the input source, use the **Compact Effects** window to set the **Effect Type**, parameter (**Param**), and **Value**. In this example, apply the insertion effect to the guitar (the settings of the **Compact Effects** window will be used) as you adjust the parameters.

Then use the **System Effect1** and **System Effect2** windows to set the **Effect Type**, parameter (**Param**), and **Value**. In this example, make settings for the system effects to be applied to the audio data (the settings of the **System Effect1** and **System Effect2** windows will be used).

2

To adjust the amount of system effects that are applied, use the **Send 1 Controller**, **Send 2 Controller**, and **Return Controller**.

Use the mouse to click and drag the **Wave 1 Send 1 Controller** or **Send 2 Controller** or the **Return Controller**, to rotate them clockwise. This will cause the effects specified in the **System Effects1** and **System Effects2** windows to be applied to the existing audio data.

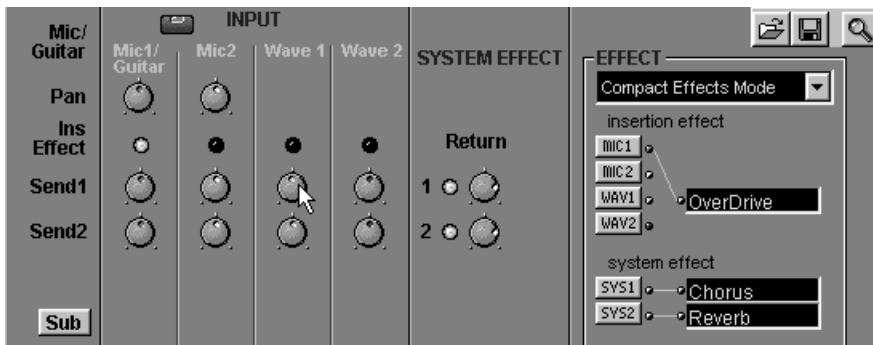

If Roland UA-100 Wave 2 is selected as the port for the existing audio data, adjust the **Send 1 controller** or **Send 2 controller** for Wave 2.

The **Send 1 Controller** and **Send 2 Controller** adjust the levels at which the sound of each input source are sent to the system effects **System Effect 1** and **System Effect 2**. The **Return Controller** adjusts the level at which the sound from the system effect is returned. As you set the Effect Type and effect parameters to your liking, use these controllers to adjust the amount of each effect.

3

Although the **Compact Effect** is already applied to the guitar, you can adjust the **Send 1 controller** and **Send 2 controller** of **Mic 1/Guitar** and the **Return Controller** to apply system effects to it as well.

MEMO

For details on effect parameters, refer to appendix "Effect Parameters Chart" (p. 66). For details on making effect settings, refer to the UA-100 Controller Help and to the Reference Manual.

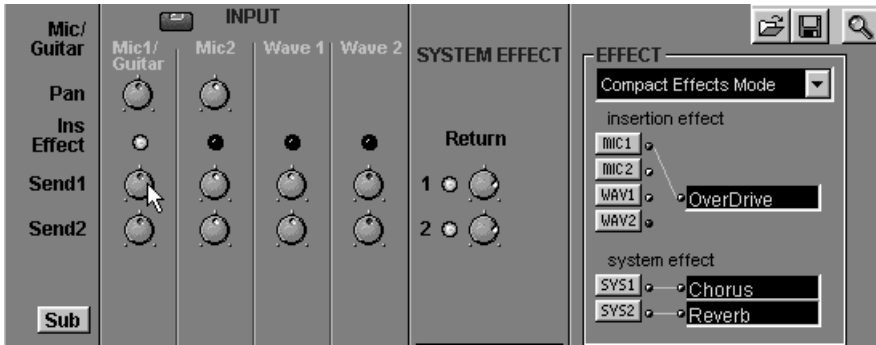

Adding Harmony to a Vocal

The UA-100 contains a VT (Voice Transformer) effect. By allowing you to independently control the basic pitch and the formants, this effect can transform a female voice into a male voice or vice versa, or create a variety of vocal characters.

Here we will explain how a harmony can be applied to a vocal, and recorded. Before you begin, connect a microphone to the UA-100 as described in "Recording Vocals" (p. 20).

MEMO Formants

An important element in determining the character of a voice. They are fixed frequency regions of emphasis that depend on the shape of the vocal cords and throat.

Start up the Voice Transformer Mixer

Start up the UA-100 Controller, and in the **Main** window, click [VT Mixer]. The **Voice Transformer** mixer will start up.



Select the Input Source

Click the **Mic/Line** select button to select the input source. For this example, select **MIC**. At the same time, turn on the **MIC 1 Effect** select button (**Effect**).

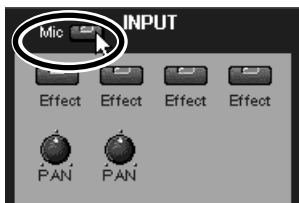

Make Settings for the Voice Transformer Function

We will set the Vocal 1 part slightly higher than your own voice. Set the Vocal 1 **pitch controller select button** to **Manual**, set the **Pitch Controller** to **700**, and finally set the **level fader** to **100**.

Then, set the Vocal 2 part slightly lower than your own voice. Set the Vocal 2 **pitch controller select button** to **Manual**, set the **pitch controller** to the **-500**, and finally set the **level fader** to **100**.

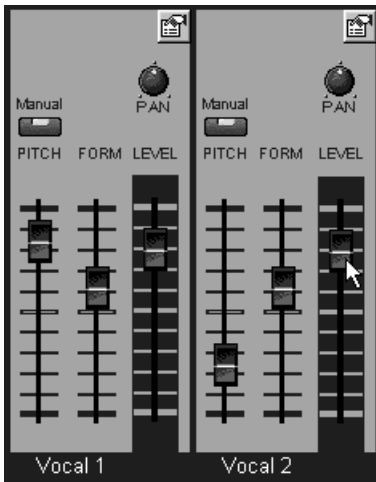

Make Effect Settings

1

For the System effect, you can set parameter (**Param**) and **Value** to make detailed settings for the effect. Here we will not make any particular settings, but will set the direct level fader (**DIRECT LEVEL**) to **100** so that the sound unprocessed by the pitch controller will be combined with the output.

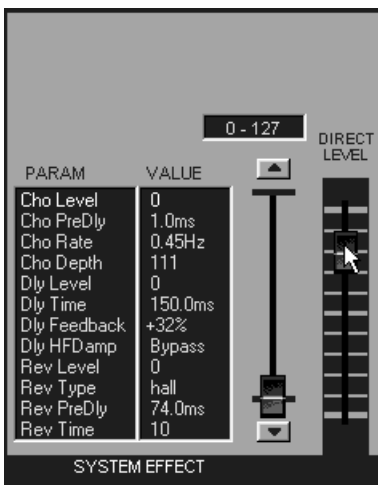

2

Now try singing a chorus part. Do you hear your own voice together with a slightly higher and a slightly lower version of it all sounding together? If the chorus sounds like a robot, move the formant controllers (**FORM**) for Vocal 1 and Vocal 2 to adjust the sound appropriately.

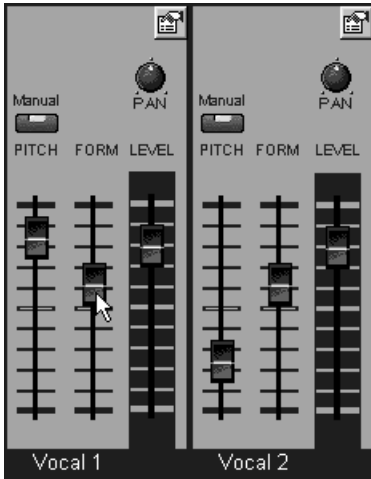

Prepare to Record

Make preparations to record on your sequencing software. Set the recording level, select the track for recording, and select the port.

MEMO

For details on preparations for recording, refer to the manual for your sequencing software.

Record and Playback

Rewind to the beginning of the song, and begin recording. When you finish recording, stop. Rewind to the beginning of the song, and play it back to hear the recorded data.

Using the UA-100 as a MIDI Interface

The UA-100 functions not only as an audio device, but also as a 2IN/2OUT MIDI interface. This means that you can connect MIDI equipment without using a separate MIDI interface.

Here's how you can connect a MIDI keyboard to the UA-100, and record your playing on your sequencing software.

Connect Your MIDI Instrument

Connect your **MIDI keyboard** to the UA-100's **MIDI IN 1**, and your **MIDI sound module** to **MIDI OUT 1**.

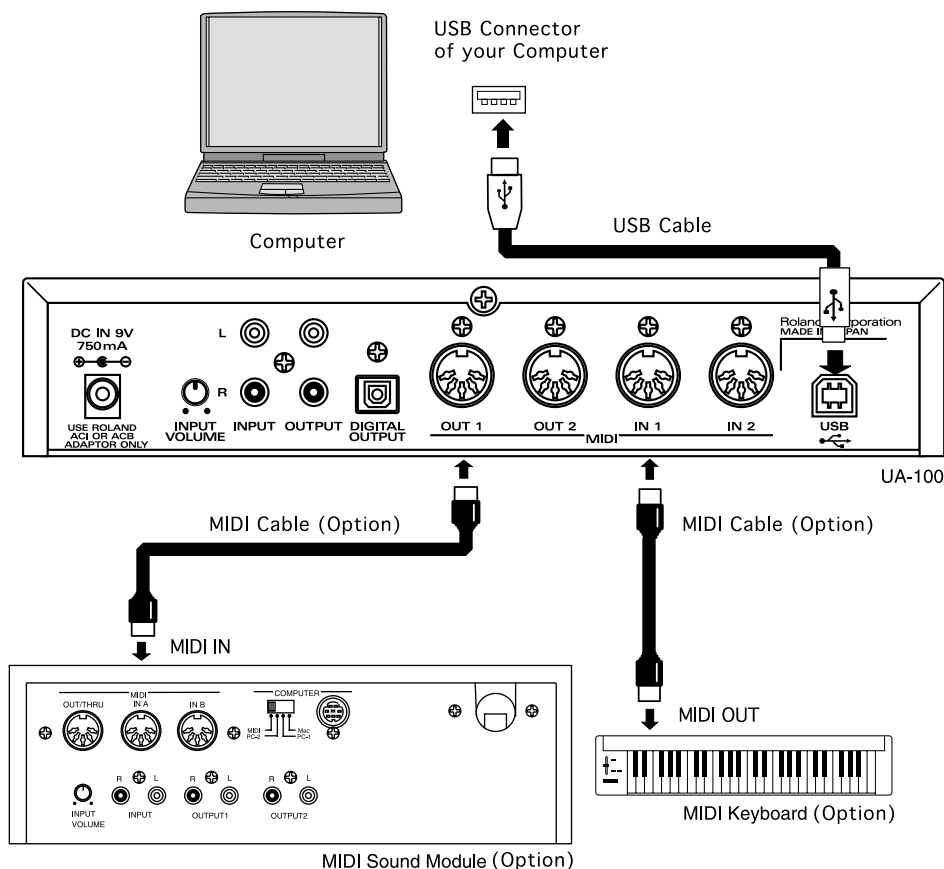

Record MIDI Data

- 1** Start up your sequencing software.
- 2** On your sequencing software, specify the track that will be used for recording, and set the source so that MIDI data can be recorded. With some sequencing software, the tracks that allow audio data or MIDI data to be recorded may already be pre-specified, making this step unnecessary.
- 3** As the MIDI port for the track to be recorded, select **Roland UA-100 MIDI 1**. For details on selecting the MIDI port in your sequencing software, refer to the manual that came with the software.
- 4** Begin recording, and play your MIDI keyboard.
- 5** When you finish your performance, stop recording.

Using MIDI Messages to Control the UA-100

The digital mixer inside the UA-100 can be controlled using MIDI messages.

Here we will explain how MIDI messages can adjust the volume of the audio track of existing sequence data. Before you continue, open a song in your sequencing software.

Settings on Your Sequencing Program

1

Select an unused track on your sequencing software, and set it so that MIDI messages (control changes) can be input into the track.

2

As the MIDI port of the track you will input, select **1:Roland UA-100 MIDI Control**.



For details on settings for your sequencing software, refer to its manual.

Input MIDI Messages

Input MIDI messages into your sequencing software.

Here we will use MIDI messages to adjust the master output volume of the UA-100. Since the volume of the UA-100 can be controlled by MIDI Volume messages (controller number 7), we will input control change messages for controller number 7 into the sequencing software.

Volume messages can be transmitted on different MIDI channels to control various volume levels within the UA-100. Here we want to control the volume of the master output, so we will use MIDI channel 16.

The correspondence between the various UA-100 levels and MIDI channels is shown below.

MIDI channel	Source
Ch.1	LINE (line mode) : Line input MIC1 (mic mode) MIC1 (mic mode): Mic 1/Guitar input MIC1MIC2 (Mic 1 + Mic 2 mode): Mic 1/Guitar input and Mic 2 input
Ch.2	MIC2 (Mic mode only): Mic 2 input
Ch.3	WAVE1: Input from the audio output device Roland UA-100 Wave 1
Ch.4	WAVE2: Input from the audio output device Roland UA-100 Wave 2
Ch.15	WAVE (Rec): Output to the audio input device Roland UA-100 Wave
Ch.16	LINE(Master): Output to the line outputs, headphones, and digital output

Make settings so that the MIDI controller data is transmitted on the MIDI channel that corresponds to the source you wish to control.

Playback

Rewind to the beginning of the song, and listen to the sequence data. Notice that the volume will change for the UA-100 level that corresponds to the MIDI channel you used in "**Input MIDI Messages**" (p. 59).

Many other MIDI messages can be used to control the settings of the UA-100. For details refer to the Reference Manual and the MIDI Implementation.

Digitally Recording to MD/DAT

The UA-100 is able to mix two audio devices from the computer and two mic inputs or one pair of line inputs, and output the result from its digital output connector.

Here we will explain how you can playback existing sequence data, and record from the UA-100's digital output onto a digital recorder such as MD or DAT. Before you continue, open the song data in your sequencing software.

Connecting the MD or DAT

Connect the digital output connector of the UA-100 to the digital input connector of your MD or DAT digital recorder.

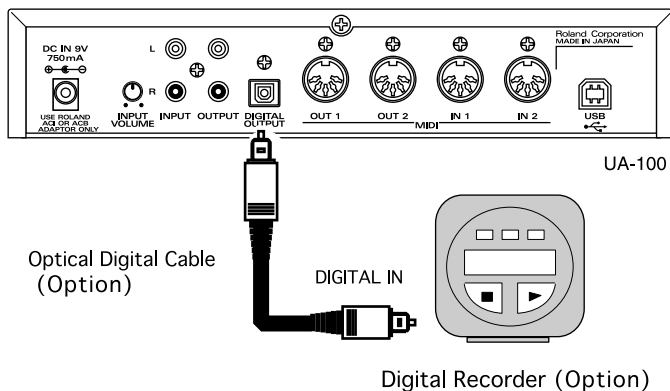

MEMO

An optical digital cable is not included. Take note of the shape of the connector for the device you wish to connect, and purchase the appropriate cable.

Record

1

Prepare for recording on your digital recorder. Start recording on your digital recorder, and start playback on your sequencing software.

2

When you have finished recording, stop the digital recorder and sequencing software.

The volume that is output from the UA-100's digital output connector is controlled from your computer. To adjust it, use either the Windows volume control, or the master output fader of the UA-100 Controller mixer or VT mixer window.

* If the UA-100 Controller mixer or VT mixer function is in Mic Input mode, the audio signal from the line input jacks cannot be output digitally. For details refer to appendix "Internal Blocks of the UA-100" (p. 64).

■ Copyright protection mode

By using this mode, you can prohibit digital copying of an original song that was digitally recorded from the UA-100 onto MD or DAT. Use the following procedure.

1. From the **Setting** menu of the UA-100 Controller, select **System Setting**. The **Setting** dialog box will appear.
2. Click the **System** tab, check **Copyright in Digital Out**, and click **[OK]**.

Appendices

This section contains a variety of information that you should find useful. When you wish to learn more about the UA-100, you can refer to the internal block diagram, effect parameter list, and MIDI implementation that are provided here.

Internal Block Diagram of the UA-100

About the Block Diagram

When the UA-100's Effect Type Selector is in the [PC] position, the UA-100 Controller can be used to freely rearrange the internal blocks. Here we will explain how to use the block diagram of the UA-100 Controller to specify the signal flow of the UA-100.

In the UA-100 Controller **Mixer** window, pressing the **magnifying glass button**  will open the **Block Diagram**.

In the block diagram, the flow of signals within the UA-100 moves from left to right.

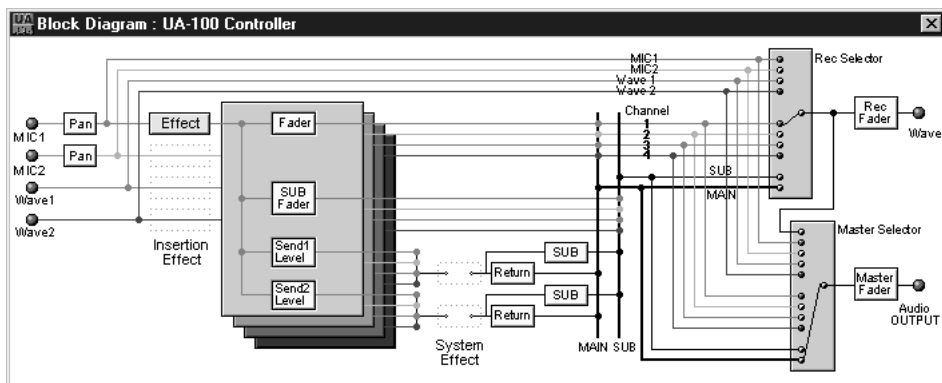

At the right are two gray boxes. The upper box corresponds to the **wave source selector (Source Select: red)**, and the lower box to the **master source selector (Source Select: white)**. The signal to be recorded and the signal to be monitored (the monitor source) can be selected independently.

Most audio engineers usually record without applying effects (dry), so that the song can be remixed or the current mix modified. For example, if a vocal is recorded with reverb that produces the impression of singing in a concert hall, it will be impossible to remove the reverb. However if the vocal is recorded dry, the effect can be changed later.

However, the vocalist may prefer to hear an effect applied to their voice (wet) as they sing. If you understand the signal routing in this block diagram, you will be able to set the recorded sound and monitored sound independently.

Using the Block Diagram

As an example, we will assume that a microphone is being used, and explain how the block diagram can be used to route the input and output signals. Before you begin, start up the UA-100 and arrange the windows so that you can easily see both the **Mixer** window and the block diagram.

In the UA-100 Controller **Mixer** window, pressing the **magnifying glass button**  will open the **Block Diagram**.

1

In the **Mixer** window, click the **easy setting button** for **Use Mic 1**.

2

In the block diagram, left-click the gray box marked **Rec Selector**. Click it again, and the thin black line inside the box will move. This line indicates the channel that will actually be recorded.

A) The first four channels (i.e., **MIC 1**, **MIC 2**, **Wave 1** and **Wave 2**) are connected directly from the input to the Rec Selector. If the thin black line in the Rec Selector box is connected to one of these, the sound unprocessed by the effect (dry sound) will be recorded.

B) Below these channels are four other channels. These channels are not connected directly to the Rec Selector, but pass through the Insertion Effect and are then connected to the Rec Selector. If the thin black line in the Rec Selector is set to one of these channels, the sound of the Insertion Effect applied to the input will be recorded.

C) If the final channel, MAIN, is selected, the sound of all inputs mixed will be recorded with all effects applied (Insertion Effect + System Effect).

3

The other gray box marked Master Selector will function in the same way as Rec Selector. However when this is changed, it does not affect the signal recorded on the sequencing software, but will affect the sound that is heard from the monitor speakers (the line output of the UA-100).

All changes made in the block diagram will be reflected in the Mixer window. Similarly, all changes made in the Mixer window will be reflected in the block diagram.

Internal Blocks of the UA-100

When the UA-100's Effect Type Selector is in the [PC] position, the UA-100 Controller can be used to freely rearrange the internal blocks. However in cases other than [PC] (i.e., [VT], [VOCAL], [GUITAR], [GAME], [BYPASS]), the internal blocks of the UA-100 will be rearranged depending on the selected mode.

In each operating mode, the internal blocks of the UA-100 will be as shown below. For details on the block diagrams, refer to "Analog Mixer" and "Digital Mixer" in the Reference Manual.



For details on the internal blocks and signal flow for **PC mode**, refer to "About the Block Diagram" (p. 62).

■ VT Mode

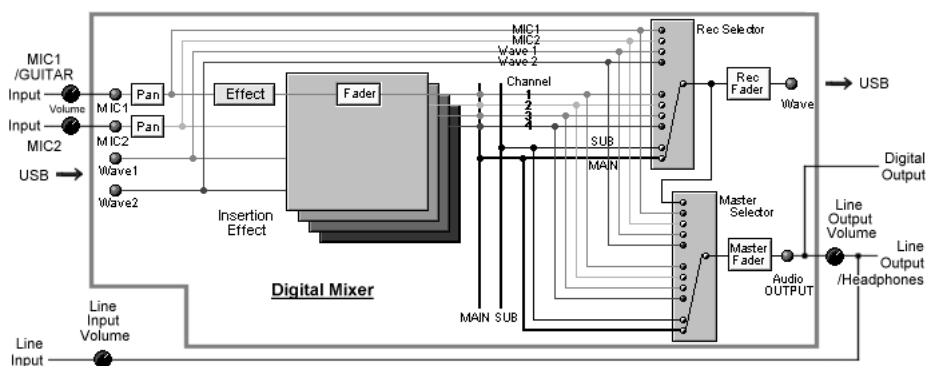

■ VOCAL and GUITAR Modes

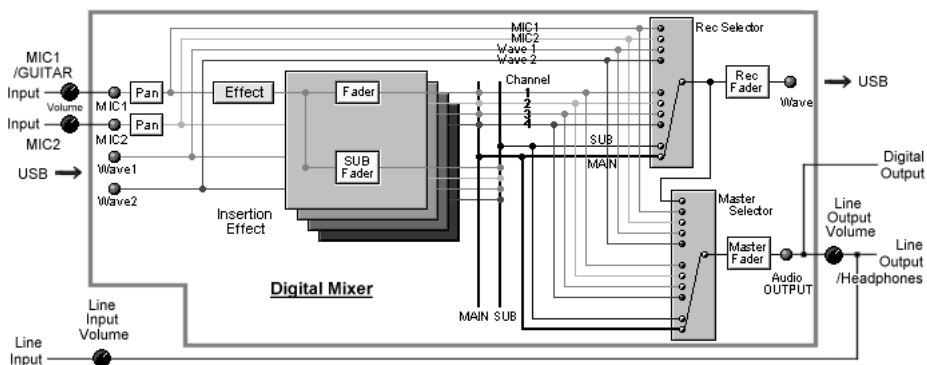

■ GAME Mode

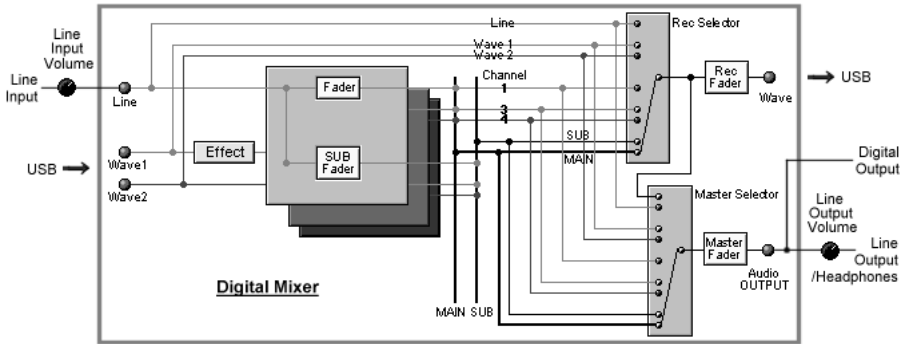

■ BYPASS Mode

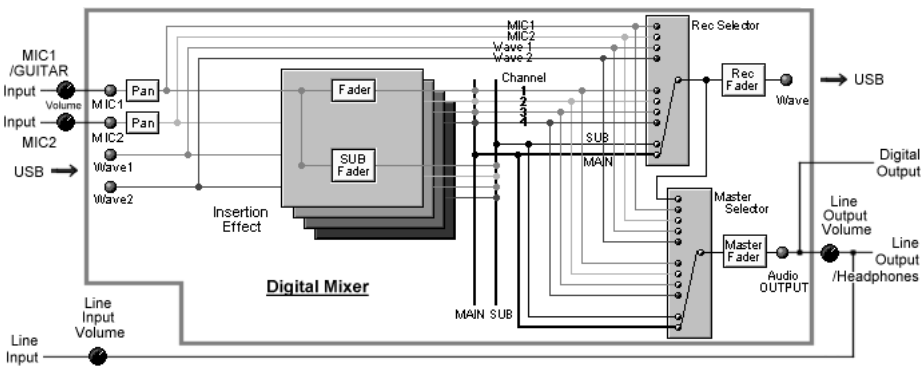

Effect Parameters Chart

< Effect Parameters Chart >

Parameter	Setting Value	Value(Hex.)	MSB/LSB(H)
01 : Stereo-EQ			01
00			
Low Freq	200/400	00/01	03

• Setting Value

This shows a list or range of values you can set for the parameter. Values in bold type are the parameter's default value.

• Value (Hex.)

This is the value, in hexadecimal format, that is actually sent to the UA-100 in correspondence with the Setting Value. For items marked by an asterisk (**), the correspondences between the hexadecimal value and the Setting Value appear in "Effect Parameter Conversion Table" (p. 74).

*1: Pre Delay Time	*10: EQ Freq
*2: Delay Time 1	*11: LPF
*3: Delay Time 2	*12: Manual
*4: Delay Time 3	*13: Azimuth
*5: Delay Time 4	*14: Accl
*6: Rate 1	*15: Bass Cut Freq
*7: Rate 2	*16: Reverb Time
*8: HF Damp	*17: Distance
*9: Cutoff Freq	*18: Boost Freq

• MSB/LSB

The MSB/LSB column shows the following ** portion of the System Exclusive message. (Hexadecimal notation)

For Effect Type (Data section)

F0 41 10 00 11 12 00 40 0n 00 ** sum F7

For Effect Parameter (LSB part of address)

F0 41 10 00 11 12 00 40 0n ** data sum F7

(n: 1 to 6, sum: checksum)

■ The Full Effect Mode

Parameter	Setting Value	Value(Hex.)	MSB/LSB(H)
01 : High Quality Reverb			00 11
Type	Room1/2/Plate1/2/Hall1/2	00 - 05	03
Pre Dly	0ms - 80ms - 635ms	*5	04
Reverb Time	0.1s - 2s - 38s	*16	05
HF Damp	-10 - -4 - 0	00 - 0A	06
ER Pre Dly	0 - 40ms - 635 ms	*5	07
ER Mix	0 - 15 - 127	00 - 7F	08
Diffusion	0 - 9 - 10	00 - 0A	09
Tone Low	-12dB - 0dB - +12dB	34 - 4C	0A
Tone High	-12dB - 0dB - +12dB	34 - 4C	0B
Balance	D > 0E - D0 < E	00 - 7F	0C
EQ Low Freq	200/400Hz	00 - 01	0D
EQ Low Gain	-12dB - 0dB - +12dB	34 - 4C	0E
EQ Mid1 Freq	200Hz - 315Hz - 6300 Hz	*10	0F
EQ Mid1 Q	0.5/1.0/2.0/4.0/9.0	00 - 04	10
EQ Mid1 Gain	-12dB - 0dB - +12dB	34 - 4C	11
EQ Mid2 Freq	200Hz - 800Hz - 6300 Hz	*10	12
EQ Mid2 Q	0.5/1.0/2.0/4.0/9.0	00 - 04	13
EQ Mid2 Gain	-12dB - 0dB - +12dB	34 - 4C	14
EQ High Freq	4k/8kHz	00 - 01	15
EQ High Gain	-12dB - 0dB - +12dB	34 - 4C	16

02 : Mic Simulator

00 12

Mic Conv	Off/On	00 - 01	03
Input	DR-20/Sml.Dy./Hed.Dy./Flat	00 - 03	04
Output	Sml.Dy./Voc.Dy./Lrg.Dy./Sml.Ca./Lrg.Cn./Vit.C/Flat	00 - 06	05
Phase	-/+	00 - 01	06
Bass Cut Switch	Off/On	00 - 01	07
Bass Cut Freq	20Hz - 2000Hz	*15	08
Distance Switch	Off/On	00 - 01	09
Prox. Fx	-12dB - 0dB - +12dB	34 - 4C	0A
Distance	0 - 127	0 - 7F	0B
Limiter Switch	Off/On	00 - 01	0C
Lm Freq	20Hz - 115Hz - 2000Hz	*15	0D
Lm Gain	-60dB - +2dB - +24db	04 - 58	0E
Lm Threshold	-60dB - 0dB	04 - 40	0F
Lm Attack	0 - 20 - 127	00 - 7F	10
Lm Release	0 - 30 - 127	00 - 7F	11

Parameter	Setting Value	Value(Hex.)	MSB/LSB(H)
03 : Vocoder			00 13
Speech Input	Mic1/2/Wave1/2	00 - 03	03
Mode Select	1 - 3 - 6	00 - 05	04
Speech Gain	0 - 100 - 127	00 - 7F	05
Speech Cutoff	250Hz - 630Hz - 800Hz	*9	06
Speech Mix Level	0 - 25 - 127	00 - 7F	07
Response Time	Slow/Normal/Fast	00 - 02	08
Level	0 - 127	00 - 7F	09

04 : Vocal Multi

00 14

Ns Threshold	0 - 127	00 - 7F	03
Lm Threshold	0 - 127	00 - 7F	04
De-esser Level	0 - 8 - 127	00 - 7F	05
Enhancer Level	-64 - +5 - +63	00 - 7F	06
EQ Low Gain	-12dB - +1dB - +12dB	34 - 4C	07
EQ Mid Freq	200Hz - 800Hz - 6.3kHz	*10	08
EQ Mid Q	0.5/1.0/2.0/4.0/9.0	00 - 04	09
EQ Mid Gain	-12dB - +2dB - +12dB	34 - 4C	0A
EQ High Gain	-12dB - +4dB - +12dB	34 - 4C	0B
Ps P.Coarse	-24 - 0 - +12	28 - 4C	0C
Ps P.Fine	-100 - -48 - +100	0B - 72	0D
Ps Balance	D > 0E - D > 42E - D0 < E	00 - 7F	0E
Dly Time	0ms - 260ms - 500ms	*4	0F
Dly Feedback	-98% - -10% - +98%	0F - 71	10
Dly Balance	D > 0E - D > 22E - D0 < E	00 - 7F	11
Cho Rate	0.05 - 0.65 - 10.0	*6	12
Cho Depth	0 - 30 - 127	00 - 7F	13
Cho Balance	D > 0 E - D=E - D0 < E	00 - 7F	14

05 : Game

00 16

Enhancer Level	-64 - +35 - +63	00 - 7F	03
Low Boost Level	0dB - +8dB - 18dB	40 - 56	04
Low Boost Freq	60Hz - 400Hz	*17	05
Lm Mix Level	0 - 127	00 - 7F	06
GtRv Mix Level	0 - 70 - 127	00 - 7F	07
Rv Mix Level	0 - 60 - 127	00 - 7F	08
3D Switch	Off/On	00 - 1	09
3D Range	1 - 3 - 4	00 - 3	0A
Out	Speaker/Phones	00 - 1	0B
Lm Threshold	0 - 112 - 127	00 - 7F	0C
GtRv Pre Dly	0ms - 20ms - 100ms	00 - 7F	0D
GtRv Time	5ms - 15ms - 500ms	01 - 63	0E
Rv Type	Room1/2/Stage1/2/Hall1/2	00 - 05	0F
Rv Pre Delay	0ms - 200ms - 500ms	*4	10
Rv Time	0 - 26 - 127	00 - 7F	11
Rv HF Damp	315Hz - 6.3kHz - 8kHz	*8	12
Rv Low Gain	-12dB - +2dB - +12dB	34 - 4C	13
Rv High Gain	-12dB - +4dB - +12dB	34 - 4C	14
Low Gain	-12dB - +2dB - +12dB	34 - 4C	15
High Gain	-12dB - +4dB - +12dB	34 - 4C	16
Level	0 - 100 - 127	00 - 7F	17

06 : Rotary Multi

(Parameters are equivalent with those for the 47 : **Rotary Multi** insertion effect in the Compact Effect mode.)

07 : GTR Multi 1

(Parameters are equivalent with those for the 48 : **GTR Multi 1** insertion effect in the Compact Effect mode.)

08 : GTR Multi 2

(Parameters are equivalent with those for the 49 : **GTR Multi 2** insertion effect in the Compact Effect mode.)

09 : GTR Multi 3

(Parameters are equivalent with those for the 50 : **GTR Multi 3** insertion effect in the Compact Effect mode.)

10 : Clean Gt Multi 1

(Parameters are equivalent with those for the 51 : **Clean Gt Multi1** insertion effect in the Compact Effect mode.)

11 : Clean Gt Multi 2

(Parameters are equivalent with those for the 52 : **Clean Gt Multi2** insertion effect in the Compact Effect mode.)

12 : Bass Multi

(Parameters are equivalent with those for the 53 : **Bass Multi** insertion effect in the Compact Effect mode.)

Compact Effect mode.)

13 : E.Piano Multi(Parameters are equivalent with those for the **54 : E.Piano Multi** insertion effect in the Compact Effect mode.)**14 : Keyboard Multi**(Parameters are equivalent with those for the **55 : Keyboard Multi** insertion effect in the Compact Effect mode.)**■ The Compact Effect Mode****● System Effects**

Parameter	Setting Value	Value(Hex.)	MSB/LSB(H)
Delay 00 21/00 31			
Dly Tm LtoL	0.0ms - 110ms - 360ms	*4 (00 - 77)	03
Dly Tm LtoR	0.0ms - 13.0ms - 360ms	*4 (00 - 77)	04
Dly Tm RtoL	0.0ms - 100ms - 360ms	*4 (00 - 77)	05
Dly Tm RtoL	0.0ms - 8.0ms - 360ms	*4 (00 - 77)	06
Feedback Level	-48% - -34% - +48%	28 - 58	07
Cross Fd Level	-48% - +20% - +48%	28 - 58	08
HF Damp	315Hz - 8kHz/Bypass	*8	09
Cross HF Damp	315Hz - 6.3kHz - 8kHz/Bypass	*8	0A
Cross Balance	0 - 98 - 127	00 - 7F	0B
Balance	D > E0 - D0 < E	00 - 7F	0C

Parameter	Setting Value	Value(Hex.)	MSB/LSB(H)
Chorus 00 22			
Type	Mode1 - 2 - 4	00 - 03	03
Pre Filter	Off/LPF/HPF	00 - 02	04
Cutoff	250Hz - 630Hz - 8000Hz	*9	05
Pre Dly	0.0ms - 30.0ms - 100 ms	*1	06
Rate	0.05 - 0.35 - 10.0	*6	07
Depth	0 - 116 - 127	00 - 7F	08
Balance	D > E0 - D0 < E	00 - 7F	09

Parameter	Setting Value	Value(Hex.)	MSB/LSB(H)
Reverb 00 32			
Type	Room1/2/Stage1/2/Hall1/2	00 - 05	03
Pre Dly	0.0ms - 100ms	*1	04
Reverb Time	0 - 23 - 127	00 - 7F	05
HF Damp	315 - 8kHz/Bypass	*8	06
Low Gain	-12dB - +2dB - +12dB	34 - 4C	07
High Gain	-12dB - +6dB - +12dB	34 - 4C	08
Balance	D > E0 - D0 < E	00 - 7F	09

● Insertion Effects**○ Effects that modify the tone (filter type)**

Parameter	Setting Value	Value(Hex.)	MSB/LSB(H)
00 : Noise Suppressor 00 00			
Noise Suppressor	0 - 10 - 127	00 - 7F	25

Parameter	Setting Value	Value(Hex.)	MSB/LSB(H)
01 : Stereo-EQ 01 00			
Low Freq	200/400Hz	00/01	03
Low Gain	-12dB - +6dB - +12dB	34 - 4C	04
Hi Freq	4k/ 8kHz	00/01	05
Hi Gain	-12dB - -3dB - +12dB	34 - 4C	06
M1 Freq	200Hz - 400Hz - 6.3kHz	*10	07
M1 Q	0.5/1.0/2.0/4.0/9.0	00/01/02/03/04	08
M1 Gain	-12dB - -8dB - +12dB	34 - 4C	09
M2 Freq	200Hz - 2.5kHz - 6.3kHz	*10	0A
M2 Q	0.5/1.0/2.0/4.0/9.0	00/01/02/03/04	0B
M2 Gain	-12dB - +6dB - +12dB	34 - 4C	0C
Level	0 - 127	00 - 7F	16
Noise Suppressor	0 - 10 - 127	00 - 7F	25

Parameter	Setting Value	Value(Hex.)	MSB/LSB(H)
02 : Spectrum 01 01			
Band 1	-12dB - +5dB - +12dB	34 - 4C	03
Band 2	-12dB - +2dB - +12dB	34 - 4C	04
Band 3	-12dB - -2dB - +12dB	34 - 4C	05
Band 4	-12dB - -1dB - +12dB	34 - 4C	06
Band 5	-12dB - +3dB - +12dB	34 - 4C	07
Band 6	-12dB - +5dB - +12dB	34 - 4C	08
Band 7	-12dB - +6dB - +12dB	34 - 4C	09
Band 8	-12dB - +6dB - +12dB	34 - 4C	0A
Width	0.5/1.0/2.0/4.0/9.0	00/01/02/03/04	0B
Pan	L63 - 0 - R63	00 - 7F	15
Level	0 - 127	00 - 7F	16
Noise Suppressor	0 - 10 - 127	00 - 7F	25

Parameter	Setting Value	Value(Hex.)	MSB/LSB(H)
03 : Enhancer 01 02			
Sens	0 - 64 - 127	00 - 7F	03
Mix	0 - 127	00 - 7F	04
Low Gain	-12dB - 0dB - +12dB	34 - 4C	13
Hi Gain	-12dB - 0dB - +12dB	34 - 4C	14
Level	0 - 127	00 - 7F	16
Noise Suppressor	0 - 10 - 127	00 - 7F	25

Parameter	Setting Value	Value(Hex.)	MSB/LSB(H)
04 : Humanizer 01 03			
Drive	0 - 90 - 127	00 - 7F	03
Drive Sw	Off/ On	00/01	04
Vowel	a/i/u/e/o	00/01/02/03/04	05
Accel	0 - 10 - 15	*14	06
Low Gain	-12dB - 0dB - +12dB	34 - 4C	13
Hi Gain	-12dB - 0dB - +12dB	34 - 4C	14
Pan	L63 - 0 - R63	00 - 7F	15
Level	0 - 127	00 - 7F	16
Noise Suppressor	0 - 40 - 127	00 - 7F	25

○ Effects that distort the sound (distortion type)

Parameter	Setting Value	Value(Hex.)	MSB/LSB(H)
05 : Overdrive 01 10			
Drive	0 - 90 - 127	00 - 7F	03
Amp Type	Small/Bltn/2-Stk/3-Stk	00/01/02/03	04
Amp Sw	Off/ On	00/01	05
Low Gain	-12dB - 0dB - +12dB	34 - 4C	13
Hi Gain	-12dB - 0dB - +12dB	34 - 4C	14
Pan	L63 - 0 - R63	00 - 7F	15
Level	0 - 80 - 127	00 - 7F	16
Noise Suppressor	0 - 60 - 127	00 - 7F	25

Parameter	Setting Value	Value(Hex.)	MSB/LSB(H)
06 : Distortion 01 11			
Drive	0 - 127	00 - 7F	03
Amp Type	Small/Bltn/2-Stk/3-Stk	00/01/02/03	04
Amp Sw	Off/ On	00/01	05
Low Gain	-12dB - 0dB - +12dB	34 - 4C	13
Hi Gain	-12dB - 0dB - +12dB	34 - 4C	14
Pan	L63 - 0 - R63	00 - 7F	15
Level	0 - 80 - 127	00 - 7F	16
Noise Suppressor	0 - 70 - 127	00 - 7F	25

○ Effects that modulate the sound (modulation type)

Parameter	Setting Value	Value(Hex.)	MSB/LSB(H)
07 : Phaser 01 20			
Manual	100Hz - 860Hz - 8kHz	*12	03
Rate	0.05Hz - 0.40Hz - 10.0Hz	*6	04
Depth	0 - 70 - 127	00 - 7F	05
Reso	0 - 127	00 - 7F	06
Mix	0 - 127	00 - 7F	07
Low Gain	-12dB - 0dB - +12dB	34 - 4C	13
Hi Gain	-12dB - 0dB - +12dB	34 - 4C	14
Level	0 - 90 - 127	00 - 7F	16
Noise Suppressor	0 - 10 - 127	00 - 7F	25

Parameter	Setting Value	Value(Hex.)	MSB/LSB(H)
08 : Auto Wah 01 21			
Fil Type	LPF/BPF	00/01	03
Sens	0 - 40 - 127	00 - 7F	04
Manual	0 - 10 - 127	00 - 7F	05
Peak	0 - 20 - 127	00 - 7F	06
Rate	0.05Hz - 2.00Hz - 10.0Hz	*6	07
Depth	0 - 90 - 127	00 - 7F	08
Polarity	Down/ Up	00/01	09
Low Gain	-12dB - 0dB - +12dB	34 - 4C	13
Hi Gain	-12dB - 0dB - +12dB	34 - 4C	14
Pan	L63 - 0 - R63	00 - 7F	15
Level	0 - 90 - 127	00 - 7F	16
Noise Suppressor	0 - 10 - 127	00 - 7F	25

Parameter	Setting Value	Value(Hex.)	MSB/LSB(H)
09 : Rotary 01 22			
Low Slow	0.05Hz - 0.35Hz - 10.0Hz	*6	03
Low Fast	0.05Hz - 6.40Hz - 10.0Hz	*6	04
Low Accl	0 - 3 - 15	*14	05
Low Level	0 - 127	00 - 7F	06
Hi Slow	0.05Hz - 0.90Hz - 10.0Hz	*6	07
Hi Fast	0.05Hz - 7.50Hz - 10.0Hz	*6	08
Hi Accl	0 - 11 - 15	*14	09
Hi Level	0 - 64 - 127	00 - 7F	0A
Separate	0 - 90 - 127	00 - 7F	0B
Speed	Slow/ Fast	00/7F	0D
Low Gain	-12dB - 0dB - +12dB	34 - 4C	13
Hi Gain	-12dB - 0dB - +12dB	34 - 4C	14
Level	0 - 127	00 - 7F	16
Noise Suppressor	0 - 10 - 127	00 - 7F	25

Effect Parameters Chart

Parameter	Setting Value	Value(Hex.)	MSB/LSB(H)
10 : Stereo Flanger 01 23			
Pre Filter	Off/LPF/HPF	00/01/02	03
Cutoff	250Hz - 315Hz - 8kHz	*9	04
Pre Dly	0.0ms - 1.0ms - 100ms	*1	05
Rate	0.05Hz - 0.20Hz - 10.0Hz	*6	06
Depth	0 - 30 - 127	00 - 7F	07
Feedback	-98% - +80% - +98%	0F - 71	08
Phase	0 - 30 - 180	00 - 5A	09
Balance	D > 0E - D=E - D0 < E	00 - 7F	12
Low Gain	-12dB - 0dB - +12dB	34 - 4C	13
Hi Gain	-12dB - 0dB - +12dB	34 - 4C	14
Level	0 - 100 - 127	00 - 7F	16
Noise Suppressor	0 - 10 - 127	00 - 7F	25

Parameter	Setting Value	Value(Hex.)	MSB/LSB(H)
11 : Step Flanger 01 24			
Pre Dly	0.0ms - 1.0ms - 100ms	*1	03
Rate	0.05Hz - 0.20Hz - 10.0Hz	*6	04
Depth	0 - 30 - 127	00 - 7F	05
Feedback	-98% - +80% - +98%	0F - 71	06
Phase	0 - 30 - 180	00 - 5A	07
Step Rate	0.05Hz - 3.50Hz - 10.0Hz	*6	08
Balance	D > 0E - D=E - D0 < E	00 - 7F	12
Low Gain	-12dB - 0dB - +12dB	34 - 4C	13
Hi Gain	-12dB - 0dB - +12dB	34 - 4C	14
Level	0 - 100 - 127	00 - 7F	16
Noise Suppressor	0 - 10 - 127	00 - 7F	25

Parameter	Setting Value	Value(Hex.)	MSB/LSB(H)
12 : Tremolo 01 25			
Mod Wave	Tri/Sqr/Sin/Saw1/Saw2	00/01/02/03/04	03
Mod Rate	0.05Hz - 6.00Hz - 10.0Hz	*6	04
Mod Depth	0 - 60 - 127	00 - 7F	05
Low Gain	-12dB - 0dB - +12dB	34 - 4C	13
Hi Gain	-12dB - 0dB - +12dB	34 - 4C	14
Level	0 - 127	00 - 7F	16
Noise Suppressor	0 - 10 - 127	00 - 7F	25

Parameter	Setting Value	Value(Hex.)	MSB/LSB(H)
13 : Auto Pan 01 26			
Mod Wave	Tri/Sqr/Sin/Saw1/Saw2	00/01/02/03/04	03
Mod Rate	0.05Hz - 4.00Hz - 10.0Hz	*6	04
Mod Depth	0 - 60 - 127	00 - 7F	05
Low Gain	-12dB - 0dB - +12dB	34 - 4C	13
Hi Gain	-12dB - 0dB - +12dB	34 - 4C	14
Level	0 - 127	00 - 7F	16
Noise Suppressor	0 - 10 - 127	00 - 7F	25

○ Effects that affect the level (compressor type)

Parameter	Setting Value	Value(Hex.)	MSB/LSB(H)
14 : Compressor 01 30			
Attack	0 - 64 - 127	00 - 7F	03
Sustain	0 - 64 - 127	00 - 7F	04
Post Gain	0/+6/+12/+18dB	00/01/02/03	05
Low Gain	-12dB - 0dB - +12dB	34 - 4C	13
Hi Gain	-12dB - 0dB - +12dB	34 - 4C	14
Pan	L63 - 0 - R63	00 - 7F	15
Level	0 - 127	00 - 7F	16
Noise Suppressor	0 - 10 - 127	00 - 7F	25

Parameter	Setting Value	Value(Hex.)	MSB/LSB(H)
15 : Limiter 01 31			
Threshold	0 - 20 - 127	00 - 7F	03
Ratio	1/1.5, 1/2, 1/4, 1/100	00/01/02/03	04
Release	0 - 100 - 127	00 - 7F	05
Post Gain	0/+6/+12/+18dB	00/01/02/03	06
Low Gain	-12dB - 0dB - +12dB	34 - 4C	13
Hi Gain	-12dB - 0dB - +12dB	34 - 4C	14
Pan	L63 - 0 - R63	00 - 7F	15
Level	0 - 127	00 - 7F	16
Noise Suppressor	0 - 20 - 127	00 - 7F	25

○ Effects that broaden the sound (chorus type)

Parameter	Setting Value	Value(Hex.)	MSB/LSB(H)
16 : Hexa Chorus 01 40			
Pre Dly	0.0ms - 2.0ms - 100ms	*1	03
Rate	0.05Hz - 0.50Hz - 10.0Hz	*6	04
Depth	0 - 40 - 127	00 - 7F	05
Pre Dly Dev	0 - 10 - 20	00 - 14	06
Depth Dev	-20 - +40 - +20	2C - 54	07
Pan Dev	0 - 20	00 - 14	08
Balance	D > 0E - D=E - D0 < E	00 - 7F	12
Low Gain	-12dB - 0dB - +12dB	34 - 4C	13
Hi Gain	-12dB - 0dB - +12dB	34 - 4C	14
Level	0 - 127	00 - 7F	16
Noise Suppressor	0 - 10 - 127	00 - 7F	25

Parameter	Setting Value	Value(Hex.)	MSB/LSB(H)
17 : Tremolo Chorus 01 41			
Pre Dly	0.0ms - 2.0ms - 100ms	*1	03
Cho Rate	0.05Hz - 0.50Hz - 10.0Hz	*6	04
Cho Depth	0 - 40 - 127	00 - 7F	05
Trem Phase	0 - 90 - 180	00 - 5A	06
Trem Rate	0.05Hz - 4.00Hz - 10.0Hz	*6	07
Trem Sep	0 - 110 - 127	00 - 7F	08
Balance	D > 0E - D30 < E - D0 < E	00 - 7F	12
Low Gain	-12dB - 0dB - +12dB	34 - 4C	13
Hi Gain	-12dB - 0dB - +12dB	34 - 4C	14
Level	0 - 127	00 - 7F	16
Noise Suppressor	0 - 10 - 127	00 - 7F	25

Parameter	Setting Value	Value(Hex.)	MSB/LSB(H)
18 : Stereo Chorus 01 42			
Pre Filter	Off/LPF/HPF	00/01/02	03
Cutoff	250Hz - 315Hz - 8kHz	*9	04
Pre Dly	0.0ms - 2.0ms - 100ms	*1	05
Rate	0.05Hz - 0.50Hz - 10.0Hz	*6	06
Depth	0 - 80 - 127	00 - 7F	07
Phase	0 - 180	00 - 5A	09
Balance	D > 0E - D=E - D0 < E	00 - 7F	12
Low Gain	-12dB - 0dB - +12dB	34 - 4C	13
Hi Gain	-12dB - 0dB - +12dB	34 - 4C	14
Level	0 - 127	00 - 7F	16
Noise Suppressor	0 - 10 - 127	00 - 7F	25

Parameter	Setting Value	Value(Hex.)	MSB/LSB(H)
19 : Space D 01 43			
Pre Dly	0.0ms - 2.0ms - 100ms	*1	03
Rate	0.05Hz - 0.30Hz - 10.0Hz	*6	04
Depth	0 - 80 - 127	00 - 7F	05
Phase	0 - 180	00 - 5A	06
Balance	D > 0E - D=E - D0 < E	00 - 7F	12
Low Gain	-12dB - 0dB - +12dB	34 - 4C	13
Hi Gain	-12dB - 0dB - +12dB	34 - 4C	14
Level	0 - 127	00 - 7F	16
Noise Suppressor	0 - 10 - 127	00 - 7F	25

Parameter	Setting Value	Value(Hex.)	MSB/LSB(H)
20 : 3D Chorus 01 44			
Pre Dly	0.0ms - 2.0ms - 100ms	*1	03
Cho Rate	0.05Hz - 0.50Hz - 10.0Hz	*6	04
Cho Depth	0 - 80 - 127	00 - 7F	05
Out	Speaker/Phones	00/01	11
Balance	D > 0E - D=E - D0 < E	00 - 7F	12
Low Gain	-12dB - 0dB - +12dB	34 - 4C	13
Hi Gain	-12dB - 0dB - +12dB	34 - 4C	14
Level	0 - 100 - 127	00 - 7F	16
Noise Suppressor	0 - 10 - 127	00 - 7F	25

○ Effects that reverberate the sound (delay/reverb type)

Parameter	Setting Value	Value(Hex.)	MSB/LSB(H)
21 : Stereo Delay 01 50			
Dly Tm L	0.0ms - 250ms - 500ms	*4	03
Dly Tm R	0.0ms - 260ms - 500ms	*4	04
Feedback	-98% - +30% - +98%	0F - 71	05
Fb Mode	Norm/Cross	00/01	06
Phase L	Norm/Invert	00/01	07
Phase R	Norm/Invert	00/01	08
HF Damp	315 - 8kHz/ Bypass	*8	0A
Balance	D > 0E - D60 < E - D0 < E	00 - 7F	12
Low Gain	-12dB - 0dB - +12dB	34 - 4C	13
Hi Gain	-12dB - 0dB - +12dB	34 - 4C	14
Level	0 - 127	00 - 7F	16
Noise Suppressor	0 - 10 - 127	00 - 7F	25

Parameter	Setting Value	Value(Hex.)	MSB/LSB(H)
22 : Mod Delay 01 51			
Dly Tm L	0.0ms - 250ms - 500ms	*4	03
Dly Tm R	0.0ms - 260ms - 500ms	*4	04
Feedback	-98% - +60% - +98%	0F - 71	05
Fb Mode	Norm/Cross	00/01	06
Mod Rate	0.05Hz - 2.00Hz - 10.0Hz	*6	07
Mod Depth	0 - 40 - 127	00 - 7F	08
Mod Phase	0 - 180	00 - 5A	09
HF Damp	315 - 8kHz/ Bypass	*8	0A
Balance	D > 0E - D > 60E - D0 < E	00 - 7F	12
Low Gain	-12dB - 0dB - +12dB	34 - 4C	13
Hi Gain	-12dB - 0dB - +12dB	34 - 4C	14
Level	0 - 127	00 - 7F	16
Noise Suppressor	0 - 10 - 127	00 - 7F	25

Parameter	Setting Value	Value(Hex.)	MSB/LSB(H)
23 : 3 Tap Delay 01 52			
Dly Tm C	200ms - 400ms - 990ms/1s	*2	03
Dly Tm L	200ms - 300ms - 990ms/1s	*2	04
Dly Tm R	200ms - 200ms - 990ms/1s	*2	05
Feedback	-98% - +30% - +98%	0F - 71	06
Dly Lev C	0 - 127	00 - 7F	07
Dly Lev L	0 - 127	00 - 7F	08
Dly Lev R	0 - 127	00 - 7F	09
HF Damp	315 - 8kHz / Bypass	*8	0A
Balance	D > 0E - D > 60E - D0 < E	00 - 7F	12
Low Gain	-12dB - 0dB - +12dB	34 - 4C	13
Hi Gain	-12dB - 0dB - +12dB	34 - 4C	14
Level	0 - 127	00 - 7F	16
Noise Suppressor	0 - 10 - 127	00 - 7F	25

24 : 4 Tap Delay 01 53			
Dly Tm 1	200ms - 250ms - 990ms/1s	*2	03
Dly Tm 2	200ms - 225ms - 990ms/1s	*2	04
Dly Tm 3	200ms - 275ms - 990ms/1s	*2	05
Dly Tm 4	200ms - 300ms - 990ms/1s	*2	06
Dly Lev 1	0 - 127	00 - 7F	07
Dly Lev 2	0 - 127	00 - 7F	08
Dly Lev 3	0 - 127	00 - 7F	09
Dly Lev 4	0 - 127	00 - 7F	0A
Feedback	-98% - +50% - +98%	0F - 71	0B
HF Damp	315 - 8kHz / Bypass	*8	0C
Balance	D > 0E - D > 60E - D0 < E	00 - 7F	12
Low Gain	-12dB - 0dB - +12dB	34 - 4C	13
Hi Gain	-12dB - 0dB - +12dB	34 - 4C	14
Level	0 - 127	00 - 7F	16
Noise Suppressor	0 - 10 - 127	00 - 7F	25

25 : Tm Ctrl Delay 01 54			
Dly Time	200ms - 500ms - 990ms/1s	*3	03
Accel	0 - 7 - 15	*14	04
Feedback	-98% - +30% - +98%	0F - 71	05
HF Damp	315 - 8kHz / Bypass	*8	06
EFX Pan	L63 - 0 - R63	00 - 7F	07
Balance	D > 0E - D > 60E - D0 < E	00 - 7F	12
Low Gain	-12dB - 0dB - +12dB	34 - 4C	13
Hi Gain	-12dB - 0dB - +12dB	34 - 4C	14
Level	0 - 127	00 - 7F	16
Noise Suppressor	0 - 10 - 127	00 - 7F	25

26 : Reverb 01 55			
Type	Room1/2 / Stage1 / 2 / Hall1/2	00/01/02/03/04/05	03
Pre Dly	0.0ms - 30ms - 100ms	*1	04
Time	0 - 120 - 127	00 - 7F	05
HF Damp	315 - 8kHz / Bypass	*8	06
Balance	D > 0E - D=E - D0 < E	00 - 7F	12
Low Gain	-12dB - 0dB - +12dB	34 - 4C	13
Hi Gain	-12dB - 0dB - +12dB	34 - 4C	14
Level	0 - 127	00 - 7F	16
Noise Suppressor	0 - 10 - 127	00 - 7F	25

27 : Gate Reverb 01 56			
Type	Norm / Reverse / Sweep1/2	00/01/02/03	03
Pre Dly	0.0ms - 10ms - 100ms	*1	04
Gate Time	0.0ms - 300ms - 500ms	00 - 63	05
Balance	D > 0E - D=E - D0 < E	00 - 7F	12
Low Gain	-12dB - 0dB - +12dB	34 - 4C	13
Hi Gain	-12dB - 0dB - +12dB	34 - 4C	14
Level	0 - 127	00 - 7F	16
Noise Suppressor	0 - 10 - 127	00 - 7F	25

28 : 3D Delay 01 57			
Dly Tm C	0.0ms - 250ms - 500ms	*4	03
Dly Tm L	0.0ms - 300ms - 500ms	*4	04
Dly Tm R	0.0ms - 320ms - 500ms	*4	05
Feedback	-98% - +30% - +98%	0F - 71	06
Dly Lev C	0 - 110 - 127	00 - 7F	07
Dly Lev L	0 - 127	00 - 7F	08
Dly Lev R	0 - 127	00 - 7F	09
HF Damp	315 - 8kHz / Bypass	*8	0A
Out	Speaker / Phones	00/01	11
Balance	D > 0E - D > 60E - D0 < E	00 - 7F	12
Low Gain	-12dB - 0dB - +12dB	34 - 4C	13
Hi Gain	-12dB - 0dB - +12dB	34 - 4C	14
Level	0 - 127	00 - 7F	16
Noise Suppressor	0 - 10 - 127	00 - 7F	25

○ Effects that modify the pitch (pitch shift type)

Parameter	Setting Value	Value(Hex.)	MSB/LSB(H)
29 : 2 Pitch Shifter 01 60			
Coarse 1	-24 - +7 - +12	28 - 4C	03
Fine 1	-100 - -4 - -100	0E - 72	04
Pre Dly 1	0.0ms - 100ms	*1	05
EFX Pan 1	L63 - 0 - R63	00 - 7F	06
Coarse 2	-24 - -12 - +12	28 - 4C	07
Fine 2	-100 - +4 - +100	0E - 72	08
Pre Dly 2	0.0ms - 100ms	*1	09
EFX Pan 2	L63 - 0 - R63	00 - 7F	0A
Shift Mode	1 - 3 - 5	00 - 04	0B
L.Bal	A > 0B - A=B - A0 < B	00 - 7F	0C
Balance	D > 0E - D=E - D0 < E	00 - 7F	12
Low Gain	-12dB - 0dB - +12dB	34 - 4C	13
Hi Gain	-12dB - 0dB - +12dB	34 - 4C	14
Level	0 - 127	00 - 7F	16
Noise Suppressor	0 - 10 - 127	00 - 7F	25

30 : Fb P.Shifter 01 61			
P.Coarse	-24 - +7 - +12	28 - 4C	03
P.Fine	-100 - -2 - +100	0E - 72	04
Feedback	-98% - +90% - +98%	0F - 71	05
Pre Dly	0.0ms - 100ms	*1	06
Mode	1 - 3 - 5	00 - 04	07
EFX Pan	L63 - 0 - R63	00 - 7F	08
Balance	D > 0E - D=E - D0 < E	00 - 7F	12
Low Gain	-12dB - 0dB - +12dB	34 - 4C	13
Hi Gain	-12dB - 0dB - +12dB	34 - 4C	14
Level	0 - 127	00 - 7F	16
Noise Suppressor	0 - 10 - 127	00 - 7F	25

○ Other Effects

Parameter	Setting Value	Value(Hex.)	MSB/LSB(H)
31 : 3D Auto 01 70			
Azimuth	180/L168 - 0 - R168	*13	03
Speed	0.05Hz - 0.40Hz - 10.0Hz	*6	04
Clockwise	-/+	00/01	05
Turn	Off/On	00/01	06
Out	Speaker / Phones	00/01	11
Level	0 - 127	00 - 7F	16
Noise Suppressor	0 - 10 - 127	00 - 7F	25

32 : 3D Manual 01 71			
Azimuth	180/L168 - 0 - R168	*13	03
Out	Speaker / Phones	00/01	11
Level	0 - 127	00 - 7F	16
Noise Suppressor	0 - 10 - 127	00 - 7F	25

33 : Lo-Fi 1 01 72			
Pre Filter	1 - 2 - 6	00 - 05	03
Lo-Fi Type	1 - 6 - 9	00 - 08	04
Post Filter	1 - 2 - 6	00 - 05	05
Balance	D > 0E - D0 < E	00 - 7F	12
Low Gain	-12dB - 0dB - +12dB	34 - 4C	13
Hi Gain	-12dB - 0dB - +12dB	34 - 4C	14
Pan	L63 - 0 - R63	00 - 7F	15
Level	0 - 127	00 - 7F	16
Noise Suppressor	0 - 10 - 127	00 - 7F	25

34 : Lo-Fi 2 01 73			
Lo-Fi Type	1 - 4 - 6	00 - 05	03
Fil Type	Off/LPF/HPF	00/01/02	04
Cutoff	250Hz - 6.3kHz - 8kHz	*9	05
R.Detune	0 - 10 - 127	00 - 7F	06
R.Nz Lev	0 - 64 - 127	00 - 7F	07
W/P Sel	White/Pink	00/01	08
W/P LPF	250Hz - 315Hz - 6.3kHz/Bypass	*11	09
W/P Level	0 - 64 - 127	00 - 7F	0A
Disc Type	LP/EP/SP/RND	00/01/02/03	0B
Disc LPF	250Hz - 630Hz - 6.3kHz/Bypass	*11	0C
Disc Nz Lev	0 - 50 - 127	00 - 7F	0D
Hum Type	50Hz / 60Hz	00/01	0E
Hum LPF	250Hz - 400Hz - 6.3kHz/Bypass	*11	0F
Hum Level	0 - 15 - 127	00 - 7F	10
M/S	Mono/ Stereo	00 - 01	11
Balance	D > 0E - D0 < E	00 - 7F	12
Low Gain	-12dB - 0dB - +12dB	34 - 4C	13
Hi Gain	-12dB - 0dB - +12dB	34 - 4C	14
Pan(Mono)	L63 - 0 - R63	00 - 7F	15
Level	0 - 127	00 - 7F	16
Noise Suppressor	0 - 10 - 127	00 - 7F	25

Effect Parameters Chart

○ Effects that connect two types of effect in series (series 2)

Parameter	Setting Value	Value(Hex.)	MSB/LSB(H)
35 : OD → Chorus 02 00			
OD Drive	0 - 90 - 127	00 - 7F	03
OD Pan	L63 - 0 - R63	00 - 7F	04
OD Amp	Small/Bltn/2-Stk/3-Stk	00/01/02/03	05
OD Amp Sw	Off/On	00/01	06
Cho Dly	0.0ms - 2.0ms - 100ms	*1	08
Cho Rate	0.05Hz - 0.50Hz - 10.0Hz	*6	09
Cho Depth	0 - 40 - 127	00 - 7F	0A
Cho Bal	D > 0E - D=E - D0 < E	00 - 7F	0C
Low Gain	-12dB - 0dB - +12dB	34 - 4C	13
Hi Gain	-12dB - 0dB - +12dB	34 - 4C	14
Level	0 - 100 - 127	00 - 7F	16
Noise Suppressor	0 - 40 - 127	00 - 7F	25
36 : OD → Flanger 02 01			
OD Drive	0 - 90 - 127	00 - 7F	03
OD Pan	L63 - 0 - R63	00 - 7F	04
OD Amp	Small/Bltn/2-Stk/3-Stk	00/01/02/03	05
OD Amp Sw	Off/On	00/01	06
FL Dly	0.0ms - 1.0ms - 100ms	*1	08
FL Rate	0.05Hz - 0.20Hz - 10.0Hz	*6	09
FL Depth	0 - 30 - 127	00 - 7F	0A
FL Fb	-98% - +80% - +98%	0F - 71	0B
FL Bal	D > 0E - D=E - D0 < E	00 - 7F	0C
Low Gain	-12dB - 0dB - +12dB	34 - 4C	13
Hi Gain	-12dB - 0dB - +12dB	34 - 4C	14
Level	0 - 100 - 127	00 - 7F	16
Noise Suppressor	0 - 40 - 127	00 - 7F	25
37 : OD → Delay 02 02			
OD Drive	0 - 90 - 127	00 - 7F	03
OD Pan	L63 - 0 - R63	00 - 7F	04
OD Amp	Small/Bltn/2-Stk/3-Stk	00/01/02/03	05
OD Amp Sw	Off/On	00/01	06
Dly Time	0.0ms - 250ms - 500ms	*4	08
Dly Fb	-98% - +30% - +98%	0F - 71	09
Dly HF	315Hz - 8kHz/Bypass	*8	0A
Dly Bal	D > 0E - D > 60E - D0 < E	00 - 7F	0C
Low Gain	-12dB - 0dB - +12dB	34 - 4C	13
Hi Gain	-12dB - 0dB - +12dB	34 - 4C	14
Level	0 - 127	00 - 7F	16
Noise Suppressor	0 - 40 - 127	00 - 7F	25
38 : DS → Chorus 02 03			
DS Drive	0 - 127	00 - 7F	03
DS Pan	L63 - 0 - R63	00 - 7F	04
DS Amp	Small/Bltn/2-Stk/3-Stk	00/01/02/03	05
DS Amp Sw	Off/On	00/01	06
Cho Dly	0.0ms - 2.0ms - 100ms	*1	08
Cho Rate	0.05Hz - 0.50Hz - 10.0Hz	*6	09
Cho Depth	0 - 40 - 127	00 - 7F	0A
Cho Bal	D > 0E - D=E - D0 < E	00 - 7F	0C
Low Gain	-12dB - 0dB - +12dB	34 - 4C	13
Hi Gain	-12dB - 0dB - +12dB	34 - 4C	14
Level	0 - 100 - 127	00 - 7F	16
Noise Suppressor	0 - 40 - 127	00 - 7F	25
39 : DS → Flanger 02 04			
DS Drive	0 - 127	00 - 7F	03
DS Pan	L63 - 0 - R63	00 - 7F	04
DS Amp	Small/Bltn/2-Stk/3-Stk	00/01/02/03	05
DS Amp Sw	Off/On	00/01	06
FL Dly	0.0ms - 1.0ms - 100ms	*1	08
FL Rate	0.05Hz - 0.20Hz - 10.0Hz	*6	09
FL Depth	0 - 30 - 127	00 - 7F	0A
FL Fb	-98% - +80% - +98%	0F - 71	0B
FL Bal	D > 0E - D=E - D0 < E	00 - 7F	0C
Low Gain	-12dB - 0dB - +12dB	34 - 4C	13
Hi Gain	-12dB - 0dB - +12dB	34 - 4C	14
Level	0 - 100 - 127	00 - 7F	16
Noise Suppressor	0 - 40 - 127	00 - 7F	25
40 : DS → Delay 02 05			
DS Drive	0 - 127	00 - 7F	03
DS Pan	L63 - 0 - R63	00 - 7F	04
DS Amp	Small/Bltn/2-Stk/3-Stk	00/01/02/03	05
DS Amp Sw	Off/On	00/01	06
Dly Time	0.0ms - 250ms - 500ms	*4	08
Dly Fb	-98% - +30% - +98%	0F - 71	09
Dly HF	315Hz - 8kHz/Bypass	*8	0A
Dly Bal	D > 0E - D > 60E - D0 < E	00 - 7F	0C
Low Gain	-12dB - 0dB - +12dB	34 - 4C	13
Hi Gain	-12dB - 0dB - +12dB	34 - 4C	14
Level	0 - 127	00 - 7F	16
Noise Suppressor	0 - 40 - 127	00 - 7F	25

Parameter	Setting Value	Value(Hex.)	MSB/LSB(H)
41 : EH → Chorus 02 06			
EH Sens	0 - 64 - 127	00 - 7F	03
EH Mix	0 - 64 - 127	00 - 7F	04
Cho Dly	0.0ms - 2.0ms - 100ms	*1	08
Cho Rate	0.05Hz - 0.50Hz - 10.0Hz	*6	09
Cho Depth	0 - 60 - 127	00 - 7F	0A
Cho Bal	D > 0E - D=E - D0 < E	00 - 7F	0C
Low Gain	-12dB - 0dB - +12dB	34 - 4C	13
Hi Gain	-12dB - 0dB - +12dB	34 - 4C	14
Level	0 - 127	00 - 7F	16
Noise Suppressor	0 - 10 - 127	00 - 7F	25
42 : EH → Flanger 02 07			
EH Sens	0 - 64 - 127	00 - 7F	03
EH Mix	0 - 64 - 127	00 - 7F	04
FL Dly	0.0ms - 0.3ms - 100ms	*1	08
FL Rate	0.05Hz - 0.20Hz - 10.0Hz	*6	09
FL Depth	0 - 50 - 127	00 - 7F	0A
FL Fb	-98% - +80% - +98%	0F - 71	0B
FL Bal	D > 0E - D=E - D0 < E	00 - 7F	0C
Low Gain	-12dB - 0dB - +12dB	34 - 4C	13
Hi Gain	-12dB - 0dB - +12dB	34 - 4C	14
Level	0 - 127	00 - 7F	16
Noise Suppressor	0 - 10 - 127	00 - 7F	25
43 : EH → Delay 02 08			
EH Sens	0 - 64 - 127	00 - 7F	03
EH Mix	0 - 64 - 127	00 - 7F	04
Dly Time	0.0ms - 250ms - 500ms	*4	08
Dly Fb	-98% - +30% - +98%	0F - 71	09
Dly HF	315Hz - 8kHz/Bypass	*8	0A
Dly Bal	D > 0E - D > 60E - D0 < E	00 - 7F	0C
Low Gain	-12dB - 0dB - +12dB	34 - 4C	13
Hi Gain	-12dB - 0dB - +12dB	34 - 4C	14
Level	0 - 127	00 - 7F	16
Noise Suppressor	0 - 10 - 127	00 - 7F	25
44 : Cho → Delay 02 09			
Cho Dly	0.0ms - 2.0ms - 100ms	*1	03
Cho Rate	0.05Hz - 0.50Hz - 10.0Hz	*6	04
Cho Depth	0 - 60 - 127	00 - 7F	05
Cho Bal	D > 0E - D=E - D0 < E	00 - 7F	07
Dly Time	0.0ms - 250ms - 500ms	*4	08
Dly Fb	-98% - +30% - +98%	0F - 71	09
Dly HF	315Hz - 8kHz/Bypass	*8	0A
Dly Bal	D > 0E - D > 60E - D0 < E	00 - 7F	0C
Low Gain	-12dB - 0dB - +12dB	34 - 4C	13
Hi Gain	-12dB - 0dB - +12dB	34 - 4C	14
Level	0 - 127	00 - 7F	16
Noise Suppressor	0 - 10 - 127	00 - 7F	25
45 : FL → Delay 02 0A			
FL Dly	0.0ms - 0.3ms - 100ms	*1	03
FL Rate	0.05Hz - 0.20Hz - 10.0Hz	*6	04
FL Depth	0 - 50 - 127	00 - 7F	05
FL Fb	-98% - +80% - +98%	0F - 71	06
FL Bal	D > 0E - D=E - D0 < E	00 - 7F	07
Dly Time	0.0ms - 250ms - 500ms	*4	08
Dly Fb	-98% - +30% - +98%	0F - 71	09
Dly HF	315Hz - 8kHz/Bypass	*8	0A
Dly Bal	D > 0E - D > 60E - D0 < E	00 - 7F	0C
Low Gain	-12dB - 0dB - +12dB	34 - 4C	13
Hi Gain	-12dB - 0dB - +12dB	34 - 4C	14
Level	0 - 127	00 - 7F	16
Noise Suppressor	0 - 10 - 127	00 - 7F	25
46 : Cho → Flanger 02 0B			
Cho Dly	0.0ms - 2.0ms - 100ms	*1	03
Cho Rate	0.05Hz - 0.50Hz - 10.0Hz	*6	04
Cho Depth	0 - 60 - 127	00 - 7F	05
Cho Bal	D > 0E - D=E - D0 < E	00 - 7F	07
FL Dly	0.0ms - 0.3ms - 100ms	*1	08
FL Rate	0.05Hz - 0.20Hz - 10.0Hz	*6	09
FL Depth	0 - 50 - 127	00 - 7F	0A
FL Fb	-98% - +80% - +98%	0F - 71	0B
FL Bal	D > 0E - D=E - D0 < E	00 - 7F	0C
Low Gain	-12dB - 0dB - +12dB	34 - 4C	13
Hi Gain	-12dB - 0dB - +12dB	34 - 4C	14
Level	0 - 127	00 - 7F	16
Noise Suppressor	0 - 10 - 127	00 - 7F	25

○ Effects that connect three or more types of effect in series (series 3/series 4/series 5)

Parameter	Setting Value	Value(Hex.)	MSB/LSB(H)
47 : Rotary Multi 03 00			
OD Drive	0 - 40 - 127	00 - 7F	03
OD Sw	Off/On	00/01	04
EQ L Gain	-12dB - 0dB +12dB	34 - 4C	05
EQ M Fq	200Hz - 1.6kHz - 6.3kHz	*10	06
EQ M Q	0.5/1.0/2.0/4.0/9.0	00/01/02/03/04	07
EQ M Gain	-12dB - 0dB +12dB	34 - 4C	08
EQ H Gain	-12dB - 0dB +12dB	34 - 4C	09
RT L Slow	0.05Hz - 0.35Hz - 10.0Hz	*6	0A
RT L Fast	0.05Hz - 6.40Hz - 10.0Hz	*6	0B
RT Lo Accl	0 - 3 - 15	*14	0C
RT Lo Lev	0 - 127	00 - 7F	0D
RT H Slow	0.05Hz - 0.90Hz - 10.0Hz	*6	0E
RT H Fast	0.05Hz - 7.50Hz - 10.0Hz	*6	0F
RT Hi Accl	0 - 11 - 15	*14	10
RT Hi Lev	0 - 64 - 127	00 - 7F	11
RT Sept	0 - 90 - 127	00 - 7F	12
RT Speed	Slow/Fast	00/7F	13
Level	0 - 127	00 - 7F	16
Noise Suppressor	0 - 30 - 127	00 - 7F	25

48 : GTR Multi 1 04 00			
Cmp Atck	0 - 80 - 127	00 - 7F	03
Cmp Sus	0 - 40 - 127	00 - 7F	04
Cmp Level	0 - 127	00 - 7F	05
Cmp Sw	Off/On	00/01	06
OD Sel	Odrv/Dist	00/01	07
OD Drive	0 - 90 - 127	00 - 7F	08
OD Amp	Small/BltIn/2-Stk/3-Stk	00/01/02/03	09
OD Amp Sw	Off/On	00/01	0A
OD L Gain	-12dB - 0dB +12dB	34 - 4C	0B
OD H Gain	-12dB - 0dB +12dB	34 - 4C	0C
OD Sw	Off/On	00/01	0D
CF Sel	Chorus/Flanger	00/01	0E
CF Rate	0.05Hz - 0.50Hz - 6.40Hz	*7	0F
CF Depth	0 - 40 - 127	00 - 7F	10
CF Fb	-98% - 0% +98%	0F - 71	11
CF Mix	0 - 127	00 - 7F	12
Dly Time	0ms - 250ms - 635ms	*5	13
Dly Fb	0 - 30 - 127	00 - 7F	14
Dly Mix	0 - 60 - 127	00 - 7F	15
Level	0 - 127	00 - 7F	16
Noise Suppressor	0 - 40 - 127	00 - 7F	25

49 : GTR Multi 2 04 01			
Cmp Atck	0 - 80 - 127	00 - 7F	03
Cmp Sus	0 - 40 - 127	00 - 7F	04
Cmp Level	0 - 127	00 - 7F	05
Cmp Sw	Off/On	00/01	06
OD Sel	Odrv/Dist	00/01	07
OD Drive	0 - 127	00 - 7F	08
OD Amp	Small/BltIn/2-Stk/3-Stk	00/01/02/03	09
OD Amp Sw	Off/On	00/01	0A
OD Sw	Off/On	00/01	0B
EQ L Gain	-12dB - 0dB +12dB	34 - 4C	0C
EQ M Fq	200 Hz - 1.6kHz - 6.3kHz	*10	0D
EQ M Q	0.5/1.0/2.0/4.0/9.0	00/01/02/03/04	0E
EQ M Gain	-12dB - 0dB +12dB	34 - 4C	0F
EQ H Gain	-12dB - 0dB +12dB	34 - 4C	10
CF Sel	Chorus/Flanger	00/01	11
CF Rate	0.05Hz - 0.20Hz - 6.40Hz	*7	12
CF Depth	0 - 30 - 127	00 - 7F	13
CF Fb	-98% - +80% - +98%	0F - 71	14
CF Mix	0 - 127	00 - 7F	15
Level	0 - 127	00 - 7F	16
Noise Suppressor	0 - 40 - 127	00 - 7F	25

50 : GTR Multi 3 04 02			
Wah Fil	LPF/BPF	00/01	03
Wah Man	0 - 55 - 127	00 - 7F	04
Wah Peak	0 - 20 - 127	00 - 7F	05
Wah Sw	Off/On	00/01	06
OD Sel	Odrv/Dist	00/01	07
OD Drive	0 - 90 - 127	00 - 7F	08
OD Amp	Small/BltIn/2-Stk/3-Stk	00/01/02/03	09
OD Amp Sw	Off/On	00/01	0A
OD L Gain	-12dB - 0dB +12dB	34 - 4C	0B
OD H Gain	-12dB - 0dB +12dB	34 - 4C	0C
OD Sw	Off/On	00/01	0D
CF Sel	Chorus/Flanger	00/01	0E
CF Rate	0.05Hz - 0.50Hz - 6.40Hz	*7	0F
CF Depth	0 - 40 - 127	00 - 7F	10
CF Fb	-98% - 0% +98%	0F - 71	11
CF Mix	0 - 50 - 127	00 - 7F	12
Dly Time	0ms - 250ms - 635ms	*5	13
Dly Fb	0 - 30 - 127	00 - 7F	14
Dly Mix	0 - 60 - 127	00 - 7F	15
Level	0 - 127	00 - 7F	16
Noise Suppressor	0 - 40 - 127	00 - 7F	25

Parameter	Setting Value	Value(Hex.)	MSB/LSB(H)
51 : Clean Gt Multi 1 04 03			
Cmp Atck	0 - 80 - 127	00 - 7F	03
Cmp Sus	0 - 40 - 127	00 - 7F	04
Cmp Level	0 - 127	00 - 7F	05
Cmp Sw	Off/On	00/01	06
EQ L Gain	-12dB - 0dB +12dB	34 - 4C	07
EQ M Fq	200Hz - 1.6kHz - 6.3kHz	*10	08
EQ M Q	0.5/1.0/2.0/4.0/9.0	00/01/02/03/04	09
EQ M Gain	-12dB - 0dB +12dB	34 - 4C	0A
EQ H Gain	-12dB - 0dB +12dB	34 - 4C	0B
CF Sel	Chorus/Flanger	00/01	0C
CF Rate	0.05Hz - 0.50Hz - 6.40Hz	*7	0D
CF Depth	0 - 40 - 127	00 - 7F	0E
CF Fb	-98% - 0% +98%	0F - 71	0F
CF Mix	0 - 127	00 - 7F	10
Dly Time	0ms - 250ms - 635ms	*5	11
Dly Fb	0 - 30 - 127	00 - 7F	12
Dly HF	315Hz - 8kHz/Bypass	*8	13
Dly Mix	0 - 60 - 127	00 - 7F	14
Level	0 - 127	00 - 7F	16
Noise Suppressor	0 - 10 - 127	00 - 7F	25

52 : Clean Gt Multi2 04 04			
AW Filter	LPF/BPF	00/01	03
AW Man	0 - 35 - 127	00 - 7F	04
AW Peak	0 - 40 - 127	00 - 7F	05
AW Rate	0.05Hz - 2.00Hz - 6.40Hz	*7	06
AW Depth	0 - 127	00 - 7F	07
AW Sw	Off/On	00/01	08
EQ L Gain	-12dB - 0dB +12dB	34 - 4C	09
EQ M Fq	200Hz - 1.6kHz - 6.3kHz	*10	0A
EQ M Q	0.5/1.0/2.0/4.0/9.0	00/01/02/03/04	0B
EQ M Gain	-12dB - 0dB +12dB	34 - 4C	0C
EQ H Gain	-12dB - 0dB +12dB	34 - 4C	0D
CF Sel	Chorus/Flanger	00/01	0E
CF Rate	0.05Hz - 0.20Hz - 6.40Hz	*7	0F
CF Depth	0 - 30 - 127	00 - 7F	10
CF Fb	-98% - +80% - +98%	0F - 71	11
CF Mix	0 - 64 - 127	00 - 7F	12
Dly Time	0ms - 250ms - 635ms	*5	13
Dly Fb	0 - 30 - 127	00 - 7F	14
Dly Mix	0 - 60 - 127	00 - 7F	15
Level	0 - 100 - 127	00 - 7F	16
Noise Suppressor	0 - 10 - 127	00 - 7F	25

53 : Bass Multi 04 05			
Cmp Atck	0 - 80 - 127	00 - 7F	03
Cmp Sus	0 - 40 - 127	00 - 7F	04
Cmp Level	0 - 127	00 - 7F	05
Cmp Sw	Off/On	00/01	06
OD Sel	Odrv/Dist	00/01	07
OD Drive	0 - 30 - 127	00 - 7F	08
OD Amp	Small/BltIn/2-Stk	00/01/02	09
OD Amp Sw	Off/On	00/01	0A
OD Sw	Off/On	00/01	0B
EQ L Gain	-12dB - 0dB +12dB	34 - 4C	0C
EQ M Fq	200Hz - 1.6kHz - 6.3kHz	*10	0D
EQ M Q	0.5/1.0/2.0/4.0/9.0	00/01/02/03/04	0E
EQ M Gain	-12dB - 0dB +12dB	34 - 4C	0F
EQ H Gain	-12dB - 0dB +12dB	34 - 4C	10
CF Sel	Chorus/Flanger	00/01	11
CF Rate	0.05Hz - 0.50Hz - 6.40Hz	*7	12
CF Depth	0 - 40 - 127	00 - 7F	13
CF Fb	-98% - 0% +98%	0F - 71	14
CF Mix	0 - 64 - 127	00 - 7F	15
Level	0 - 127	00 - 7F	16
Noise Suppressor	0 - 40 - 127	00 - 7F	25

54 : E.Piano Multi 04 06			
EH Sens	0 - 64 - 127	00 - 7F	03
EH Mix	0 - 80	*12	04
PH Man	100Hz - 620Hz - 8kHz	00 - 7F	05
PH Rate	0.05Hz - 0.85Hz - 6.40Hz	*7	06
PH Depth	0 - 32 - 127	00 - 7F	07
PH Reso	0 - 16 - 127	00 - 7F	08
PH Mix	0 - 64 - 127	00 - 7F	09
CF Sel	Chorus/Flanger	00/01	0A
CF LPF	250 - 6.3k/Bypass	*11	0B
CF Dly	0 - 1.0ms - 100ms	*1	0C
CF Rate	0.05Hz - 0.50Hz - 6.40Hz	*7	0D
CF Depth	0 - 64 - 127	00 - 7F	0E
CF Fb	-98% - 0% +98%	0F - 71	0F
CF Mix	0 - 127	00 - 7F	10
TP Sel	Trem/Pan	00/01	11
TP Mod WV	Tri/Sqr/Sin/Saw1/Saw2	00/01/02/03/04	12
TP Mod RT	0.05Hz - 3.00Hz - 6.40Hz	*7	13
TP Mod Dep	0 - 64 - 127	00 - 7F	14
TP Sw	Off/On	00/01	15
Level	0 - 127	00 - 7F	16
Noise Suppressor	0 - 10 - 127	00 - 7F	25

Effect Parameters Chart

Parameter	Setting Value	Value(Hex.)	MSB/LSB(H)
55 : Keyboard Multi 05 00			
RM Mod Freq	0 - 40 - 127	00 - 7F	03
RM Bal	D > 0E - D > 20E - D0 < E	00 - 7F	04
EQ L Gain	-12dB - 0dB - +12dB	34 - 4C	05
EQ M Fq	200Hz - 1.6kHz - 6.3kHz	*10	06
EQ M Q	0.5/1.0/2.0/4.0/9.0	00/01/02/03/04	07
EQ M Gain	-12dB - 0dB - +12dB	34 - 4C	08
EQ H Gain	-12dB - 0dB - +12dB	34 - 4C	09
PS Coarse	-24 - +7 - +12	28 - 4C	0A
PS Fine	-100 - 0 - +100	0E - 72	0B
PS Mode	1-5	00 - 04	0C
PS Bal	D > 0E - D > 30E - D0 < E	00 - 7F	0D
PH Man	100Hz - 860Hz - 8kHz	*12	0E
PH Rate	0.05Hz - 0.40Hz - 6.40Hz	*7	0F
PH Depth	0 - 70 - 127	00 - 7F	10
PH Reso	0 - 90 - 127	00 - 7F	11
PH Mix	0 - 90 - 127	00 - 7F	12
Dly Time	0ms - 250ms - 635ms	*5	13
Dly Fb	0 - 30 - 127	00 - 7F	14
Dly Mix	0 - 60 - 127	00 - 7F	15
Level	0 - 127	00 - 7F	16
Noise Suppressor	0 - 10 - 127	00 - 7F	25

○ Effects that connect two types of effect in parallel (parallel 2)

Parameter	Setting Value	Value(Hex.)	MSB/LSB(H)
56 : Cho / Delay 11 00			
Cho Dly	0.0ms - 2.0ms - 100ms	*1	03
Cho Rate	0.05Hz - 0.50Hz - 10.0Hz	*6	04
Cho Depth	0 - 40 - 127	00 - 7F	05
Cho Bal	D > 0E - D=E - D0 < E	00 - 7F	07
Cho Pan	L63 - 0 - R63	00 - 7F	12
Cho Level	0 - 127	00 - 7F	13
Dly Time	0.0ms - 250ms - 500ms	*4	08
Dly Fb	-98% - +30% - +98%	0F - 71	09
Dly HF	315Hz - 8kHz/Bypass	*8	0A
Dly Bal	D > 0E - D > 60E - D0 < E	00 - 7F	0C
Dly Pan	L63 - 0 - R63	00 - 7F	14
Dly Level	0 - 127	00 - 7F	15
Level	0 - 127	00 - 7F	16
Noise Suppressor	0 - 10 - 127	00 - 7F	25

Parameter	Setting Value	Value(Hex.)	MSB/LSB(H)
57 : FL / Delay 11 01			
FL Dly	0.0ms - 1.0ms - 100ms	*1	03
FL Rate	0.05Hz - 0.20Hz - 10.0Hz	*6	04
FL Depth	0 - 30 - 127	00 - 7F	05
FL Fb	-98% - +80% - +98%	0F - 71	06
FL Bal	D > 0E - D=E - D0 < E	00 - 7F	07
FL Pan	L63 - 0 - R63	00 - 7F	12
FL Level	0 - 127	00 - 7F	13
Dly Time	0.0ms - 250ms - 500ms	*4	08
Dly Fb	-98% - +30% - +98%	0F - 71	09
Dly HF	315Hz - 8kHz/Bypass	*8	0A
Dly Bal	D > 0E - D > 60E - D0 < E	00 - 7F	0C
Dly Pan	L63 - 0 - R63	00 - 7F	14
Dly Level	0 - 127	00 - 7F	15
Level	0 - 127	00 - 7F	16
Noise Suppressor	0 - 10 - 127	00 - 7F	25

Parameter	Setting Value	Value(Hex.)	MSB/LSB(H)
58 : Cho / Flanger 11 02			
Cho Dly	0.0ms - 2.0ms - 100ms	*1	03
Cho Rate	0.05Hz - 0.50Hz - 10.0Hz	*6	04
Cho Depth	0 - 40 - 127	00 - 7F	05
Cho Bal	D > 0E - D=E - D0 < E	00 - 7F	07
Cho Pan	L63 - 0 - R63	00 - 7F	12
Cho Level	0 - 127	00 - 7F	13
FL Dly	0.0ms - 1.0ms - 100ms	*1	08
FL Rate	0.05Hz - 0.20Hz - 10.0Hz	*6	09
FL Depth	0 - 30 - 127	00 - 7F	0A
FL Fb	-98% - +80% - +98%	0F - 71	0B
FL Bal	D > 0E - D=E - D0 < E	00 - 7F	0C
FL Pan	L63 - 0 - R63	00 - 7F	14
FL Level	0 - 127	00 - 7F	15
Level	0 - 127	00 - 7F	16
Noise Suppressor	0 - 10 - 127	00 - 7F	25

Parameter	Setting Value	Value(Hex.)	MSB/LSB(H)
59 : OD1 / OD2 11 03			
OD1 Sel	Odrv/Dist	00/01	03
OD1 Drive	0 - 90 - 127	00 - 7F	04
OD1 Amp	Small/Bltn/2-Stk/3-Stk	00/01/02/03	05
OD1 Amp Sw	Off/On	00/01	06
OD1 Pan	L63 - 0 - R63	00 - 7F	12
OD1 Level	0 - 127	00 - 7F	13
OD2 Sel	Odrv/Dist	00/01	08
OD2 Drive	0 - 127	00 - 7F	09
OD2 Amp	Small/Bltn/2-Stk/3-Stk	00/01/02/03	0A
OD2 Amp Sw	Off/On	00/01	0B
OD2 Pan	L63 - 0 - R63	00 - 7F	14
OD2 Level	0 - 127	00 - 7F	15
Level	0 - 127	00 - 7F	16
Noise Suppressor	0 - 40 - 127	00 - 7F	25

Parameter	Setting Value	Value(Hex.)	MSB/LSB(H)
60 : OD / Rotary 11 04			
OD Sel	Odrv/Dist	00/01	03
OD Drive	0 - 90 - 127	00 - 7F	04
OD Amp	Small/Bltn/2-Stk/3-Stk	00/01/02/03	05
OD Amp Sw	Off/On	00/01	06
OD Pan	L63 - 0 - R63	00 - 7F	12
OD Level	0 - 127	00 - 7F	13
RT L Slow	0.05Hz - 0.35Hz - 10.0Hz	*6	08
RT L Fast	0.05Hz - 6.40Hz - 10.0Hz	*6	09
RT Lo Accl	0 - 3 - 15	*14	0A
RT Lo Lev	0 - 127	00 - 7F	0B
RT H Slow	0.05Hz - 0.90Hz - 10.0Hz	*6	0C
RT H Fast	0.05Hz - 7.50Hz - 10.0Hz	*6	0D
RT Hi Accl	0 - 11 - 15	*14	0E
RT Hi Lev	0 - 64 - 127	00 - 7F	0F
RT Sept	0 - 90 - 127	00 - 7F	10
RT Speed	Slow/Fast	00/7F	11
RT Pan	L63 - 0 - R63	00 - 7F	14
RT Level	0 - 127	00 - 7F	15
Level	0 - 127	00 - 7F	16
Noise Suppressor	0 - 40 - 127	00 - 7F	25

Parameter	Setting Value	Value(Hex.)	MSB/LSB(H)
61 : OD / Phaser 11 05			
OD Sel	Odrv/Dist	00/01	03
OD Drive	0 - 90 - 127	00 - 7F	04
OD Amp	Small/Bltn/2-Stk/3-Stk	00/01/02/03	05
OD Amp Sw	Off/On	00/01	06
OD Pan	L63 - 0 - R63	00 - 7F	12
OD Level	0 - 127	00 - 7F	13
PH Man	100Hz - 860Hz - 8kHz	*12	08
PH Rate	0.05Hz - 0.40Hz - 10.0Hz	*6	09
PH Depth	0 - 70 - 127	00 - 7F	0A
PH Reso	0 - 127	00 - 7F	0B
PH Mix	0 - 127	00 - 7F	0C
PH Pan	L63 - 0 - R63	00 - 7F	14
PH Level	0 - 90 - 127	00 - 7F	15
Level	0 - 127	00 - 7F	16
Noise Suppressor	0 - 40 - 127	00 - 7F	25

Parameter	Setting Value	Value(Hex.)	MSB/LSB(H)
62 : OD / AutoWah 11 06			
OD Sel	Odrv/Dist	00/01	03
OD Drive	0 - 90 - 127	00 - 7F	04
OD Amp	Small/Bltn/2-Stk/3-Stk	00/01/02/03	05
OD Amp Sw	Off/On	00/01	06
OD Pan	L63 - 0 - R63	00 - 7F	12
OD Level	0 - 127	00 - 7F	13
AW Filter	LPF/BPF	00/01	08
AW Sens	0 - 40 - 127	00 - 7F	09
AW Man	0 - 10 - 127	00 - 7F	0A
AW Peak	0 - 20 - 127	00 - 7F	0B
AW Rate	0.05Hz - 2.00Hz - 10.0Hz	*6	0C
AW Depth	0 - 90 - 127	00 - 7F	0D
AW Pol	Down/Up	00/01	0E
AW Pan	L63 - 0 - R63	00 - 7F	14
AW Level	0 - 127	00 - 7F	15
Level	0 - 127	00 - 7F	16
Noise Suppressor	0 - 40 - 127	00 - 7F	25

Parameter	Setting Value	Value(Hex.)	MSB/LSB(H)
63 : PH / Rotary 11 07			
PH Man	100Hz - 860Hz - 8kHz	*12	03
PH Rate	0.05Hz - 0.40Hz - 10.0Hz	*6	04
PH Depth	0 - 70 - 127	00 - 7F	05
PH Reso	0 - 127	00 - 7F	06
PH Mix	0 - 127	00 - 7F	07
PH Pan	L63 - 0 - R63	00 - 7F	12
PH Level	0 - 90 - 127	00 - 7F	13
RT L Slow	0.05Hz - 0.35Hz - 10.0Hz	*6	08
RT L Fast	0.05Hz - 6.40Hz - 10.0Hz	*6	09
RT Lo Accl	0 - 3 - 15	*14	0A
RT Lo Lev	0 - 127	00 - 7F	0B
RT H Slow	0.05Hz - 0.90Hz - 10.0Hz	*6	0C
RT H Fast	0.05Hz - 7.50Hz - 10.0Hz	*6	0D
RT Hi Accl	0 - 11 - 15	*14	0E
RT Hi Lev	0 - 64 - 127	00 - 7F	0F
RT Sept	0 - 90 - 127	00 - 7F	10
RT Speed	Slow/Fast	00/7F	11
RT Pan	L63 - 0 - R63	00 - 7F	14
RT Level	0 - 127	00 - 7F	15
Level	0 - 127	00 - 7F	16
Noise Suppressor	0 - 10 - 127	00 - 7F	25

Parameter	Setting Value	Value(Hex.)	MSB/LSB(H)
64 : PH / AutoWah			11 08
PH Man	100Hz - 860Hz - 8kHz	*12	03
PH Rate	0.05Hz - 0.40Hz - 10.0Hz	*6	04
PH Depth	0 - 70 - 127	00 - 7F	05
PH Reso	0 - 127	00 - 7F	06
PH Mix	0 - 127	00 - 7F	07
PH Pan	L63 - 0 - R63	00 - 7F	12
PH Level	0 - 90 - 127	00 - 7F	13
AW Filter	LPF/ BPF	00/01	08
AW Sens	0 - 40 - 127	00 - 7F	09
AW Man	0 - 10 - 127	00 - 7F	0A
AW Peak	0 - 20 - 127	00 - 7F	0B
AW Rate	0.05Hz - 2.00Hz - 10.0Hz	*6	0C
AW Depth	0 - 90 - 127	00 - 7F	0D
AW Pol	Down/ Up	00/01	0E
AW Pan	L63 - 0 - R63	00 - 7F	14
AW Level	0 - 127	00 - 7F	15
Level	0 - 127	00 - 7F	16
Noise Suppressor	0 - 10 - 127	00 - 7F	25

■ The VT Effect Mode

Parameter	Setting Value	Value(Hex.)	MSB/LSB(H)
VT Effect			00 01
Direct Level	0 - 127	00 - 7F	03
Vocal1 Level	0 - 127	00 - 7F	04
Vocal1 Pitch Mode	Manual /MIDI	00 - 01	05
Vocal1 Pitch	0 - 64 - 127	00 - 7F	06
Vocal1 Formant	0 - 64 - 127	00 - 7F	0A
Vocal1 Pan	L63 - 0 - R63	00 - 7F	0B
Vocal2 Level	0 - 127	00 - 7F	0C
Vocal2 Pitch Mode	Manual /MIDI	00 - 01	0D
Vocal2 Pitch	0 - 64 - 127	00 - 7F	0E
Vocal2 Formant	0 - 64 - 127	00 - 7F	12
Vocal2 Pan	L63 - 0 - R63	00 - 7F	13
Cho Level	0 - 127	00 - 7F	14
Cho Pre Dly	0ms - 1.0ms - 100ms	*1	15
Cho Rate	0.05Hz - 0.45Hz - 10Hz	*6	16
Cho Depth	0 - 111 - 127	00 - 7F	17
Dly Level	0 - 127	00 - 7F	18
Dly Time	0ms - 150ms - 500ms	*3	19
Dly Feedback	-98% - +32% - +98%	0F - 71	1A
Dly HF Damp	315Hz - 8kHz/ Bypass	*8	1B
Rev Level	0 - 127	00 - 7F	1C
Rev Type	Plate/Room/ Hall	00 - 02	1D
Rev Pre Dly	0ms - 74ms - 100ms	*1	1E
Rev Time	0 - 10 - 20	00 - 13	1F

Effect Parameter Conversion Table

Effect Parameter Conversion Table (1/2)

This is a conversion table for each parameter's value and the actual value of the setting.

Value		1	2	3	4	5	6	7	8	9
(Hex)	(Dec)	Pre Delay Time (ms)	Delay Time 1 (ms)	Delay Time 2 (ms)	Delay Time 3 (ms)	Delay Time 4 (ms)	Rate1 (Hz)	Rate2 (Hz)	HF Damp (Hz)	Cutoff Freq (Hz)
00	00	0.0	200	200	0.0	0	0.05	0.05	315	250
01	01	0.1	205	205	0.1	5	0.10	0.10	"	"
02	02	0.2	210	210	0.2	10	0.15	0.15	"	"
03	03	0.3	215	215	0.3	15	0.20	0.20	"	"
04	04	0.4	220	220	0.4	20	0.25	0.25	"	"
05	05	0.5	225	225	0.5	25	0.30	0.30	"	"
06	06	0.6	230	230	0.6	30	0.35	0.35	"	"
07	07	0.7	235	235	0.7	35	0.40	0.40	"	"
08	08	0.8	240	240	0.8	40	0.45	0.45	400	315
09	09	0.9	245	245	0.9	45	0.50	0.50	"	"
0A	10	1.0	250	250	1.0	50	0.55	0.55	"	"
0B	11	1.1	255	255	1.1	55	0.60	0.60	"	"
0C	12	1.2	260	260	1.2	60	0.65	0.65	"	"
0D	13	1.3	265	265	1.3	65	0.70	0.70	"	"
0E	14	1.4	270	270	1.4	70	0.75	0.75	"	"
0F	15	1.5	275	275	1.5	75	0.80	0.80	"	"
10	16	1.6	280	280	1.6	80	0.85	0.85	500	400
11	17	1.7	285	285	1.7	85	0.90	0.90	"	"
12	18	1.8	290	290	1.8	90	0.95	0.95	"	"
13	19	1.9	295	295	1.9	95	1.00	1.00	"	"
14	20	2.0	300	300	2.0	100	1.05	1.05	"	"
15	21	2.1	305	305	2.1	105	1.10	1.10	"	"
16	22	2.2	310	310	2.2	110	1.15	1.15	"	"
17	23	2.3	315	315	2.3	115	1.20	1.20	"	"
18	24	2.4	320	320	2.4	120	1.25	1.25	630	500
19	25	2.5	325	325	2.5	125	1.30	1.30	"	"
1A	26	2.6	330	330	2.6	130	1.35	1.35	"	"
1B	27	2.7	335	335	2.7	135	1.40	1.40	"	"
1C	28	2.8	340	340	2.8	140	1.45	1.45	"	"
1D	29	2.9	345	345	2.9	145	1.50	1.50	"	"
1E	30	3.0	350	350	3.0	150	1.55	1.55	"	"
1F	31	3.1	355	355	3.1	155	1.60	1.60	"	"
20	32	3.2	360	360	3.2	160	1.65	1.65	800	630
21	33	3.3	365	365	3.3	165	1.70	1.70	"	"
22	34	3.4	370	370	3.4	170	1.75	1.75	"	"
23	35	3.5	375	375	3.5	175	1.80	1.80	"	"
24	36	3.6	380	380	3.6	180	1.85	1.85	"	"
25	37	3.7	385	385	3.7	185	1.90	1.90	"	"
26	38	3.8	390	390	3.8	190	1.95	1.95	"	"
27	39	3.9	395	395	3.9	195	2.00	2.00	"	"
28	40	4	400	400	4	200	2.05	2.05	1000	800
29	41	4.1	405	405	4.1	205	2.10	2.10	"	"
2A	42	4.2	410	410	4.2	210	2.15	2.15	"	"
2B	43	4.3	415	415	4.3	215	2.20	2.20	"	"
2C	44	4.4	420	420	4.4	220	2.25	2.25	"	"
2D	45	4.5	425	425	4.5	225	2.30	2.30	"	"
2E	46	4.6	430	430	4.6	230	2.35	2.35	"	"
2F	47	4.7	435	435	4.7	235	2.40	2.40	"	"
30	48	4.8	440	440	4.8	240	2.45	2.45	1250	1000
31	49	4.9	445	445	4.9	245	2.50	2.50	"	"
32	50	5.0	450	450	5.0	250	2.55	2.55	"	"
33	51	5.5	455	455	5.5	255	2.60	2.60	"	"
34	52	6.0	460	460	6.0	260	2.65	2.65	"	"
35	53	6.5	465	465	6.5	265	2.70	2.70	"	"
36	54	7.0	470	470	7.0	270	2.75	2.75	"	"
37	55	7.5	475	475	7.5	275	2.80	2.80	"	"
38	56	8.0	480	480	8.0	280	2.85	2.85	1600	1250
39	57	8.5	485	485	8.5	285	2.90	2.90	"	"
3A	58	9.0	490	490	9.0	290	2.95	2.95	"	"
3B	59	9.5	495	495	9.5	295	3.00	3.00	"	"
3C	60	10	500	500	10	300	3.05	3.05	"	"
3D	61	11	505	505	11	305	3.10	3.10	"	"
3E	62	12	510	510	12	310	3.15	3.15	"	"
3F	63	13	515	515	13	315	3.20	3.20	"	"

Value		1	2	3	4	5	6	7	8	9
(Hex)	(Dec)	Pre Delay Time (ms)	Delay Time 1 (ms)	Delay Time 2 (ms)	Delay Time 3 (ms)	Delay Time 4 (ms)	Rate1 (Hz)	Rate2 (Hz)	HF Damp (Hz)	Cutoff Freq (Hz)
40	64	14	520	520	14	320	3.25	3.25	2000	1600
41	65	15	525	525	15	325	3.30	3.30	"	"
42	66	16	530	530	16	330	3.35	3.35	"	"
43	67	17	535	535	17	335	3.40	3.40	"	"
44	68	18	540	540	18	340	3.45	3.45	"	"
45	69	19	545	545	19	345	3.50	3.50	"	"
46	70	20	550	550	20	350	3.55	3.55	"	"
47	71	21	560	555	21	355	3.60	3.60	"	"
48	72	22	570	560	22	360	3.65	3.65	2500	2000
49	73	23	580	565	23	365	3.70	3.70	"	"
4A	74	24	590	570	24	370	3.75	3.75	"	"
4B	75	25	600	575	25	375	3.80	3.80	"	"
4C	76	26	610	580	26	380	3.85	3.85	"	"
4D	77	27	620	585	27	385	3.90	3.90	"	"
4E	78	28	630	590	28	390	3.95	3.95	"	"
4F	79	29	640	595	29	395	4.00	4.00	"	"
50	80	30	650	600	30	400	4.05	4.05	3150	2500
51	81	31	660	610	31	405	4.10	4.10	"	"
52	82	32	670	620	32	410	4.15	4.15	"	"
53	83	33	680	630	33	415	4.20	4.20	"	"
54	84	34	690	640	34	420	4.25	4.25	"	"
55	85	35	700	650	35	425	4.30	4.30	"	"
56	86	36	710	660	36	430	4.35	4.35	"	"
57	87	37	720	670	37	435	4.40	4.40	"	"
58	88	38	730	680	38	440	4.45	4.45	4000	3150
59	89	39	740	690	39	445	4.50	4.50	"	"
5A	90	40	750	700	40	450	4.55	4.55	"	"
5B	91	41	760	710	50	455	4.60	4.60	"	"
5C	92	42	770	720	60	460	4.65	4.65	"	"
5D	93	43	780	730	70	465	4.70	4.70	"	"
5E	94	44	790	740	80	470	4.75	4.75	"	"
5F	95	45	800	750	90	475	4.80	4.80	"	"
60	96	46	810	760	100	480	4.85	4.85	5000	4000
61	97	47	820	770	110	485	4.90	4.90	"	"
62	98	48	830	780	120	490	4.95	4.95	"	"
63	99	49	840	790	130	495	5.00	5.00	"	"
64	100	50	850	800	140	500	5.10	5.05	"	"
65	101	52	860	810	150	505	5.20	5.10	"	"
66	102	54	870	820	160	510	5.30	5.15	"	"
67	103	56	880	830	170	515	5.40	5.20	"	"
68	104	58	890	840	180	520	5.50	5.25	6300	5000
69	105	60	900	850	190	525	5.60	5.30	"	"
6A	106	62	910	860	200	530	5.70	5.35	"	"
6B	107	64	920	870	210	535	5.80	5.40	"	"
6C	108	66	930	880	220	540	5.90	5.45	"	"
6D	109	68	940	890	230	545	6.00	5.50	"	"
6E	110	70	950	900	240	550	6.10	5.55	"	"
6F	111	72	960	910	250	555	6.20	5.60	"	"
70	112	74	970	920	260	560	6.30	5.65	8000	6300
71	113	76	980	930	270	565	6.40	5.70	"	"
72	114	78	990	940	280	570	6.50	5.75	"	"
73	115	80	1000	950	290	575	6.60	5.80	"	"
74	116	82	--	960	300	580	6.70	5.85	"	"
75	117	84	--	970	320	585	6.80	5.90	"	"
76	118	86	--	980	340	590	6.90	5.95	"	"
77	119	88	--	990	360	595	7.00	6.00	"	"
78	120	90	--	1000	380	600	7.50	6.05	Bypass	8000
79	121	92	--	1000	400	605	8.00	6.10	"	"
7A	122	94	--	1000	420	610	8.50	6.15	"	"
7B	123	96	--	1000	440	615	9.00	6.20	"	"
7C	124	98	--	1000	460	620	9.50	6.25	"	"
7D	125	100	--	1000	480	625	10.00	6.30	"	"
7E	126	100	--	1000	500	630	10.00	6.35	"	"
7F	127	100	--	1000	500	635	10.00	6.40	"	"

Effect Parameter Conversion Table (2/2)

Value		1 Pre Delay Time	2 Delay Time 1	3 Delay Time 2	4 Delay Time 3	5 Delay Time 4	6 Rate1	7 Rate2	8 HF Damp
00	00	200	250	100	L180 (=R180)	0	20	0.1	60
01	01	"	"	110	"	"	"	0.2	80
02	02	"	"	120	"	"	"	0.3	100
03	03	"	"	130	"	"	"	0.4	120
04	04	"	"	140	"	"	"	0.5	140
05	05	"	"	150	"	"	"	0.6	160
06	06	"	"	160	L168	"	"	0.7	180
07	07	"	"	170	"	"	"	0.8	200
08	08	250	315	180	"	1	25	0.9	300
09	09	"	"	190	"	"	"	1.0	400
0A	10	"	"	200	L156	"	"	1.1	--
0B	11	"	"	210	"	"	"	1.2	--
0C	12	"	"	220	"	"	"	1.3	--
0D	13	"	"	230	"	"	"	1.4	--
0E	14	"	"	240	L144	"	"	1.5	--
0F	15	"	"	250	"	"	"	1.6	--
10	16	315	400	260	"	2	35	1.7	--
11	17	"	"	270	"	"	"	1.8	--
12	18	"	"	280	L132	"	"	1.9	--
13	19	"	"	290	"	"	"	2.0	--
14	20	"	"	300	"	"	"	2.1	--
15	21	"	"	320	"	"	"	2.2	--
16	22	"	"	340	L120	"	"	2.3	--
17	23	"	"	360	"	"	"	2.4	--
18	24	400	500	380	"	3	50	2.5	--
19	25	"	"	400	"	"	"	2.6	--
1A	26	"	"	420	L108	"	"	2.7	--
1B	27	"	"	440	"	"	"	2.8	--
1C	28	"	"	460	"	"	"	2.9	--
1D	29	"	"	480	"	"	"	3.0	--
1E	30	"	"	500	L96	"	"	3.1	--
1F	31	"	"	520	"	"	"	3.2	--
20	32	500	630	540	"	4	85	3.3	--
21	33	"	"	560	"	"	"	3.4	--
22	34	"	"	580	L84	"	"	3.5	--
23	35	"	"	600	"	"	"	3.6	--
24	36	"	"	620	"	"	"	3.7	--
25	37	"	"	640	"	"	"	3.8	--
26	38	"	"	660	L72	"	"	3.9	--
27	39	"	"	680	"	"	"	4.0	--
28	40	630	800	700	"	5	115	4.1	--
29	41	"	"	720	"	"	"	4.2	--
2A	42	"	"	740	L60	"	"	4.3	--
2B	43	"	"	760	"	"	"	4.4	--
2C	44	"	"	780	"	"	"	4.5	--
2D	45	"	"	800	"	"	"	4.6	--
2E	46	"	"	820	L48	"	"	4.7	--
2F	47	"	"	840	"	"	"	4.8	--
30	48	800	1000	860	"	6	150	4.9	--
31	49	"	"	880	"	"	"	5.0	--
32	50	"	"	900	L36	"	"	5.1	--
33	51	"	"	920	"	"	"	5.2	--
34	52	"	"	940	"	"	"	5.3	--
35	53	"	"	960	"	"	"	5.4	--
36	54	"	"	980	L24	"	"	5.5	--
37	55	"	"	1000	"	"	"	5.6	--
38	56	1000	1250	1100	"	7	200	5.7	--
39	57	"	"	1200	"	"	"	5.8	--
3A	58	"	"	1300	L12	"	"	5.9	--
3B	59	"	"	1400	"	"	"	6.0	--
3C	60	"	"	1500	"	"	"	6.1	--
3D	61	"	"	1600	"	"	"	6.2	--
3E	62	"	"	1700	0	"	"	6.3	--
3F	63	"	"	1800	"	"	"	6.4	--

Value		1	2	3	4	5	6	7	8
		Pre Delay Time	Delay Time 1	Delay Time 2	Delay Time 3	Delay Time 4	Rate1	Rate2	HF Damp
40	64	1250	1600	1900	0	8	250	6.5	--
41	65	"	"	2000	"	"	"	6.6	--
42	66	"	"	2100	R12	"	"	6.7	--
43	67	"	"	2200	"	"	"	6.8	--
44	68	"	"	2300	"	"	"	6.9	--
45	69	"	"	2400	"	"	"	7.0	--
46	70	"	"	2500	R24	"	"	7.1	--
47	71	"	"	2600	"	"	"	7.2	--
48	72	1600	2000	2700	"	9	350	7.3	--
49	73	"	"	2800	"	"	"	7.4	--
4A	74	"	"	2900	R36	"	"	7.5	--
4B	75	"	"	3000	"	"	"	7.6	--
4C	76	"	"	3100	"	"	"	7.7	--
4D	77	"	"	3200	"	"	"	7.8	--
4E	78	"	"	3300	R48	"	"	7.9	--
4F	79	"	"	3400	"	"	"	8.0	--
50	80	2000	2500	3500	"	10	500	8.1	--
51	81	"	"	3600	"	"	"	8.2	--
52	82	"	"	3700	R60	"	"	8.3	--
53	83	"	"	3800	"	"	"	8.4	--
54	84	"	"	3900	"	"	"	8.5	--
55	85	"	"	4000	"	"	"	8.6	--
56	86	"	"	4100	R72	"	"	8.7	--
57	87	"	"	4200	"	"	"	8.8	--
58	88	2500	3150	4300	"	11	650	8.9	--
59	89	"	"	4400	"	"	"	9.0	--
5A	90	"	"	4500	R84	"	"	9.1	--
5B	91	"	"	4600	"	"	"	9.2	--
5C	92	"	"	4700	"	"	"	9.3	--
5D	93	"	"	4800	"	"	"	9.4	--
5E	94	"	"	4900	R96	"	"	9.5	--
5F	95	"	"	5000	"	"	"	9.6	--
60	96	3150	4000	5100	"	12	850	9.7	--
61	97	"	"	5200	"	"	"	9.8	--
62	98	"	"	5300	R108	"	"	9.9	--
63	99	"	"	5400	"	"	"	10.0	--
64	100	"	"	5500	"	"	"	11.0	--
65	101	"	"	5600	"	"	"	12.0	--
66	102	"	"	5700	R120	"	"	13.0	--
67	103	"	"	5800	"	"	"	14.0	--
68	104	4000	5000	5900	"	13	1000	15.0	--
69	105	"	"	6000	"	"	"	16.0	--
6A	106	"	"	6100	R132	"	"	17.0	--
6B	107	"	"	6200	"	"	"	18.0	--
6C	108	"	"	6300	"	"	"	19.0	--
6D	109	"	"	6400	"	"	"	20.0	--
6E	110	"	"	6500	R144	"	"	21.0	--
6F	111	"	"	6600	"	"	"	22.0	--
70	112	5000	6300	6700	"	14	1500	23.0	--
71	113	"	"	6800	"	"	"	24.0	--
72	114	"	"	6900	R156	"	"	25.0	--
73	115	"	"	7000	"	"	"	26.0	--
74	116	"	"	7100	"	"	"	27.0	--
75	117	"	"	7200	"	"	"	28.0	--
76	118	"	"	7300	R168	"	"	29.0	--
77	119	"	"	7400	"	"	"	30.0	--
78	120	6300	Bypass	7500	"	15	2000	31.0	--
79	121	"	"	7600	"	"	"	32.0	--
7A	122	"	"	7700	R180 (=L180)	"	"	33.0	--
7B	123	"	"	7800	"	"	"	34.0	--
7C	124	"	"	7900	"	"	"	35.0	--
7D	125	"	"	8000	"	"	"	36.0	--
7E	126	"	"	8000	"	"	"	37.0	--
7F	127	"	"	8000	"	"	"	38.0	--

MIDI Implementation

Model UA-100G Version 1.00 '99.9

1. Receive Data

■ Channel Voice Messages

● Note On

Status	2nd byte	3rd byte
9nH	kkH	vvH

n = MIDI channel number: 0H-FH (ch.1-ch.16)

kk = note number : 00H-7FH (0-127)

* Used for pitch changes when using VT effect

● Pitch Bend Change

Status	2nd byte	3rd byte
EnH	llH	mmH

n = MIDI channel number: 0H-FH (ch.1-ch.16)

mm, ll = Pitch Bend value: 00 00H-40 00H-7F 7FH (-8192-0- +8191)

* Used for pitch changes when using VT effect

● Control Change

You can control the main parameters for the UA-100's mixer using Control Change messages.

* Note that the controller numbers used by the UA-100 differ from the Control Change messages defined in the MIDI standard, and are used to control proprietary parameters for the UA-100.

Status	2nd byte	3rd byte
BnH	mmH	llH

n = MIDI channel number: 0H-FH (ch. 1 to ch. 16:Refer to the correspondence chart)

mm = Mixer parameter number:Refer to the correspondence chart

ll = Mixer parameter value: 00H - 7FH (0 - 127)

Correspondences Between MIDI Channels and Mixer Signals

MIDI channel	Signal
1Ch.	LINE (Line Mode), MIC1/GUITAR (Mic Mode), MIC1+MIC2 (MIC1+MIC2 Mode)
2Ch.	MIC2 (Mic mode only)
3Ch.	WAVE1
4Ch.	WAVE2
5Ch.	SysRET(system effect return Main bus)
6Ch.	SysSUB(system effect return Sub bus)
15Ch.	WAVE (Rec)
16Ch.	LINE (Master)

Mixer parameters and setting ranges

Parameter	mm	ll (setting range)
MIC/LINE Selector	21 (15H)	0: Mic Mode, 1: Line Mode, 2: MIC1+MIC2 Mode
Pan	10 (0AH)	0 (left) - 64 (center) - 127 (right)
Send 1	16 (10H)	0 - 127: Full/Compact Effect mode only
Send 2	17 (11H)	0 - 127: Full/Compact Effect mode only
Mute	18 (12H)	0 (OFF), 1 (ON: Mute)
Solo	19 (13H)	0 (OFF), 1 (ON: Solo)
Sub Fader	20 (14H)	0 - 127
Main Fader	7 (07H)	0 - 127
Selector	22 (16H)	<Full/Compact Effect mode> 0: MIC1 (Mic Mode), LINE (Line Mode), MIC1+MIC2 (MIC1+MIC2 Mode), 1: MIC2 (Mic Mode only), 2: WAVE1, 3: WAVE2, 4 to 7: CH1 to 4, 8: SUB, 9: MAIN <VT Effect mode> 0: MIC1 (Mic Mode), LINE (Line Mode), 1: MIC2 (Mic Mode only), 2: WAVE1, 3: WAVE2, 4: VT_OUT, 5: MAIN
Effect Switch	23 (17H)	0 (OFF), 1 (ON: Apply effect)

Correspondences Between Mixer Signals and Parameters

Parameter	MIC1/LINE/ MIC1MIC2 1Ch.	MIC2 2Ch.	WAVE1 3Ch.	WAVE2 4Ch.	SysRET 5Ch.	SysSUB6 Ch.	WAVE 15Ch.	LINE 16Ch.
MIC/LINE Selector 21 (15H)	0	-	-	-	-	-	-	-
Pan 10 (0AH)	0	0	-	-	-	-	-	-
Send 1 16 (10H)	0	0	0	0	0	0	-	-
Send 2 17 (11H)	0	0	0	0	0	0	-	-
Mute 18 (12H)	0	0	0	0	-	-	-	-
Solo 19 (13H)	0	0	0	0	-	-	-	-
Sub Fader 20 (14H)	0	0	0	0	-	-	-	-
Main Fader 7 (07H)	0	0	0	0	-	-	0	0
Selector 22 (16H)	-	-	-	-	-	-	0	0
Effect Switch23 (17H)	0	0	0	0	0	0	-	-

○ Data Entry (Controller number 6, 38)

Status	2nd byte	3rd byte
BnH	06H	mmH
BnH	26H	llH

n = MIDI channel number: 0H-FH (ch.1-ch.16)

mm, ll = the value of the parameter specified by RPN/NRPN

mm = MSB(upper byte of parameter), ll = LSB(lower byte of parameter)

○ RPN MSB/LSB (Controller number 100, 101)

Status	2nd byte	3rd byte
BnH	65H	mmH
BnH	64H	lH

n = MIDI channel number: 0H-FH (ch.1-ch.16)

mm = upper byte of parameter number specified by RPN (MSB)

l = lower byte of parameter number specified by RPN (LSB)

* The value specified by RPN will not be reset even by messages such as Program Change or Reset All Controller.

RPN

The RPN (Registered Parameter Number) messages are expanded Control Changes, and each function of an RPN is described by the MIDI Standard.

To use these messages, you must first use RPN (Controller number 100 and 110, their order does not matter) to specify the parameter to be controlled, and then use Data Entry messages (Controller number 6, 38) to specify the value of the specified parameter. Once an RPN parameter has been specified, all Data Entry messages received on that channel will modify the value of that parameter. To prevent accidents, it is recommended that you set RPN Null (RPN number = 7FH/7FH) when you have finished setting the value of the desired parameter.

The UA-100 receives the RPNs shown below.

RPN		Data entry		Explanation
00H	00H	mmH	---	Pitch Bend Sensitivity mm: 00H-18H (0-24 semitones), Initial Value = 02H (2 semitones) l: ignored (processed as 00H) specify up to 2 octaves in semitone steps.
00H	01H	mmH	lH	Master Fine Tuning mm, l: 00 00H - 40 00H - 7F 7FH (-100 - 0 - +99.99 cents), Initial Value = 40 00H (0 cent)
00H	02H	mmH	---	Master Coarse Tuning mm: 28H - 40H - 58H (-24 - 0 - +24 semitones), l: ignored (processed as 00H)
7FH	7FH	---	---	RPN null Set condition where RPN and NRPN are unspecified. The data entry messages after set RPN null will be ignored. (No Data entry messages are required after RPN null). Settings already made will not change. mm, l: ignored

■ System Realtime Message

● Active Sensing

Status
FEH

* When Active Sensing is received, the unit will begin monitoring the intervals of all further messages. While monitoring, if the interval between messages exceeds 420 ms, All Sound Off, All Note Off, and Reset All Controllers messages are sent to the Roland UA-100 MIDI 1 and 2 MIDI input device via the USB, and message interval monitoring will be halted.

■ System Exclusive Message

Status	Data byte	Status
F0H	iiH, ddH,, eeH	F7H
F0H:		System Exclusive Message status
ii = ID number:		an ID number (manufacturer ID) to indicate the manufacturer whose Exclusive message this is. Roland's manufacturer ID is 41H. ID numbers 7EH and 7FH are extensions of the MIDI standard: Universal Non-realtime messages (7EH) and Universal Realtime messages (7FH).
dd, ..., ee = data:	00H - 7FH (0 - 127)	
F7H:		EOX (End Of Exclusive)

System Exclusive (SysEx) messages that the UA-100 receives include Universal Non-realtime SysEx messages, Data Request (RQ1) messages, and Data Set (DT1) messages.

● Universal Non-realtime System Exclusive

○ Identity Request

Status	Data byte	Status
F0H	7EH, dev, 06H, 01H	F7H
Byte	Explanation	
F0H:	Exclusive status	
7EH:	ID number (Universal Non-realtime message)	
dev:	Device ID	
06H:	Sub ID#1 (General Information)	
01H:	Sub ID#2 (Identity Request)	
F7H:	EOX (End Of Exclusive)	

* The dev is 10H (own device number) or 7FH (Broadcast)

● Data transmission

With the UA-100, you can use SysEx messages to make a variety of instrument settings.

○ Request data 1 RQ1 (11H)

This message requests the other device to send data. The Address and Size determine the type and amount of data to be sent. There are two types of request: Individual Parameter Request which requests data for an individual parameter, and Bulk Dump Request which requests a large amount of data at once (the UA-100 receives only Individual Parameter Request. For Individual Parameter Request, refer to "Individual Parameter Transmission" (p. 82).

For Individual Parameter Request, the **Data Request 1 (RQ1)** message format is used, and the Address and Size included in the message determine the type and amount of data that is desired.

When a Data Request message is received, if the device is ready to transmit data and if the address and size are appropriate, the requested data will be transmitted as a **Data Set 1 (DT1)** message. If not, nothing will be transmitted.

Status	Data byte	Status
F0H	41H, dev, 00H, 11H, 11H, aaH, bbH, cCH, ddH, ssH, ttH, uuH, vvH, sum	F7H

Byte	Explanation
F0H:	Exclusive status
41H:	ID number (Roland)
10H:	Device ID
00H:	Model ID1 (UA-100)
11H:	Model ID2 (UA-100)
11H:	Command ID (RQ1)
aaH:	Address MSB: upper byte of the starting address of the requested data
bbH:	Address: middle byte of the starting address of the requested data
ccH:	
ddH:	Address LSB: lower byte of the starting address of the requested data
ssH:	Size MSB
ttH:	Size
uuH:	Size
vvH:	Size MSB
sum:	Checksum
F7H:	EOX (End Of Exclusive)

- * The amount of data that can be transmitted at once time will depend on the type of data, and data must be requested using a specific starting address and size. Refer to the Address and Size listed in "Individual Parameter Transmission" (p. 82).

○ Data set 1 DT1 (12H)

This is the message that actually performs data transmission, and is used when you wish to transmit the data.

Status	Data byte	Status
F0H	41H, dev, 00H, 11H, 12H, aaH, bbH, ccH, ddH, eeH, ... ffH, sum	F7H

Byte	Explanation
F0H:	Exclusive status
41H:	ID number (Roland)
10H:	Device ID
00H:	Model ID1 (UA-100)
11H:	Model ID2 (UA-100)
12H:	Command ID (DT1)
aaH:	Address MSB: upper byte of the starting address of the transmitted data
bbH:	Address: middle byte of the starting address of the transmitted data
ccH:	
ddH:	Address LSB: lower byte of the starting address of the transmitted data
eeH:	Data: the actual data to be transmitted. Multiple bytes of data are transmitted starting from the address.
:	:
ffH:	Data
sum:	Checksum
F7H:	EOX (End Of Exclusive)

- * The amount of data that can be transmitted at one time depends on the type of data, and data can be received only from the specified starting address and size. Refer to the Address and Size given in "Individual Parameter Transmission" (p. 82).

- * Data larger than 128 bytes must be divided into packets of 128 bytes or less. If Data Set 1 is transmitted successively, there must be an interval of at least 40 ms between packets.

2. Transmit Data

■ Channel Mode Messages

● All Sounds Off (Controller number 120)

The UA-100 sends in cases like the ones shown below.

- Sent to the MIDI OUT 1/2 ports when a connected USB cable has come loose.
- Sent to the Roland UA-100 MIDI 1/2 MIDI input devices when the interval for receiving Active Sensing messages exceeds 420 ms.

Status	2nd byte	3rd byte
BnH	78H	00H

n = MIDI channel number: 0H-FH (ch.1-ch.16)

- * The external sound module that receives this message turns off all currently-sounding notes on the corresponding channel immediately.

● Reset All Controllers (Controller number 121)

The UA-100 sends in cases like the ones shown below.

- Sent to the MIDI OUT 1/2 ports when a connected USB cable has come loose.
- Sent to the Roland UA-100 MIDI 1/2 MIDI input devices when the interval for receiving Active Sensing messages exceeds 420 ms.

Status	2nd byte	3rd byte
BnH	79H	00H

n = MIDI channel number: 0H-FH (ch.1-ch.16)

- * The external sound module that receives this message will set controllers to their reset values.

Example: In the case of the SC-88Pro, the following Controllers are reset.

Controller	Reset value
Pitch Bend Change	+/-0 (center)
Polyphonic Key Pressure	0 (off)
Channel Pressure	0 (off)
Modulation	0 (off)
Expression	127 (max)
Hold 1	0 (off)
Portamento	0 (off)
Sostenuto	0 (off)
Soft	0 (off)
RPN	unset; previously set data will not change
NRPN	unset; previously set data will not change

● All Notes Off (Controller number 123)

The UA-100 sends in cases like the ones shown below.

- Sent to the MIDI OUT 1/2 ports when a connected USB cable has come loose.
- Sent to the Roland UA-100 MIDI 1/2 MIDI input devices when the interval for receiving Active Sensing messages exceeds 420 ms.

Status	2nd byte	3rd byte
BnH	7BH	00H

n = MIDI channel number: 0H-FH (ch.1-ch.16)

- * The external sound module that receives this message will turn off all notes on the corresponding channel. However if Hold 1 or Sostenuto is ON, the sound will be continued until these are turned off.

■ System Realtime Message

● Active Sensing

Status

FEH

* This will be transmitted constantly at intervals of approximately 250 ms.

■ System Exclusive Messages

● Universal Non-realtime System Exclusive

○ Identity Reply

When an appropriate Identity Request message is received, the internal data will be transmitted.

Status	Data byte	Status
F0H	7EH, 10H, 06H, 02H, 41H, 11H, 01H, 00H, 00H, ssH, ssH, ssH, ssH	F7H

Byte	Explanation
F0H:	Exclusive status
7EH:	ID number (Universal Non-realtime message)
10H:	Device ID
06H:	Sub ID#1 (General Information)
02H:	Sub ID#2 (Identity Reply)
41H:	ID number (Roland)
11H:	Device family code (LSB)
01H:	Device family code (MSB)
00H:	Device family number code (LSB)
00H:	Device family number code (MSB)
ssH:	Software revision level
ssH:	Software revision level
ssH:	Software revision level
ssH:	Software revision level
F7H:	EOX (End of Exclusive)

* Reply the message by the unique device ID when the device has received the Identity Request Message in the Broadcast.

● Data transmission

When an appropriate Data Request 1 (RQ1) message is received, the internal data will be transmitted.

○ Data set 1 DT1 (12H)

Status	Data byte	Status
F0H	41H, dev, 00H, 11H, 12H, aaH, bbH, ccH, ddH, eeH, ... ffH, sum	F7H

Byte	Explanation
F0H:	Exclusive status
41H:	ID number (Roland)
10H:	Device ID
00H:	Model ID 1 (UA-100)
11H:	Model ID 2 (UA-100)
12H:	Command (DT1)
aaH:	Address MSB: upper byte of the starting address of the data to be sent.
bbH:	Address: middle byte of the starting address of the data to be sent.
ccH:	
ddH:	Address LSB: lower byte of the starting address of the data to be sent.
eeH:	Data: the actual data to be sent. Multiple bytes of data are transmitted in order starting from the address.
:	:
ffH:	Data
sum:	Checksum
F7H:	EOX (End Of Exclusive)

* The amount of data that can be transmitted at one time depends on the type of data, and data will be transmitted from the specified starting address and size. Refer to the Address and Size given in "Individual Parameter Transmission" (p. 82).

* Data larger than 128 bytes will be divided into packets of 128 bytes or less, and each packet will be sent at an interval of about 40 ms.

* Regarding the checksum please refer to "Example of an Exclusive message and calculating a Checksum" (p. 89).

3. Individual Parameter Transmission (Model ID = 00H 11H or 42H)

Individual Parameter Transmission transmits data (or requests data) for one parameter as one Exclusive message (one packet of F0 F7).

In Individual Parameter Transmission, you must use the Address and Size listed in the following Parameter Address Map. Addresses marked at "#" cannot be used as starting addresses.

■ Address Block map

An outlined address map of the Exclusive Communication is as follows;

<Model ID = 42H>

Address (H)	Block
40 03 00	Effect Parameters

<Model ID = 00H, 11H>

Address (H)	Block
00 40 00 00	UA-100 Control
00 40 01 00	Effect Parameters
00 40 10 00	Mixer Input Control
00 40 40 00	Mixer Effect Control
00 40 50 00	Mixer Output Control
00 40 60 00	Preset Effect Control

■ Parameter Address map

This map indicates address, size, Data (range), Parameter, Description, and Default Value of parameters which can be transferred using Request data 1 (RQ1) and Data set 1 (DT1).

All the numbers of address, size, Data, and Default Value are indicated in 7-bit Hexadecimal-form. Numbers in the explanatory column are given in decimal notation.

● Effect Parameters

○ Effect parameters received with the SC-88Pro model ID (42H)

When data is received with the model ID (42H), the settings for an Insertion Effect are made.

For instance, when an insertion effect is applied to WAVE2, the data sent to 40 03 xx is set to 00 40 04 xx of Insertion Effect 4.

Address (H)	Size (H)	Data (H)	Parameter	Description	Default (H)
40 03 00	00 00 02	00 - 7F	EFX TYPE		
40 03 01#					
40 03 03	00 00 01	00 - 7F	EFX PARAMETER 1		
40 03 04	00 00 01	00 - 7F	EFX PARAMETER 2		
40 03 05	00 00 01	00 - 7F	EFX PARAMETER 3		
40 03 06	00 00 01	00 - 7F	EFX PARAMETER 4		
40 03 07	00 00 01	00 - 7F	EFX PARAMETER 5		
40 03 08	00 00 01	00 - 7F	EFX PARAMETER 6		
40 03 09	00 00 01	00 - 7F	EFX PARAMETER 7		
40 03 0A	00 00 01	00 - 7F	EFX PARAMETER 8		
40 03 0B	00 00 01	00 - 7F	EFX PARAMETER 9		
40 03 0C	00 00 01	00 - 7F	EFX PARAMETER 10		
40 03 0D	00 00 01	00 - 7F	EFX PARAMETER 11		
40 03 0E	00 00 01	00 - 7F	EFX PARAMETER 12		
40 03 0F	00 00 01	00 - 7F	EFX PARAMETER 13		

40 03 10	00 00 01	00 - 7F	EFX PARAMETER 14
40 03 11	00 00 01	00 - 7F	EFX PARAMETER 15
40 03 12	00 00 01	00 - 7F	EFX PARAMETER 16
40 03 13	00 00 01	00 - 7F	EFX PARAMETER 17
40 03 14	00 00 01	00 - 7F	EFX PARAMETER 18
40 03 15	00 00 01	00 - 7F	EFX PARAMETER 19
40 03 16	00 00 01	00 - 7F	EFX PARAMETER 20

○ Effect parameters received with model ID (00H, 11H)

When Data is received with the model ID (00H, 11H), the settings are made for the effects provided at the four input Insertion Effect positions or the settings for the effects provided at the two System Effect positions are made.

The correspondences between n and the locations where the respective effects are arranged are as shown below.

n = 1 to 6 (Effect 1 to 6)

Effect1:	Insertion Effect 1 (LINE/MIC1/MIC1+MIC2)
Effect2:	Insertion Effect 2 (MIC2)
Effect3:	Insertion Effect 3 (WAVE1)
Effect4:	Insertion Effect 4 (WAVE2)
Effect5:	System Effect 1
Effect6:	System Effect 2

<u>Address (H)</u>	<u>Size (H)</u>	<u>Data (H)</u>	<u>Parameter</u>	<u>Description</u>	<u>Default (H)</u>
00 40 0n 00	00 00 00 02	00 - 7F	EFX TYPE		
00 40 0n 01#					
00 40 0n 03	00 00 00 01	00 - 7F	EFX PARAMETER 1		
00 40 0n 04	00 00 00 01	00 - 7F	EFX PARAMETER 2		
00 40 0n 05	00 00 00 01	00 - 7F	EFX PARAMETER 3		
00 40 0n 06	00 00 00 01	00 - 7F	EFX PARAMETER 4		
00 40 0n 07	00 00 00 01	00 - 7F	EFX PARAMETER 5		
00 40 0n 08	00 00 00 01	00 - 7F	EFX PARAMETER 6		
00 40 0n 09	00 00 00 01	00 - 7F	EFX PARAMETER 7		
00 40 0n 0A	00 00 00 01	00 - 7F	EFX PARAMETER 8		
00 40 0n 0B	00 00 00 01	00 - 7F	EFX PARAMETER 9		
00 40 0n 0C	00 00 00 01	00 - 7F	EFX PARAMETER 10		
00 40 0n 0D	00 00 00 01	00 - 7F	EFX PARAMETER 11		
00 40 0n 0E	00 00 00 01	00 - 7F	EFX PARAMETER 12		
00 40 0n 0F	00 00 00 01	00 - 7F	EFX PARAMETER 13		
00 40 0n 10	00 00 00 01	00 - 7F	EFX PARAMETER 14		
00 40 0n 11	00 00 00 01	00 - 7F	EFX PARAMETER 15		
00 40 0n 12	00 00 00 01	00 - 7F	EFX PARAMETER 16		
00 40 0n 13	00 00 00 01	00 - 7F	EFX PARAMETER 17		
00 40 0n 14	00 00 00 01	00 - 7F	EFX PARAMETER 18		
00 40 0n 15	00 00 00 01	00 - 7F	EFX PARAMETER 19		
00 40 0n 16	00 00 00 01	00 - 7F	EFX PARAMETER 20		
00 40 0n 17	00 00 00 01	00 - 7F	EFX PARAMETER 21		
00 40 0n 18	00 00 00 01	00 - 7F	EFX PARAMETER 22		
00 40 0n 19	00 00 00 01	00 - 7F	EFX PARAMETER 23		
00 40 0n 1A	00 00 00 01	00 - 7F	EFX PARAMETER 24		
00 40 0n 1B	00 00 00 01	00 - 7F	EFX PARAMETER 25		
00 40 0n 1C	00 00 00 01	00 - 7F	EFX PARAMETER 26		
00 40 0n 1D	00 00 00 01	00 - 7F	EFX PARAMETER 27		
00 40 0n 1E	00 00 00 01	00 - 7F	EFX PARAMETER 28		
00 40 0n 1F	00 00 00 01	00 - 7F	EFX PARAMETER 29		
00 40 0n 20	00 00 00 01	00 - 7F	EFX PARAMETER 30		
00 40 0n 21	00 00 00 01	00 - 7F	EFX PARAMETER 31		
00 40 0n 22	00 00 00 01	00 - 7F	EFX PARAMETER 32		
00 40 0n 23	00 00 00 01	00 - 7F	EFX PARAMETER 33		
00 40 0n 24	00 00 00 01	00 - 7F	EFX PARAMETER 34		
00 40 0n 25	00 00 00 01	00 - 7F	EFX PARAMETER 35		
00 40 0n 26	00 00 00 01	00 - 7F	EFX PARAMETER 36		
00 40 0n 27	00 00 00 01	00 - 7F	EFX PARAMETER 37		
00 40 0n 28	00 00 00 01	00 - 7F	EFX PARAMETER 38		
00 40 0n 29	00 00 00 01	00 - 7F	EFX PARAMETER 39		
00 40 0n 2A	00 00 00 01	00 - 7F	EFX PARAMETER 40		

* For EFX TYPE (effect type) and EFX PARAMETER (effect parameter), refer to Section Effects.

● Mixer Parameters

○ UA-100 Control

<u>Address (H)</u>	<u>Size (H)</u>	<u>Data (H)</u>	<u>Parameter</u>	<u>Description</u>	<u>Default (H)</u>	<u>Description</u>
00 40 00 00	00 00 00 01	01-09	UA-100 MODE	1: PC Mode(VT Effect Mode) 3: PC Mode(Compact Effect Mode) 4: PC Mode(Full Effect Mode) 5: VT Mode 6: Vocal Mode 7: Guitar Mode 8: GAME Mode 9: BYPASS Mode		
* Send only (sent when the Effect Type Selector is switched or when a requested by Data Request 1)						

00 40 00 01	00 00 00 01	00 - 01	COPYRIGHT	Off/On	1	On
-------------	-------------	---------	-----------	--------	---	----

○ Mixer Input Control

<u>Address (H)</u>	<u>Size (H)</u>	<u>Data (H)</u>	<u>Parameter</u>	<u>Description</u>	<u>Default (H)</u>	<u>Description</u>
00 40 10 00	00 00 00 01	00 - 02	INPUT MODE	0: Mic Mode 1: Line Mode 2: MIC1+MIC2 Mode	0	Mic Mode
* Only when the operating mode is [PC] or [BYPASS].						
* When in the VT Effect Mode, you can't set to 2: MIC1 + MIC2 mode.						
00 40 10 01	00 00 00 01	00 - 7F	INPUT PAN1	0 - 127	40	0 (center)
00 40 10 02	00 00 00 01	00 - 7F	INPUT PAN2	0 - 127	40	0 (center)
00 40 10 03	00 00 00 01	00 - 01	MONITOR SW	Off/On	1	ON
n = 1 to 4 (n = 1: LINE/MIC1/MIC1+MIC2, n = 2: MIC2, n = 3: WAVE1, n = 4: WAVE2)						
00 40 1n 00	00 00 00 01	00 - 7F	SEND1 LEVEL	0 - 127	64	100
* Only when the operating mode is [PC] and in the Full/Compact Effect Mode.						
00 40 1n 02	00 00 00 01	00 - 7F	SEND2 LEVEL	0 - 127	64	100
* Only when the operating mode is [PC] and in the Full/Compact Effect Mode.						
00 40 1n 04	00 00 00 01	00 - 7F	SUB LEVEL	0 - 127	64	100
* Not valid when in the [VT] mode or the [PC] mode (VT Effect Mode).						
00 40 1n 05	00 00 00 01	00 - 7F	FADER LEVEL	0 - 127	64	100
00 40 1n 06	00 00 00 01	00 - 01	MUTE SW	Off/On	0	OFF
* Only when the operating mode is [PC] (Full/Compact Effect mode) or [BYPASS].						
00 40 1n 07	00 00 00 01	00 - 01	SOLO SW	Off/On	0	OFF
* Only when the operating mode is [PC] (Full/Compact Effect Mode) or [BYPASS].						

○ Mixer Effect Control

* The addresses shown below can be accessed only when the operating mode is [PC].

Address (H)	Size (H)	Data (H)	Parameter	Description	Default (H)	Description
00 40 40 00	00 00 00 01	01-04	EFFECT MODE	01:VT Effect Mode 03: Compact Effect Mode(1 Insertion effect + 2 System effects) 04: Full Effect Mode(1 effect)		
	* Receive only					
00 40 40 01	00 00 00 01	00 - 01	IEFX1 SW	Off/On	0	OFF
00 40 40 02	00 00 00 01	00 - 01	IEFX2 SW	Off/On	0	OFF
00 40 40 03	00 00 00 01	00 - 01	IEFX3 SW	Off/On	0	OFF
00 40 40 04	00 00 00 01	00 - 01	IEFX4 SW	Off/On	0	OFF
00 40 40 05	00 00 00 01	00 - 01	SYSEFX1 SW	Off/On	0	OFF
00 40 40 06	00 00 00 01	00 - 01	SYSEFX2 SW	Off/On	0	OFF
	* When EFFECT MODE is 01: VT Effect mode, only one of the IEFX1 through 4 switches is on. Also, the SYSEFX1 and 2 switches cannot be switched on.					
	* When EFFECT MODE is 03: Compact Effect mode, only one of the IEFX1 through 4 switches is on.					
	* When EFFECT MODE is 04: Full Effect mode, only one of the IEFX1 through 4 or SYSEFX1 and 2 switches is on.					
	* The SYSEFX1/2 SW are deactivated when in the [PC] mode (VT Effect mode).					
00 40 40 07	00 00 00 01	00 - 7F	RET1 MASTER	0 - 127	64	100
00 40 40 08	00 00 00 01	00 - 7F	RET1 SUB	0 - 127	64	100
00 40 40 09	00 00 00 01	00 - 7F	RET2 MASTER	0 - 127	64	100
00 40 40 0A	00 00 00 01	00 - 7F	RET2 SUB	0 - 127	64	100
	* RET1/2 and MASTER and RET1/2 and SUB are deactivated when in the [PC] mode (VT Effect mode).					
00 40 40 0B	00 00 00 01	00 - 0F	VO1 RECEIVECH	0 - 15	0	1ch
	* Only when in the VT Effect mode					
00 40 40 0C	00 00 00 01	00 - 01	VO1 NOTE SW	Off/On	1	On
	* Only when in the VT Effect mode					
00 40 40 0D	00 00 00 01	00 - 01	VO1 BEND SW	Off/On	1	On
	* Only when in the VT Effect mode					
00 40 40 0E	00 00 00 01	00 - 0F	VO2 RECEIVECH	0 - 15	0	2ch
	* Only when in the VT Effect mode					
00 40 40 0F	00 00 00 01	00 - 01	VO2 NOTE SW	Off/On	1	On
	* Only when in the VT Effect mode					
00 40 40 10	00 00 00 01	00 - 01	VO2 BEND SW	Off/On	1	On
	* Only when in the VT Effect mode					

○ Preset Effect Control

* The addresses shown below can be accessed only when the operating mode is [VT], [VOCAL], [GUITAR], or [GAME].

<u>Address (H)</u>	<u>Size (H)</u>	<u>Data (H)</u>	<u>Parameter</u>	<u>Description</u>	<u>Default (H)</u>	<u>Description</u>
n = 0 to 3 (0: Voice Transformer, 1: Vocal, 2: Guitar, 3: GAME)						
00 40 6n 00	00 00 00 01	00 - 27	PARAM NUMBER1	0 - 39	0	0
00 40 6n 01	00 00 00 01	00 - 27	PARAM NUMBER2	0 - 39	0	0
00 40 6n 02	00 00 00 01	00 - 27	PARAM NUMBER3	0 - 39	0	0
00 40 6n 03	00 00 00 01	00 - 27	PARAM NUMBER4	0 - 39	0	0
00 40 6n 04	00 00 00 01	00 - 7F	DEFAULT VALUE1	0 - 127		
00 40 6n 05	00 00 00 01	00 - 7F	DEFAULT VALUE2	0 - 127		
00 40 6n 06	00 00 00 01	00 - 7F	DEFAULT VALUE3	0 - 127		
00 40 6n 07	00 00 00 01	00 - 7F	DEFAULT VALUE4	0 - 127		
00 40 6n 08	00 00 00 01	00 - 7F	DEFAULT VALUE5	0 - 127		
00 40 6n 09	00 00 00 01	00 - 7F	DEFAULT VALUE6	0 - 127		
00 40 6n 0A	00 00 00 01	00 - 7F	DEFAULT VALUE7	0 - 127		
00 40 6n 0B	00 00 00 01	00 - 7F	DEFAULT VALUE8	0 - 127		
00 40 6n 0C	00 00 00 01	00 - 7F	DEFAULT VALUE9	0 - 127		
00 40 6n 0D	00 00 00 01	00 - 7F	DEFAULT VALUE10	0 - 127		
00 40 6n 0E	00 00 00 01	00 - 7F	DEFAULT VALUE11	0 - 127		
00 40 6n 0F	00 00 00 01	00 - 7F	DEFAULT VALUE12	0 - 127		
00 40 6n 10	00 00 00 01	00 - 7F	DEFAULT VALUE13	0 - 127		
00 40 6n 11	00 00 00 01	00 - 7F	DEFAULT VALUE14	0 - 127		
00 40 6n 12	00 00 00 01	00 - 7F	DEFAULT VALUE15	0 - 127		
00 40 6n 13	00 00 00 01	00 - 7F	DEFAULT VALUE16	0 - 127		
00 40 6n 14	00 00 00 01	00 - 7F	DEFAULT VALUE17	0 - 127		
00 40 6n 15	00 00 00 01	00 - 7F	DEFAULT VALUE18	0 - 127		
00 40 6n 16	00 00 00 01	00 - 7F	DEFAULT VALUE19	0 - 127		
00 40 6n 17	00 00 00 01	00 - 7F	DEFAULT VALUE20	0 - 127		
00 40 6n 18	00 00 00 01	00 - 7F	DEFAULT VALUE21	0 - 127		
00 40 6n 19	00 00 00 01	00 - 7F	DEFAULT VALUE22	0 - 127		
00 40 6n 1A	00 00 00 01	00 - 7F	DEFAULT VALUE23	0 - 127		
00 40 6n 1B	00 00 00 01	00 - 7F	DEFAULT VALUE24	0 - 127		
00 40 6n 1C	00 00 00 01	00 - 7F	DEFAULT VALUE25	0 - 127		
00 40 6n 1D	00 00 00 01	00 - 7F	DEFAULT VALUE26	0 - 127		
00 40 6n 1E	00 00 00 01	00 - 7F	DEFAULT VALUE27	0 - 127		
00 40 6n 1F	00 00 00 01	00 - 7F	DEFAULT VALUE28	0 - 127		
00 40 6n 20	00 00 00 01	00 - 7F	DEFAULT VALUE29	0 - 127		
00 40 6n 21	00 00 00 01	00 - 7F	DEFAULT VALUE30	0 - 127		
00 40 6n 22	00 00 00 01	00 - 7F	DEFAULT VALUE31	0 - 127		
00 40 6n 23	00 00 00 01	00 - 7F	DEFAULT VALUE32	0 - 127		
00 40 6n 24	00 00 00 01	00 - 7F	DEFAULT VALUE33	0 - 127		
00 40 6n 25	00 00 00 01	00 - 7F	DEFAULT VALUE34	0 - 127		
00 40 6n 26	00 00 00 01	00 - 7F	DEFAULT VALUE35	0 - 127		
00 40 6n 27	00 00 00 01	00 - 7F	DEFAULT VALUE36	0 - 127		
00 40 6n 28	00 00 00 01	00 - 7F	DEFAULT VALUE37	0 - 127		
00 40 6n 29	00 00 00 01	00 - 7F	DEFAULT VALUE38	0 - 127		
00 40 6n 2A	00 00 00 01	00 - 7F	DEFAULT VALUE39	0 - 127		
00 40 6n 2B	00 00 00 01	00 - 7F	DEFAULT VALUE40	0 - 127		
00 40 60 7F	00 00 00 01	0	PARAM WRITE			
	* Receive only					

4. Supplementary Material

■ Decimal and Hexadecimal table

In MIDI documentation, data values and addresses/sizes of Exclusive messages etc. are expressed as hexadecimal values for each 7 bits. The following table shows how these correspond to decimal numbers.

Decimal and Hexadecimal table (An "H" is appended to the end of numbers in hexadecimal notation.)

Dec.	Hex.	Dec.	Hex.	Dec.	Hex.	Dec.	Hex.
0	00H	32	20H	64	40H	96	60H
1	01H	33	21H	65	41H	97	61H
2	02H	34	22H	66	42H	98	62H
3	03H	35	23H	67	43H	99	63H
4	04H	36	24H	68	44H	100	64H
5	05H	37	25H	69	45H	101	65H
6	06H	38	26H	70	46H	102	66H
7	07H	39	27H	71	47H	103	67H
8	08H	40	28H	72	48H	104	68H
9	09H	41	29H	73	49H	105	69H
10	0AH	42	2AH	74	4AH	106	6AH
11	0BH	43	2BH	75	4BH	107	6BH
12	0CH	44	2CH	76	4CH	108	6CH
13	0DH	45	2DH	77	4DH	109	6DH
14	0EH	46	2EH	78	4EH	110	6EH
15	0FH	47	2FH	79	4FH	111	6FH
16	10H	48	30H	80	50H	112	70H
17	11H	49	31H	81	51H	113	71H
18	12H	50	32H	82	52H	114	72H
19	13H	51	33H	83	53H	115	73H
20	14H	52	34H	84	54H	116	74H
21	15H	53	35H	85	55H	117	75H
22	16H	54	36H	86	56H	118	76H
23	17H	55	37H	87	57H	119	77H
24	18H	56	38H	88	58H	120	78H
25	19H	57	39H	89	59H	121	79H
26	1AH	58	3AH	90	5AH	122	7AH
27	1BH	59	3BH	91	5BH	123	7BH
28	1CH	60	3CH	92	5CH	124	7CH
29	1DH	61	3DH	93	5DH	125	7DH
30	1EH	62	3EH	94	5EH	126	7EH
31	1FH	63	3FH	95	5FH	127	7FH

* Decimal values such as MIDI channel, Bank Select, and Program Change are listed as one greater than the values given in the above table.

* 7-bit byte can express data in the range of 128 steps. For data where greater precision is required, we must use two or more bytes.
For example, two hexadecimal numbers aa bbH expressing two 7-bit bytes would indicate a value of $aa \times 128 + bb$.

* In the case of values which have a +/- sign, 00H = -64, 40H = +/-0, and 7FH = +63, so that the decimal expression would be 64 less than the value given in the above chart.

In the case of two types, 00 00H = -8192, 40 00H = +/-0, and 7F 7FH = +8191. For example if aa bbH were expressed as decimal, this would be $aa \text{ bbH} - 40 \text{ 00H} = aa \times 128 + bb - 64 \times 128$.

<Example 1> What is the decimal expression of 5AH?
From the preceding table, 5AH = 90

<Example 2> What is the decimal expression of the value 12 34H given as hexadecimal for each 7 bits?

From the preceding table, since 12H = 18 and 34H = 52
 $18 \times 128 + 52 = 2356$

● Examples of actual MIDI messages

<Example 1> E1 00 28

EnH is the Pitch Bend Change status, and n is the MIDI channel number. The 2nd byte (00H = 0) is the LSB and the 3rd byte (28H = 40) is the MSB, but Pitch Bend value is a signed number in which 40 00H (= $64 \times 12 + 80 = 8192$) is 0, so this Pitch Bend value is

$$28 \text{ 00H} - 40 \text{ 00H} = 40 \times 12 + 80 - (64 \times 12 + 80) = 5120 - 8192 = -3072$$

If the Pitch Bend Sensitivity is set to 2 semitones, -8192 (00 00H) will cause the pitch to change -200 cents, so in this case $-200 \times (-3072) / (-8192) = -75$ cents of Pitch Bend is being applied to MIDI channel 2.

<Example 2> B1 64 00 65 00 06 0C 26 00 64 7F 65 7F

BnH is the Control Change status, and n is the MIDI channel number. For Control Changes, the 2nd byte is the Controller number, and the 3rd byte is the value. In a case in which two or more messages consecutive messages have the same status, MIDI has a provision called running status which allows the status byte of the second and following messages to be omitted. Thus, the above messages have the following meaning.

B1	64 00	MIDI ch.2, lower byte of RPN parameter number:	00H
(B1)	65 00	(MIDI ch.2) upper byte of RPN parameter number:	00H
(B1)	06 0C	(MIDI ch.2) upper byte of parameter value:	0CH
(B1)	26 00	(MIDI ch.2) lower byte of parameter value:	00H
(B1)	64 7F	(MIDI ch.2) lower byte of RPN parameter number:	7FH
(B1)	65 7F	(MIDI ch.2) upper byte of RPN parameter number:	7FH

In other words, the above messages specify a value of 0C 00H for RPN parameter number 00 00H on MIDI channel 2, and then set the RPN parameter number to 7F 7FH.

RPN parameter number 00 00H is Pitch Bend Sensitivity, and the MSB of the value indicates semitone units, so a value of 0CH = 12 sets the maximum Pitch Bend range to +/-12 semitones (1 octave). (On UA-100 the LSB of Pitch Bend Sensitivity is ignored, but the LSB should be transmitted anyway (with a value of 0) so that operation will be correct on any device.)

Once the parameter number has been specified for RPN, all Data Entry messages transmitted on that same channel will be valid, so after the desired value has been transmitted, it is a good idea to set the parameter number to 7F 7FH to prevent accidents. This is the reason for the (B3) 64 7F (B3) 65 7F at the end.

It is not desirable for performance data (such as Standard MIDI File data) to contain many events with running status as given in <Example 2>. This is because if playback is halted during the song and then rewound or fast-forwarded, the sequencer may not be able to transmit the correct status, and the sound source will then misinterpret the data. Take care to give each event its own status.

It is also necessary that the RPN parameter number setting and the value setting be done in the proper order. On some sequencer software, events occurring in the same (or consecutive) clock may be transmitted in an order different than the order in which they were received. For this reason it is a good idea to slightly skew the time of each event (about 1 tick for TPQN = 96, and about 5 ticks for TPQN = 480).

* TPQN: Ticks Per Quarter Note

■ Example of an Exclusive message and calculating a Checksum

Roland Exclusive messages (RQ1,DT1) are transmitted with a checksum at the end (before F7) to make sure that the message was correctly received. The value of the checksum is determined by the address and data (or size) of the transmitted Exclusive message.

● How to calculate the checksum (hexadecimal numbers are indicated by "H")

The checksum is a value derived by adding the address, size and checksum itself and inverting the lower 7 bits.

Here's an example of how the checksum is calculated. We will assume that in the Exclusive message we are transmitting, the address is aa bb cc ddH and the data or size is ee ff gg hhH.

$$\begin{aligned} aa + bb + cc + dd + ee + ff + gg + hh &= \text{sum} \\ \text{sum} / 128 &= \text{quotient... remainder} \\ 128 - \text{remainder} &= \text{checksum} \end{aligned}$$

<Example 1> Setting EFX TYPE for insertion effect 3 to Guitar Multi1

According to the Parameter Address Map, the address of the EFX TYPE for insertion effect 3 is 00 40 03 30H, and the setting data for Guitar Multi1 is [04H, 00H]. Thus,

F0	41	10	00 11	12	00 40 03 00	04 00	??	F7
(1)	(2)	(3)	(4)	(5)	address	data	checksum	(6)

(1) Exclusive status,	(2) ID (Roland),	(3) Device ID (17),
(4) Model ID (UA-100),	(5) Command ID (DT1),	(6) End of Exclusive

Next we calculate the checksum.

$$\begin{aligned} 00H + 40H + 03H + 00H + 04H + 00H &= 0 + 64 + 3 + 0 + 4 + 0 = 71 \text{ (sum)} \\ 71 \text{ (sum)} / 128 &= 0 \text{ (quotient)... } 71 \text{ (remainder)} \\ \text{checksum} &= 128 - 71 \text{ (remainder)} = 57 = 39H \end{aligned}$$

This means that F0 41 10 00 11 12 00 40 03 00 04 00 39 F7 is the message we transmit.

<Example 2> Requesting sending of UA-100 MODE (operating mode)

According to the Parameter Address Map, the address of the UA-100 MODE is 00 40 00 00H, and the size is 00 00 00 01H. Thus,

F0	41	0	00 11	11	00 40 00 00	00 00 00 01	??	F7
(1)	(2)	(3)	(4)	(5)	address	data	checksum	(6)

(1) Exclusive status,	(2) ID (Roland),	(3) Device ID (17),
(4) Model ID (UA-100),	(5) Command ID (RQ1),	(6) End of Exclusive

Next we calculate the checksum.

$$\begin{aligned} 00H + 40H + 00H + 00H + 00H + 00H + 00H + 01H &= 0 + 64 + 0 + 0 + 0 + 0 + 0 + 1 = 65 \text{ (sum)} \\ 65 \text{ (sum)} / 128 &= 0 \text{ (quotient) ... } 65 \text{ (remainder)} \\ \text{checksum} &= 128 - 65 \text{ (remainder)} = 63 = 3FH \end{aligned}$$

This means that F0 41 10 00 11 11 00 40 00 00 00 00 01 3F F7 is the message we transmit.

MIDI Implementation Chart

AUDIO & MIDI
PROCESSING UNIT
Model UA-100G

MIDI Implementation Chart

Date: '99.9

Version: 1.00

	Function...	Transmitted	Recognized	Remarks
Basic	Default	x	1-16	Valid at VT Effect mode
Channel	Changed	x	1-16	
Mode	Default	x	x	---
	Message	x	x	
	Altered	*****	---	
Note	---	x	0-127	Valid at VT Effect mode
Number	: True Voice	*****	0-127	
Velocity	NOTE ON	x	x	---
	NOTE OFF	x	x	
Aftertouch	Key's	x	x	---
	Ch's	x	x	
Pitch Bend	---	x	o *1	---
Control	6,38	x	o	Data Entry
Change	7	x	o	Main Fader
	10	x	o	Panpot
	16	x	o	Send 1
	17	x	o	Send 2
	18	x	o	Mute
	19	x	o	Solo
	20	x	o	Sub Fader
	21	x	o	MIC/LINE Selector
	22	x	o	Output Selector
	23	x	o	Effect Switch
	100,101	x	o	RPN LSB,MSB
Program	---	x	x	---
Change	: True #	*****	---	
System Exclusive		o	o	---
System	: Song Pos.	x	x	---
Common	: Song Sel.	x	x	
	: Tune	x	x	
System	: Clock	x	x	---
Real Time	: Commands	x	x	
Aux	: All Sounds OFF	o	x	---
Messages	: Reset All Controllers	o	x	
	: Local ON/OFF	x	x	
	: All Notes OFF	o	x	
	: Active Sensing	o	o	
	: Reset	x	x	
Notes		*1 o x is selectable.		

Mode 1: OMNI ON, POLY
Mode 3: OMNI OFF, POLY

Mode 2: OMNI ON, MONO
Mode 4: OMNI OFF, MONO

o: Yes
x: No

Troubleshooting

If an unexpected problem occurs while you are using the UA-100, first refer to this chapter and to the "**Troubleshooting**" chapter of the Getting Started. You will find numerous hints for solving various problems.

First check whether a solution is provided in the Getting Started or in the Troubleshooting section of this manual.

Troubleshooting

If you are using Windows for the first time, or do not understand the explanation of a procedure, refer to the owner's manual that came with your computer or Windows. Check "**Troubleshooting**" in the Getting Started, and the following items in this manual. If the UA-100 still does not operate as you expect, access the web site for Edirol Corporation North America. There you'll find up-to-date information for troubleshooting.

The web site for Edirol Corporation North America

<http://www.edirol.com/>

Points to Check on the UA-100

For problems such as "**Power does not turn on**" or "**No sound**", refer to the "**Troubleshooting**" chapter of the Getting Started.

■ Sound Is Distorted

Is an Effect Being Applied?

Use the following procedure to check.

1. Either set the UA-100's **Effect Type Selector** to[BYPASS], or open the **Mixer** window in the **UA-100 Controller**, and turn off all effects (Compact Effect/Full Effect/System Effect) so that no effects are being applied.
2. If audio is being input from the **Line Input Jacks**, use the UA-100's **Line Input Volume** to decrease the input level.
3. If audio is being input from the **MIC1/GUITAR Input Jack**, use the UA-100's **MIC1/GUITAR Input Volume** to decrease the input level.
4. One at a time, turn on the effects that you turned off in **step 1**.
5. At this time, notice whether the Input Level Peak Indicator lights red. If it lights red, return to **step 2** and adjust the input level.
6. If the sound is still distorted, use the **Main fader**, the **MASTER fader** or the Windows **Volume Control** to adjust the output level.

MEMO

For details on using the mixer of the UA-100 Controller, refer to UA-100 Controller Help.

MEMO

If you are using effects such as **Flanger** or **Phaser** which have **resonance** or **feedback** parameters, you will especially need to adjust the input level as described here.

Is the Peak Level Indicator Lit Red?

If audio is being input from the **Line Input Jack**, use the UA-100's **Line Input Volume** to reduce the input level. If audio is being input from the **MIC1/GUITAR Input Jack**, use the UA-100's **MIC1/GUITAR Input Volume** to reduce the input level.

Is the Volume Setting Appropriate?

Refer to "**Adjusting the Output Level**" (p. 41).

Are You Using a Game or Wave Data Playback Software?

If the sound is distorted when playing back Wave data from your computer (such as when using a game or Wave data playback software), use the Main fader in the **Mixer** window of the **UA-100 Controller**, the **MASTER fader**, or the **Windows Volume Control** to adjust the output level.

■ Noise Occurs During Audio Playback.

Has a Microphone Been Left Connected?

If a microphone is connected to the UA-100, rotate the **MIC1/GUITAR Input Volume** or **MIC2 Input Volume** all the way to the left to turn down the input level.

In Some Cases, the Graphics Accelerator May Cause Noise to Be Present in the Audio Playback.

Use the following procedure to set graphics acceleration to None.

1. In the Windows **Control Panel**, double-click **Display** to open the **Display Properties** dialog box, and click the **Settings** tab.

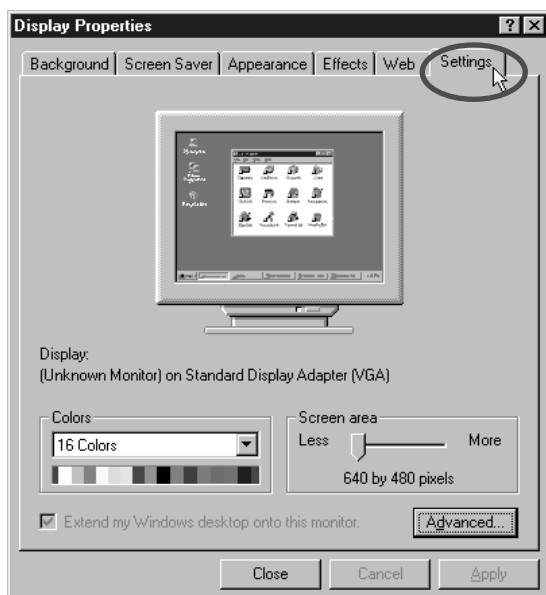

2. Click **[Advanced]**, and in the property window that appears, click the **Performance** tab.

3. In the **Graphics** section, set the Hardware acceleration slider to None, and then click **[OK]**.

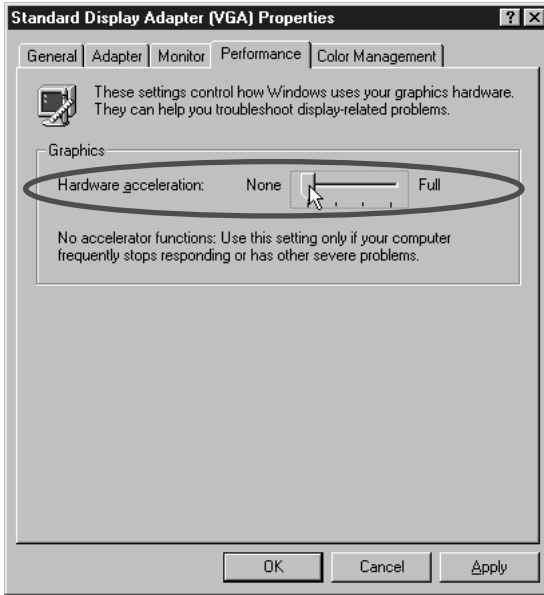

4. In the **Display Properties** dialog box, click **[OK]** to close the dialog box. Then restart your computer.

Noise May Appear in the Line Input or the Mic Input.

Depending on your computer system, noise generated by the computer or display may be heard in the line input.

If this occurs, you can apply the Noise Suppressor insertion effect in Compact Effect mode to the line input to minimize the noise.

■ Sound is Interrupted During Audio Playback.

Increase the Size of the Buffer

1. Double-click **Multimedia** in the Windows **Control Panel** to open the **Multimedia Properties** dialog box, then click the **Devices** tab.

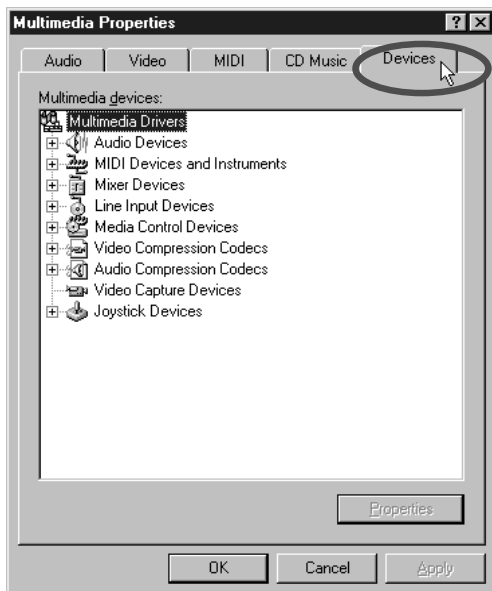

2. Double-click the **Audio Devices** and double-click **Audio for Roland UA-100 Wave** in the list that is opened to display the **Audio for Roland UA-100 Wave Properties** dialog box.
3. Click **Settings** in the dialog box to call up the **Roland UA-100 USB Driver Settings** dialog box.

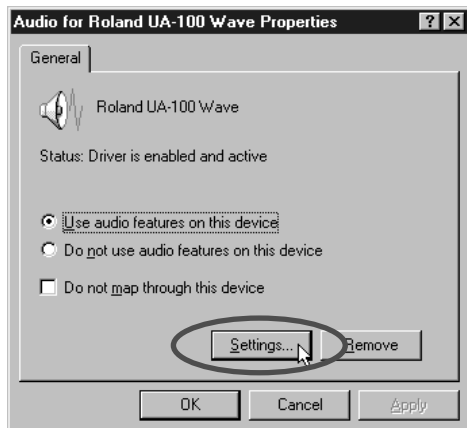

4. Set the **Audio Buffer Size** slider to **Max**, and click **[OK]**.

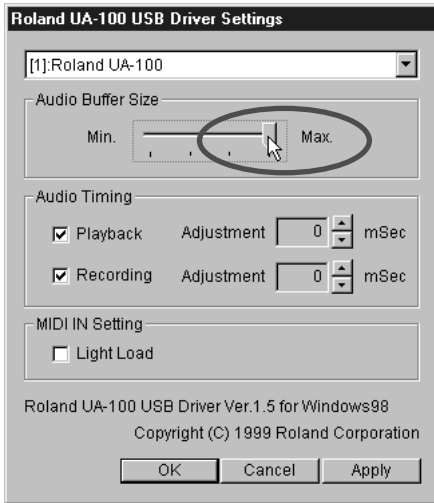

Install More Memory

By installing more memory you can increase the processing power of your computer. For details on installing memory, refer to the owner's manual for your computer.

Are a Large Number of Applications Running?

If there is insufficient memory, it may not be possible to start up another application. Exit any unneeded applications before you start up a new application. If an application remains in the **task bar** even after you have closed its window, it is still running. You will need to exit all unneeded applications that appear in the **task bar**. If an error message is still displayed, try restarting Windows.

Modify the Disk Drive Settings as Follows

1. In the Windows **Control Panel**, double-click **System**.
2. Click the **Device Manager** tab.
3. Double-click **Disk drives** to access the list of devices.
4. From the list, select **GENERIC IDE DISK TYPE01**, and click Properties to access the **GENERIC IDE DISK TYPE01** Properties dialog box.

* In **GENERIC IDE DISK TYPE01**, the number **01** may differ depending on your computer system.

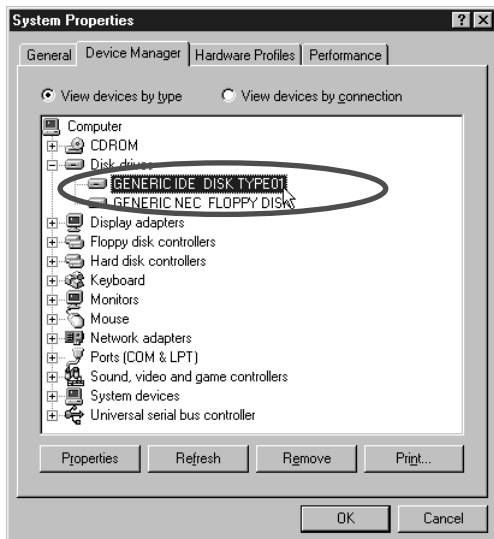

5. Click the **Settings** tab, check the **DMA** check box in Options, and click **[OK]**.

* Depending on your system, a dialog box for DMA settings may appear. Verify the contents of the dialog box, and click **[OK]** or **[Cancel]**.

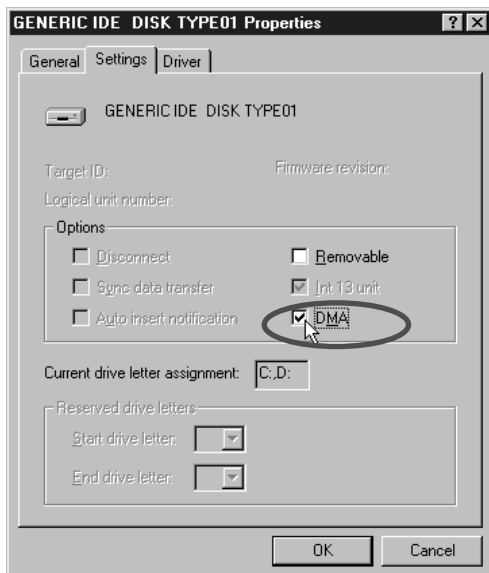

6. In **System Properties** dialog box, click **[OK]** to close the dialog box. Restart your computer to make these settings take effect.

■ Audio Playback Stops

On some models of computer, the Power Management settings in the Control Panel may cause the audio playback to stop. The content of Power Supply Properties that appears when you double-click Power Management will differ depending on your computer system. One example is given below, but you will need to refer to the owner's manual for your computer to verify the situation for your computer. Some computers may not have the following setting items.

(Example:)

1. In the Windows **Control Panel**, double-click **System**. The **System Properties** dialog box will appear.
2. Click the **Device Manager** tab. Double-click **System devices** to display the list of devices.

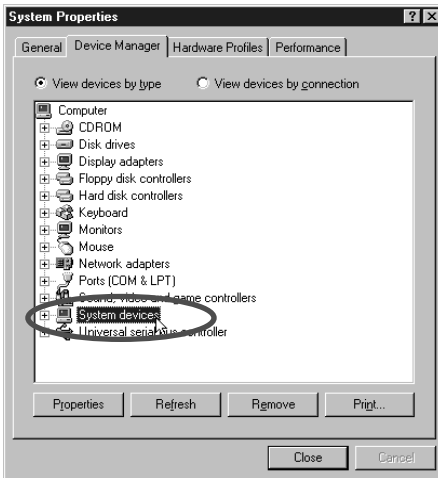

3. From the list, select **Advanced Power Management support**, and click **[Properties]** to access the **Advanced Power Management support Properties** dialog box.
4. Click the **Settings** tab, check the **Disable power status polling** check box in the Troubleshooting section, and click **[OK]**.

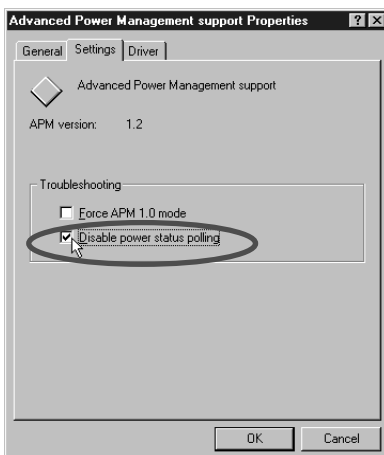

5. In **System Properties** dialog box, click **[OK]**.
6. Re-start Windows.



On some models of computer, the audio playback may stop for a moment when the screen saver switches in.

■ MIDI Playback is Unstable.

■ The Tempo Becomes Considerably Irregular During MIDI Playback or Recording.

■ Screen Operation is Jerky During a Game or the Like with MIDI Background Music.

■ MIDI and Audio Are Not Synchronized.

Decrease the Size of the Audio Buffer

1. Double-click **Multimedia** in the Windows **Control Panel** to open the **Multimedia Properties** dialog box, then click the **Devices** tab.

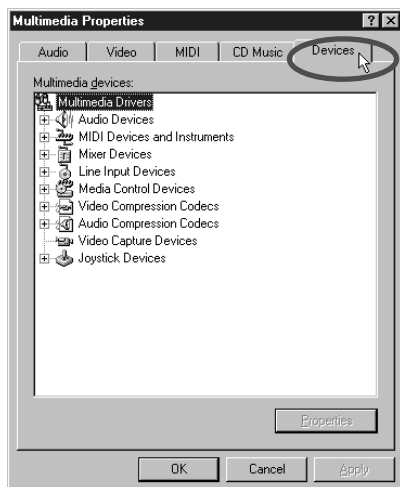

2. Double-click the **Audio Devices** and double-click **Audio for Roland UA-100 Wave** in the list that is opened to display the **Audio for Roland UA-100 Wave Properties** dialog box.

3. Click **[Settings]** in the dialog box to call up the **Roland UA-100 USB Driver Settings** dialog box.

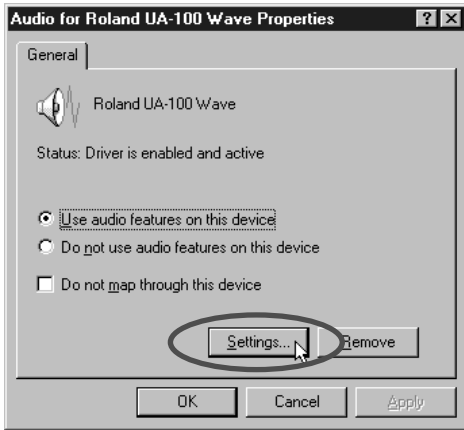

4. Set the **Audio Buffer Size** slider to **Min**, and click **[OK]**.

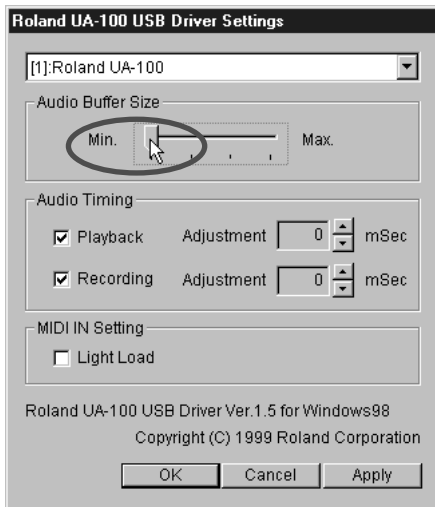

Change the Setting of the MIDI Option

If PC configuration-related problems like those described below occur, selecting this check box may improve the situation in some cases.

1. Double-click **Multimedia** in the Windows **Control Panel** to open the **Multimedia Properties** dialog box, then click the **Devices** tab.

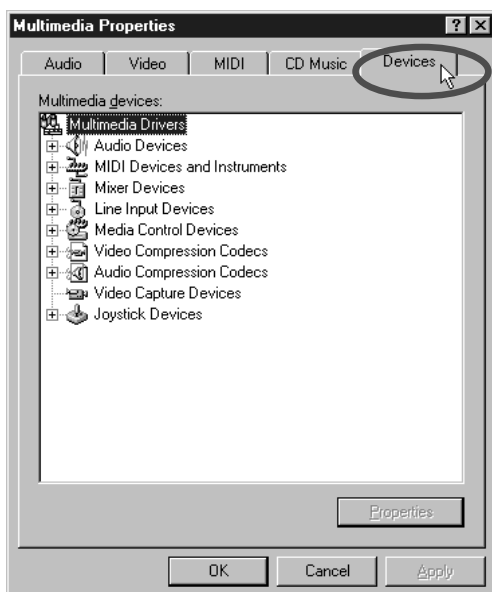

2. Double-click the **Audio Devices** and double-click **Audio for Roland UA-100 Wave** in the list that is opened to display the **Roland UA-100 USB Driver Settings** dialog box.
3. Click **Settings** in the dialog box to call up the **Roland UA-100 USB Driver Settings** dialog box.



NOTE

Windows must be restarted in order to have any changes in this setting take effect. Use the default setting (no check mark) if none of the problems described above is present.

4. In **MIDI IN Setting**, check **Light Load** and click **[OK]**.

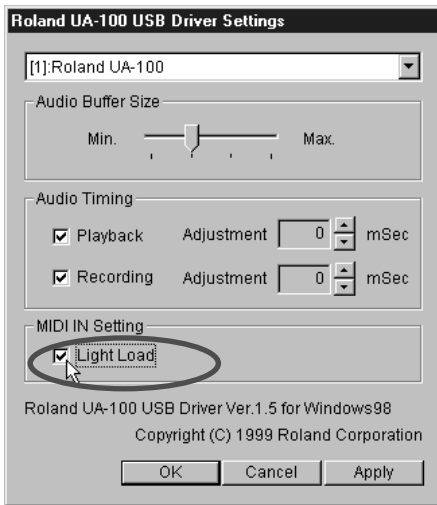

■ Background Music for a Game Does Not Sound

Is the Background Music for the Game on an Audio CD?

If the game uses an audio CD to play music, connect the Line Input Jack of the UA-100 to your computer's Line Out jacks (the jacks which output the CD sound). Make sure that the Line Input Volume is set to an appropriate level (volume).

■ Screen Movements Are Unstable When Playing a Game.

■ Screen Movements and Sound Are Not Synchronized in a Game.

Decrease the Size of the Buffer

1. Double-click **Multimedia** in the Windows **Control Panel** to open the **Multimedia Properties** dialog box, then click the **Devices** tab.

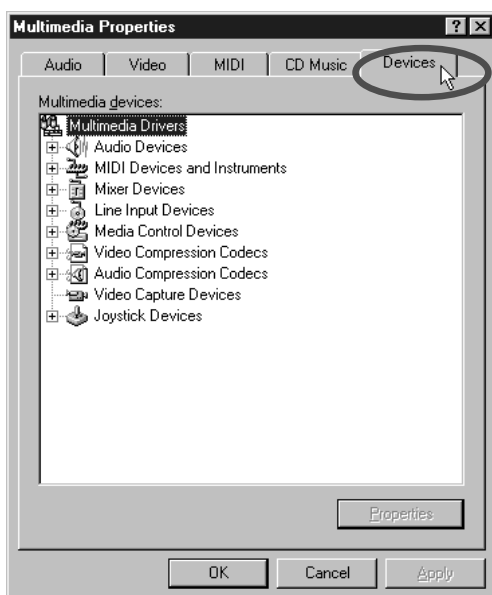

2. Double-click the **Audio Devices** and double-click **Audio for Roland UA-100 Wave** in the list that is opened to display the **Audio for Roland UA-100 Wave Properties** dialog box.

3. Click **Settings** in the dialog box to call up the **Roland UA-100 USB Driver Settings** dialog box.



4. Set the **Audio Buffer Size** slider to **Min**, and click [OK].

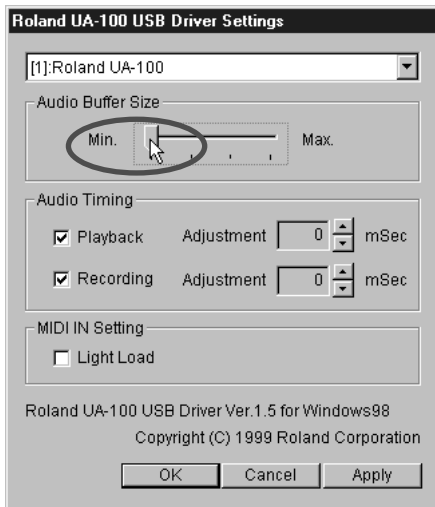

Points to Check for the UA-100 Driver

■ Search for Unknown Device Is Not Performed Automatically.

■ Search for Unknown Device Ends Before Completion.

Is the USB Cable Connected Correctly?

Make sure that the UA-100 and your computer are connected correctly via the USB cable.

Is the Power of the UA-100 Turned On?

Make sure that the power indicator of the UA-100 is lit. If it is not lit, press the power switch to turn on the power.

Is the USB Enabled for Use on Your Computer?

Refer to the owner's manual for your computer, and make sure that the USB is enabled for use.

Are "Other devices" Displayed in the List of Devices?

Use the following procedure to delete Unsupported Devices, Unknown Devices and USB Composite Devices from Other devices, and then restart your computer.

1. In the Windows **Control Panel**, double-click **System**. The **System Properties** dialog box will appear.
2. Click the **Device Manager** tab.
3. Double-click **Other devices** to display the list of devices.
4. If there are **Unknown Device** in the list, selected them and click **[Remove]**.
5. **Confirm Device Removal** dialog box, click **[OK]**.
6. Make sure that Other Device and Unknown Device are not displayed in the list, and click **[Close]** to close the dialog box.

■ Unknown Device Search Dialog Box Appears Even Though.

If your computer or your USB hub has two or more USB connectors, connecting the UA-100 to a USB connector to which a UA-100 has never been connected may cause the **Unknown device** dialog box to appear, even if the UA-100 driver has already been installed in the computer. This dialog box will automatically close after the UA-100 driver has been loaded, and subsequent operation will be normal. This is not a malfunction.

■ The UA-100 Driver Is Not Installed Correctly.

Follow the steps for “**Deleting the UA-100 Driver**” in the Getting Started to delete the UA-100 driver from the computer, then refer to “**Connections and Installation of the Driver**” in the Getting Started to install the UA-100 driver again.

Points to Check for the UA-100 Controller

■ Does Not Start Up

Is the UA-100 Driver Installed?

In order to use the UA-100 Controller to operate the UA-100, the UA-100 Driver must be installed. For the installation procedure, refer to “Connections and Installation of the Driver” in the Getting Started.

Is the Power of the UA-100 Turned On?

The UA-100 Controller cannot be used if the power of the UA-100 is not turned on. Refer to “Connections and Installation of the Driver” in the Getting Started, and make sure that connections have been made correctly. Turn on the power of the UA-100.

■ Can't Record Audio.

Has the Input Mode Appropriate for the Input Source Been Selected?

If you are recording from **Line Input**, set the **Mic/Guitar Select Button** of the **Mixer** or **VT Mixer** window of the **UA-100 controller** to the **Line** position to select **Line Input**. Similarly, if you are recording from **Mic Input**, set the **Mic/Guitar Select Button** to the **Mic/Guitar** or **Mic1+Mic2** position. For details refer to “Using the UA-100” (p. 19) and UA-100 Controller Help.

Are the Faders Raised?

In the **Mixer** or **VT Mixer** window of the **UA-100 controller**, raise the level of the **Main Fader** or **Wave Output Fader** to increase the volume of the signal that you are recording. For details refer to “Using the UA-100” (p. 19) and UA-100 Controller Help.

Has the Wave Source Selector Been Set Correctly?

In the **Mixer** or **VT Mixer** function of the **UA-100 Controller**, set the **Wave Source Selector** to the source that you wish to record. For details refer to “Using the UA-100” (p. 19) and UA-100 Controller Help.

Index

A

AC Adapter Jack	10
Audio Block	12

B

BYPASS mode	9
-------------------	---

C

Changing the default values of the effects	18
Copyright protection mode	60

D

Digital Output Connector	10
--------------------------------	----

E

EASY SETTING	15
Effect Controller 1/2, 3/4	7
effect select button	15–16
Effect Type Selector	7–8

G

GAME mode	9
GUITAR mode	8

H

Headphone Jack	7
----------------------	---

I

Input Level/Peak Indicator	6
----------------------------------	---

L

Line Input Jacks	10
Line Input Volume	10
Line Output Jacks	10
Line Output Volume	7

M

Mic 1/ Guitar Input Jack	6
Mic 1/Guitar Function Indicator	6
Mic 1/Guitar Input Volume	6
Mic 2 Input Jack	6
Mic 2 Input Volume Knob	6
MIDI IN 1/2 Connectors	10
MIDI Interface Block	13
MIDI OUT 1/2 Connectors	10

O

Output Level Indicators	7
-------------------------------	---

P

PC mode	8
Power Indicator	7
Power Switch	7

U

UA-100 Controller	14
Control Assign window	17
Effect Assign window	18
Effects window	16
Main window	14
Mixer window	15
VT Mixer window	16
USB Connector	10

V

VOCAL mode	8
VT mode	8

